

Installation manual
(Translation of original language)

EN

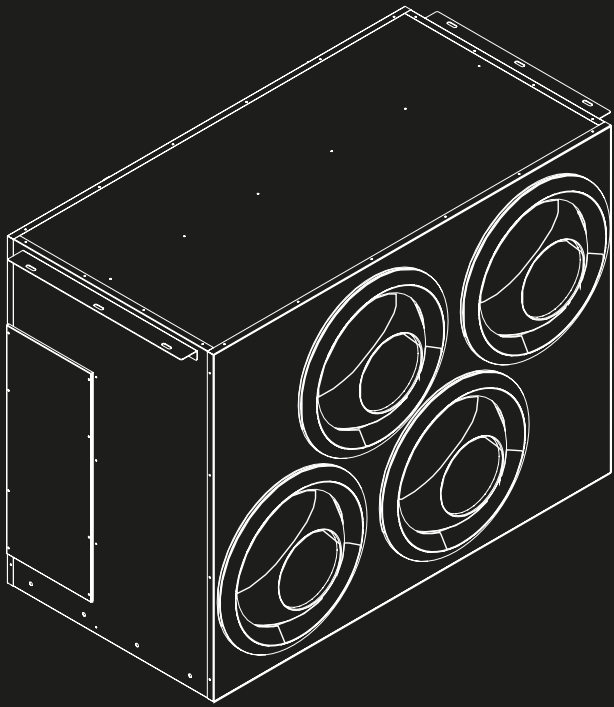

Panasonic[®]

N420890B Rev.01 02/2026

Jet Air Stream

P-VTVFA series**

First of all, we would like to thank you for having chosen one of our units.

As you will realise, you have made a winning choice by purchasing a product that represents the state of the art in domestic air-conditioning technology.

Thanks to the product you have purchased and by following the suggestions in this manual, you will benefit from optimal environmental conditions with the lowest possible energy investment.

Panasonic HVAC & CC Co., Ltd.

Compliance

This unit complies with European directives:

- Low Voltage Directive 2014/35/EU through adoption of the following technical standards: EN 60335-2-40: 2023, A11:23, EN 60335-1: 2012, A11:14, A13:17, A14:19, A1:19, A2:19, A15:21
- EMC Directive 2014/30/EU, through adoption of technical standards: EN IEC 61000-6-1:2019, EN IEC 61000-6-3:2021
- European Regulation ErP Ecodesign No. 2016/2281
- RoHS Directive 2011/65/EU by transposition of the following technical standards: EN IEC 63000:2018

Markings



CONTENTS

Compliance	2	5.3 How to check detailed settings 11, 12, 13 and 14	37
1. General information	4	5.4 How to adjust detailed settings using the remote controller	38
1.1 About the manual	4	5.5 Test run using the remote controller	40
1.2 General warnings	5	5.6 Main/sub remote controller setting	42
1.3 Basic safety rules.	6		
1.4 Disposal	6		
2. Product introduction	7	6. Maintenance	44
2.1 Identification	7	6.1 Routine maintenance	44
2.2 Destination of use	7		
2.3 Description of the appliance	7	7. Decommissioning	46
2.4 List of external components	8	7.1 Safety warnings	46
2.5 List of internal components	9		
2.6 Configurations	10	8. Faults and remedies	47
2.7 Compatible accessories	12	8.1 Preliminary warnings	47
		8.2 Anomalies reported by the control panel	47
3. Installation	13	8.3 Functional aspects not to be interpreted as faults	47
3.1 Preliminary warnings	13	8.4 Alarms displayed on the control panel	47
3.2 Reception	13		
3.3 Dimensions and weights with packaging	13	9. Technical information	50
3.4 Handling with packaging	14	9.1 Technical data.	50
3.5 Storage.	14	9.2 Fuse Characteristics	52
3.6 Unpacking.	14	9.3 Dimensions	52
3.7 Handling without packaging.	15	9.4 Wiring diagram.	54
3.8 Installation site.	15	9.5 Ecodesign classification.	56
3.9 Minimum installation distances.	17		
3.10 Positioning	19		
3.11 Refrigeration connections	20		
3.12 Condensate drain connection	24		
3.13 Aeraulic connections.	26		
3.14 Electrical connections	27		
4. Start-up	32		
4.1 Preliminary warnings	32		
4.2 First start-up	32		
4.3 Plant delivery	33		
4.4 Switching off for extended periods	33		
4.5 To adjust the fan static pressure	33		
5. Control configurations	34		
5.1 Automatic addressing procedure	34		
5.2 Automatic address setting via remote controller	35		

1. GENERAL INFORMATION

1.1 About the manual

This manual was written to provide all the explanations for the correct management of the appliance.

- ⚠ This instruction manual is an integral part of the appliance and must therefore be kept in a safe place and must ALWAYS accompany the appliance even if it is passed on to another owner or user, or transferred to another plant. If it is damaged or lost, download a copy from the website.
- ⚠ Read this manual carefully before proceeding with any operation and follow the instructions in the individual chapters.
- ⚠ Specific warnings are given in each chapter of the document and should be read before starting operations.
- ⚠ The Manufacturer accepts no liability for damage to persons or property resulting from failure to observe the regulations contained in this booklet.
- ⚠ This document is confidential under the terms of the law and may not be reproduced or passed on to third parties without the express authorisation of the Manufacturer.

Editorial pictograms

The pictograms in the following chapter provide quick and unambiguous information necessary for the correct and safe use of the machine.

Related to safety

⚠ High risk warning (bold text)

- The operation described above presents a risk of serious physical injury, fatality, major damage to the appliance and/or to the environment if not carried out in compliance with safety regulations.

⚠ Low risk warning (plain text)

- The operation described above presents a risk of minor physical injury or minor damage to the appliance and/or to the environment if not carried out in compliance with safety regulations.

⊘ Prohibition (normal text)

- Marks actions that are prohibited.

ⓘ Important information (bold text)

- This indicates important information that must be taken into account during the operations.

In the texts

Purpose of the actions

- ▶ Actions required

Expected responses following an action

- Lists

In the figures

- 1 The numbers indicate the individual components.

A Capital letters indicate a combination of components and dimensions.

- ① The white numbers in black marks indicate a series of actions to be carried out in sequence.
- Ⓐ The black letter in white identifies an image when there are several images in the same figure.

Pictograms on the product

Symbols are used in some parts of the appliance:

Related to safety



Read the instruction manual

Read the instructions carefully before performing any operation on the appliance.



Instruction manual

Read the information available in the technical documentation of the appliance.



Attention electrical hazard

- Warns relevant personnel of the presence of electricity and the risk of electric shock.



Maximum operating pressure

The indication "(X) MPa" specifies the numerical value of the maximum admissible pressure, expressed in megapascals (MPa).



Class III appliance

Related to the R32 refrigerant



Caution low-flammability material

- The refrigerant gas R 32 is mildly flammable and odourless. Avoid proximity to continuous ignition sources such as open flames, gas appliances, electric heaters, lit cigarettes, etc.



Instructions for the Authorised Service Centre

- The Authorised Service Centre must read the instructions before performing any operation on the appliance.

Recipients

User

Non-expert person capable of operating the product in safe conditions for people, for the product itself and the environment, interpreting an elementary diagnostic of faults and abnormal operating conditions, carrying out simple adjustment, checking and maintenance operations.

Installer

Expert person qualified to position and connect (hydraulically, electrically, etc.) the unit to the plant; this person is

responsible for handling and correct installation according to the instructions provided in this manual and the national standards currently in force.

Service

Expert and qualified person authorised directly by the Manufacturer to carry out all routine and supplementary maintenance operations, as well as every adjustment, check, repair and replacement of parts necessary during the life of the unit.

Organisation of the manual

The manual is divided into sections each dedicated to one or more target groups.

General information

It addresses all recipients.

It contains general information and important warnings that should be known before installing and using the appliance.

Product introduction

Addressed to all recipients, contains general information on the product.

Installation and Operation

It is addressed exclusively to the installer.

Contains specific warnings and all information necessary for positioning, mounting, connecting the device and operation.

Commissioning, maintenance and troubleshooting

They are addressed exclusively to the Authorised Service Centre.

It contains specific warnings and useful information for the most common commissioning and routine maintenance.

Decommissioning

It is addressed solely and exclusively to the Authorised Service Centre.

Technical information

It addresses all recipients.

It contains detailed technical information about the appliance.

1.2 General warnings

- ⚠ Specific warnings are given in each chapter of the document and should be read before starting operations.
- ⚠ All personnel involved must be aware of the operations and dangers that may arise when beginning all unit installation operations.
- ⚠ Installation performed outside the warnings provided in this manual and use of the appliance outside the prescribed temperature limits will invalidate the warranty.
- ⚠ Any contractual or extra-contractual liability for damage caused to persons, animals or property, due to installation, adjustment and maintenance errors or improper use is excluded. All uses not expressly indicated in this manual are not permitted.
- ⚠ The installation of the appliances must be carried out by a qualified company which, on completion of the work, will issue a declaration of compliance to the person in charge of the plant in accordance with the regulations in force and the instructions provided in the instruction booklet accompanying the appliance.
- ⚠ First start-up and repair or maintenance operations must be carried out by the Authorised Service Centre or by qualified personnel following the provisions of this manual.
- ⚠ Do not modify or tamper with the appliance as this can lead to dangerous situations.
- ⚠ Use suitable personal protective clothing and equipment during installation and/or maintenance operations. The Manufacturer is not liable for the non-observance of the current safety and accident prevention regulations.
- ⚠ In case of liquid or oil leaks, isolate the main power supply of the system and close any water valves. Promptly contact the Authorised Service Centre or professionally qualified personnel, and refrain from personally intervening on the equipment.
- ⚠ When replacing components, use only original spare parts.
- ⚠ The Manufacturer reserves the right to make changes to its models at any time to improve its product, without prejudice to the essential characteristics described in this manual. The Manufacturer is not obliged to add

such modifications to machines previously manufactured, already delivered, or under construction.

- ⚠ The appliance can be used by children aged 8 years and above and by persons with reduced physical, sensory, or mental capabilities, or those lacking experience or necessary knowledge, provided they are under supervision or have been given instructions concerning the safe use of the appliance and understand the hazards involved. Children should not play with the appliance. Cleaning and maintenance intended to be carried out by the user should not be done by children without supervision.

Specific warnings for R32

The document only contains some of the safety rules regarding R32 refrigerant. For more comprehensive information, please read the safety data sheet available from the retailer.

- ⚠ In each chapter, specific warnings are included for the operations described within. These warnings should be read before starting any activities.
- ⚠ All precautions regarding the handling of refrigerant must be followed in accordance with current regulations.
- ⚠ The unit uses R32 refrigerant, with a Global Warming Potential (GWP) of 675. Do not release R32 gas into the atmosphere.
- ⚠ The R32 refrigerant gas is mildly flammable and odourless.
- ⚠ Do not place flammable objects (spray cans) within 1 meter of the air discharge.
- ⚠ Avoid proximity to continuously operating ignition sources (open flames, gas appliances, electric stoves, lit cigarettes, etc.).
- ⚠ In case of refrigerant gas leakage, ventilate the area thoroughly and move away. Promptly call the Authorised Service Centre or professionally qualified personnel and do not personally intervene on the appliance.

1.3 Basic safety rules

Please note that the use of products that operate with electrical energy requires compliance with some fundamental safety rules such as:

- ⊖ It is forbidden to touch the appliance with wet or damp body parts.
- ⊖ It is forbidden to carry out any operation before disconnecting the appliance from the power supply by setting the plant master switch to "OFF".
- ⊖ It is forbidden to modify the safety or adjustment devices without the authorisation and instructions of the appliance manufacturer.
- ⊖ It is forbidden to pull, unplug or twist the electrical cables coming out of the appliance, even if it is disconnected from the mains supply.
- ⊖ It is forbidden to introduce objects and substances through the openings provided for the intake and delivery of air.
- ⊖ It is forbidden to open the access doors to the internal parts of the appliance without first setting the plant master switch to "OFF".
- ⊖ It is forbidden to dispose of packaging material and leave it within reach of children as it can be a potential hazard.

1.4 Disposal



The symbol on the product or packaging indicates that the product should not be treated as normal household waste. Instead, it should be taken to an appropriate collection point for recycling of electrical, electronic, and battery equipment.

Proper disposal of this product avoids harm to humans and the environment and promotes the reuse of valuable raw materials.

For more detailed information about the recycling of this product, contact your local authority, your household waste disposal service, or the shop where you purchased the product.

Illegal disposal of the product by the user involves the application of the administrative sanctions provided for by the regulations in force.

This provision is only valid in the EU Member States.

- ⚠ Avoid disassembling the appliance yourself.
- ⚠ **Contact an Authorised Service Centre to disassemble the appliance.**



This symbol could be used in combination with a chemical symbol.

In such case, it complies with the requirements set by the directive for the chemical substance involved.

2. PRODUCT INTRODUCTION

2.1 Identification

The appliance can be identified by the rating plate:

1. Technical rating plate

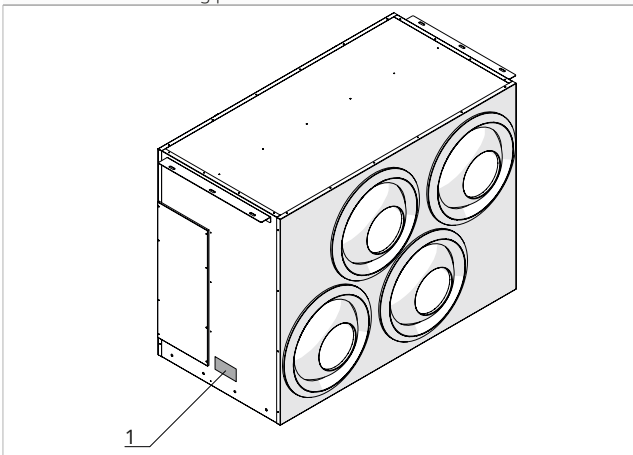

Technical rating plate

This shows the technical and performance specifications of the appliance.

- ⚠ Tampering with, removing or missing identification plates does not allow the product to be reliably identified by its serial number and therefore invalidates the warranty.
- ⚠ This Jet Stream unit is a part-unit air conditioner, complying with the part-unit requirements of this International Standard, and must only be connected to other units that have been confirmed as complying with the corresponding part-unit requirements of this International Standard.

2.2 Destination of use

The appliance is a system designed for large environments, such as industrial halls and extensive spaces. A cutting-edge solution that ensures maximum comfort and cost-effectiveness. It may be equipped, on the internal unit, with the SmartJet system: an innovative system with motorised and self-directing nozzles that independently and au-

tonomously regulate the direction and temperature of the air to prevent stratification and maintain the desired temperature in the occupied area. This appliance is intended to be used by expert or trained users in shops, light industry, and farms, or for commercial use by laypersons.

2.3 Description of the appliance

Structure: internally coated and galvanized sheet metal.

Brushless fans: radial fans with backward-facing blades.

Heat exchanger: air-to-air type made of copper-aluminum material.

Motorised nozzles: allow for the direction of airflow based on the temperature of the supplied air.

Filters: G2 flat metallic filters with all galvanized components

Models: 2 sizes with different flow rates are available.

Versions: there are three different versions available, which can be requested based on individual preferences.

- M: Smart Jet version with automatic nozzles
- N: Version with manual nozzles
- P: Ducted version

2.4 List of external components

- 1. Nozzle / motorised nozzle
- 2. Electrical panel

- 3. Installation bracket

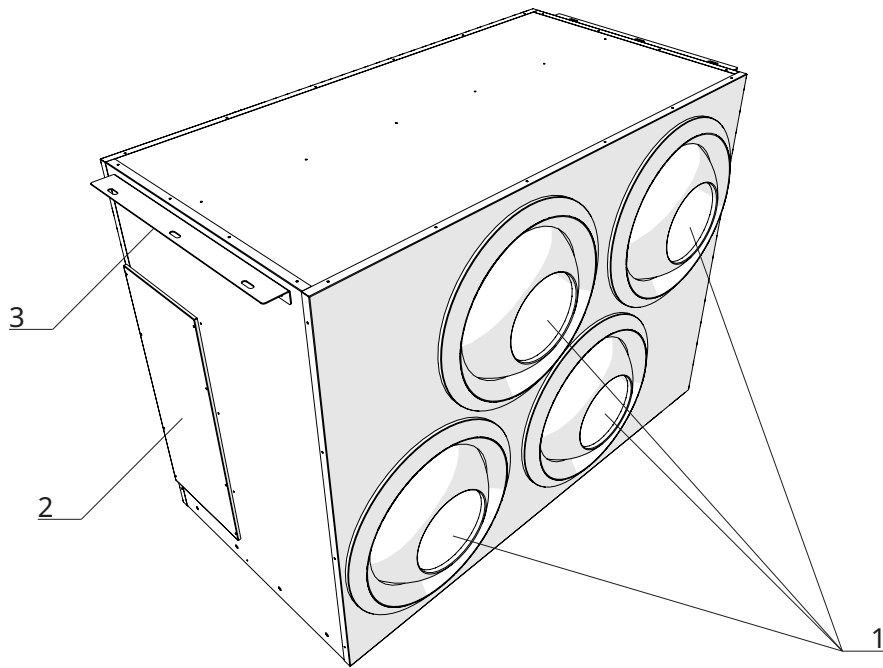

Size 140

- 1. External unit connection 3/8"
- 2. External unit connection 5/8"
- 3. Condensate drain

- 4. Extract air filter
- 5. Electrical connection passage

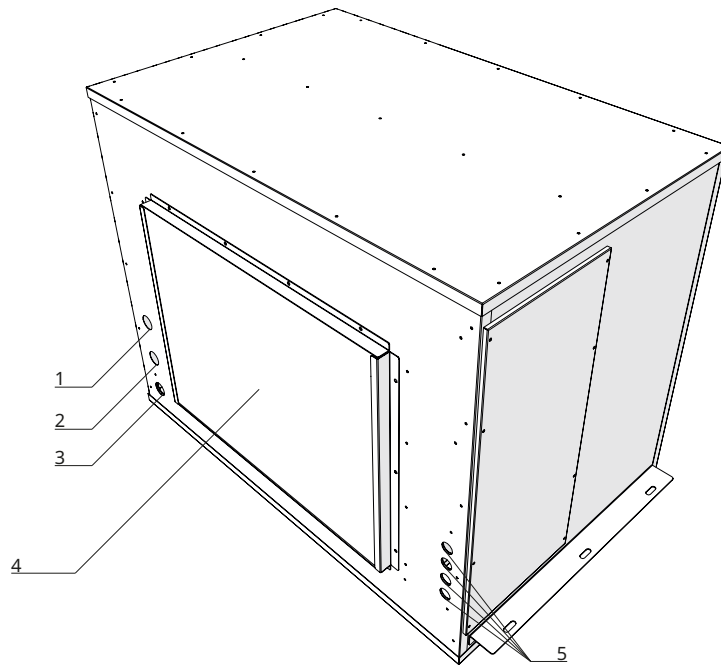

Size 250

- | | | | |
|----|-------------------------------|----|-------------------------------|
| 1. | External unit connection 7/8" | 4. | Extract air filter |
| 2. | External unit connection 1/2" | 5. | Electrical connection passage |
| 3. | Condensate drain | | |

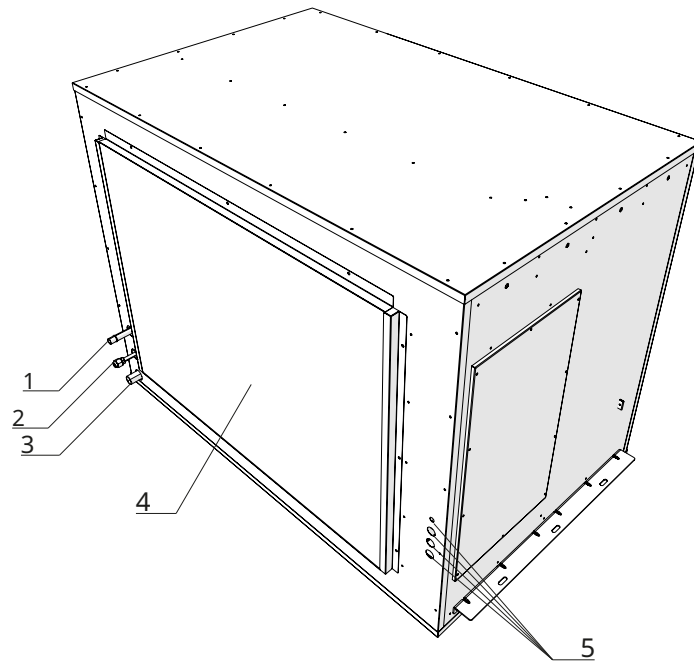
**2.5 List of internal components**

- | | | | |
|----|-----|----|----------------|
| 1. | Fan | 2. | Heat exchanger |
|----|-----|----|----------------|

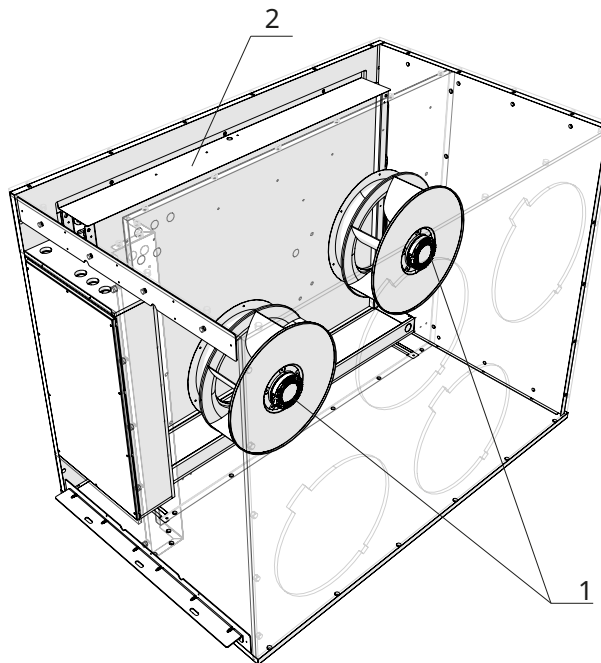

2.6 Configurations

Size 140

A M: Smart Jet version with automatic nozzles (P-VTVF140MC5A-PE)

B N: Version with manual nozzles ((P-VTVF140NC5A-PE)
C P: Ducted version (P-VTVF140PC5A-PE)

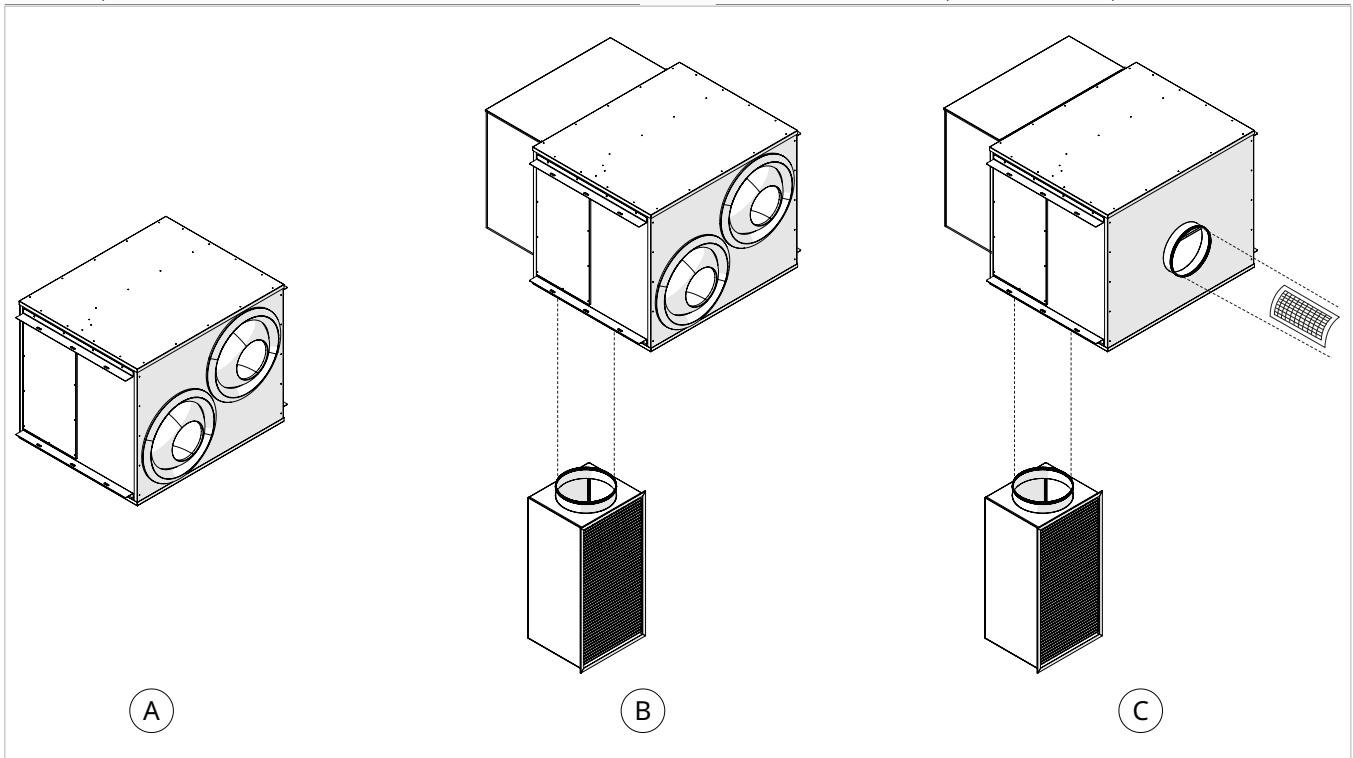

Size 250

A M: Smart Jet version with automatic nozzles ((P-VTVF250MC5A-PE)

B N: Version with manual nozzles (P-VTVF250NC5A-PE)
C P: Ducted version (P-VTVF250PC5A-PE)

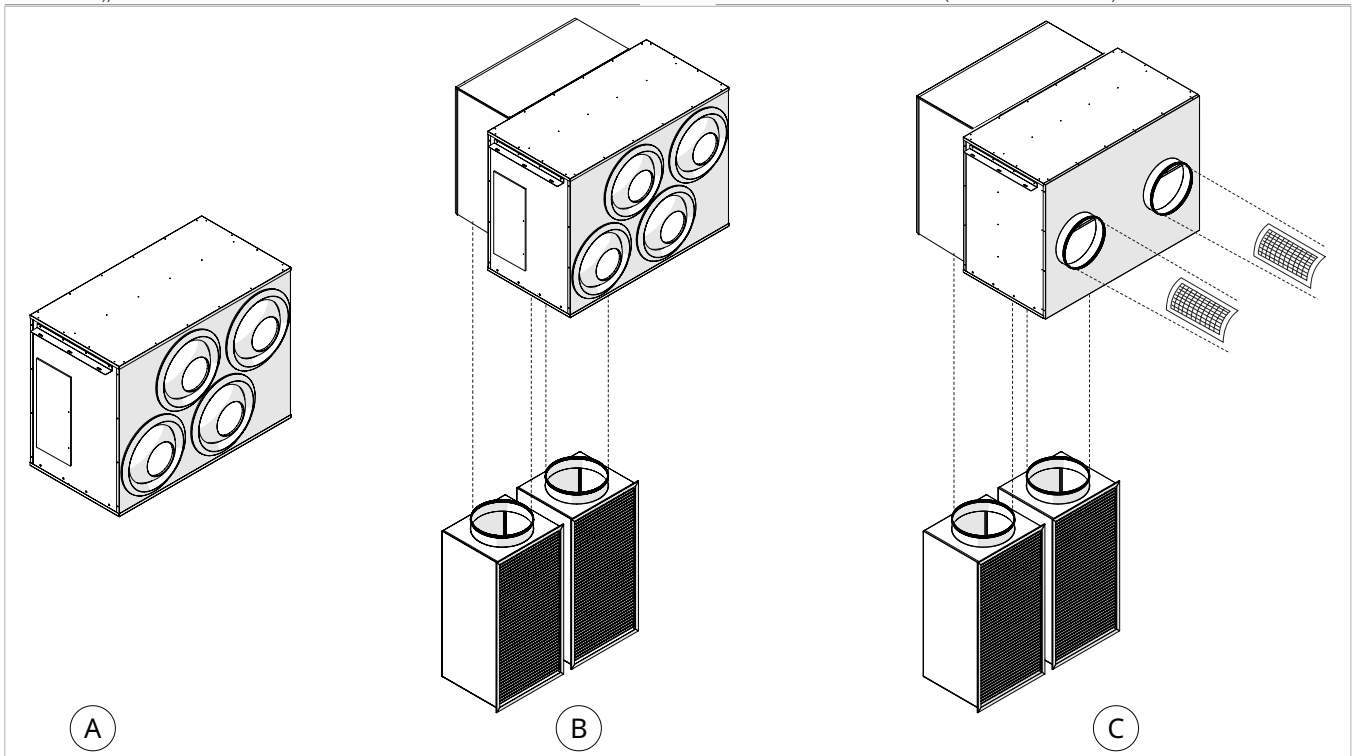

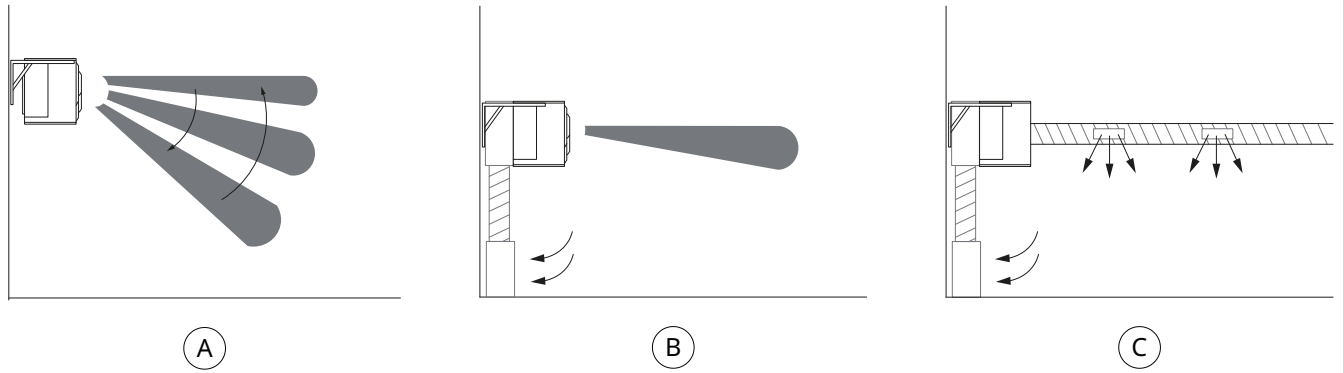
A M: Smart Jet version with automatic nozzles**C** P: Ducted version**B** N: Version with manual nozzles

Nozzle rotation

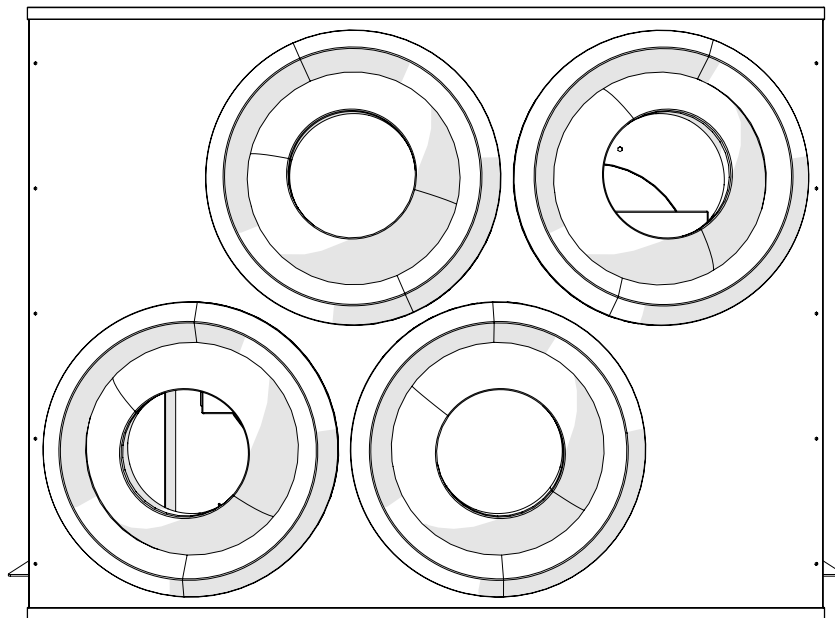



The nozzle can move exclusively on one axis, automatically or manually, depending on the model.

On all models, however, it is possible to rotate the nozzle by acting on the front screws located behind the cover: simply unscrew the screws, position the nozzle according to the pre-defined degree adjustments determined by the pre-drilled holes, then screw it back in.

La rotazione avviene su un unico asse e, in base all'inclinazione dell'ugello, il flusso viene direzionato nella corrispondente direzione.

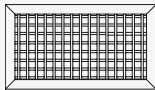
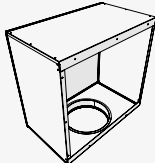
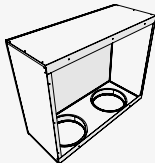
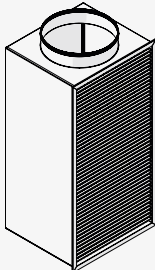
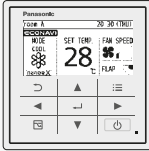
2.7 Compatible accessories

Description	Code
Duct grille for air supply	
	Duct grille for air supply for ducted configurations for size 140 and 250 PCZ-AHRX0071
Ducted air intake plenum kit	
	Rear air suction module with lower connection for displacement module for size 140 PCZ-AHRX0056
	Rear air suction module with lower connection for displacement module for size 250 PCZ-AHRX0057
Ground air intake module	
	Floor air suction module for displacement supplied complete with grille and filter for size 140 PCZ-AHRX0061
Controls	
	Design wired remote controller CZ-RTC5B
	CONEX - Wired remote controller CZ-RTC6 CZ-TRC6BL CZ-RTC6BLW2
	CZ-RTC6W CZ-RTC6WBL CZ-RTC6WBLW2

⚠ For size 250 it is necessary to order 2 pieces of accessory PCZ-AHRX0061.

3. INSTALLATION

3.1 Preliminary warnings

- ⚠ **For detailed information on the products, refer to chapter "Technical information" p. 50.**
- ⚠ Installation must be carried out by the installer. If installation is not performed correctly, there may be a risk of refrigerant and water leakage, electric shock or fire.
- ⚠ During installation, it is necessary to observe the precautions mentioned in this manual, and on the labels affixed to the inside of the appliances, as well as to take every precaution suggested by common sense and the safety regulations in force at the place of installation.
- ⚠ It is recommended to use only the specific installation components supplied. The use of alternative components may cause refrigerant and water leakage, electric shocks or fire.
- ⚠ Failure to apply the indicated rules may cause malfunctions of the appliance and relieves the Manufacturer from any warranty and from any damage caused to persons, animals or property.

Preliminary warnings for R32

- ⚠ Before working on systems containing flammable refrigerants, it is necessary to perform safety checks to ensure that the risk of combustion is minimised.
- ⚠ The appliance must be protected from accidental impacts to prevent mechanical damage.
- ⚠ Do not pierce or burn.

3.2 Reception

Preliminary warnings

- ⚠ Upon receipt of the package check that it is not damaged, otherwise accept the goods with reservation, producing photographic evidence of any damage.
- ⚠ In the event of damage, notify the shipper by registered mail with return receipt within 3 days of receipt. Presenting photographic documentation, similar information should also be sent by email to the Manufacturer.
- ⚠ No reports of damage will be taken into account later than 3 days after delivery.
- ⚠ The packaging should be transported in a vertical position without tilting. If it is tilted, please notify the carrier immediately.

Package description

The packaging is made of suitable material and carried out by experienced personnel. The units are all checked and tested and are delivered complete and in perfect condition. The appliance is shipped in standard packaging consisting of a cardboard box and a set of polystyrene foam protectors, placed on a wooden pallet and secured with straps.

3.3 Dimensions and weights with packaging

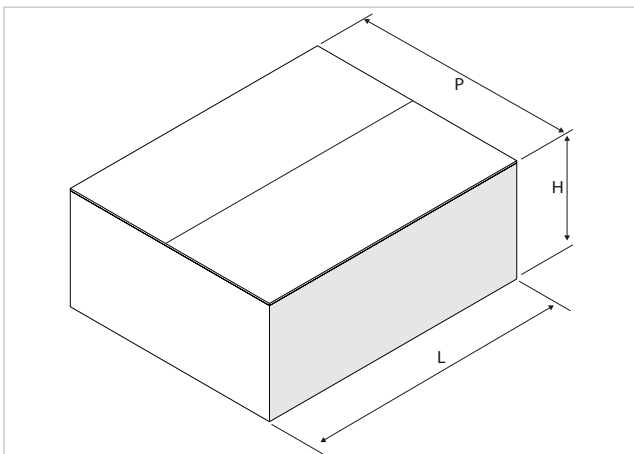

Models	u.m.	P-VTVF140xC5A-PE	P-VTVF250xC5A-PE
Packaging dimensions			
Width	mm	1.195	1.550
Depth	mm	1.010	1.060
Height	mm	990	1.220
Weight	kg	98,0	145,0

3.4 Handling with packaging

Preliminary warnings

- ⚠ The product should only be handled by qualified personnel, adequately equipped, and using tools suitable for the weight and dimensions of the product.
- ⚠ Before each handling operation, check the lifting capacity of the machinery used in accordance with the indications on the packaging.

- ⚠ The packaging must be transported in a vertical position without being tilted.
- ⚠ When the load is lifted from the ground, stay clear of the immediate and surrounding area.
- ⚠ Check the information on the packaging for the amount of stackable packages.
- ⚠ In manual operations, the maximum weight per person required by current legislation must always be observed.

Handling

With pallet:

- ▶ Use a forklift truck

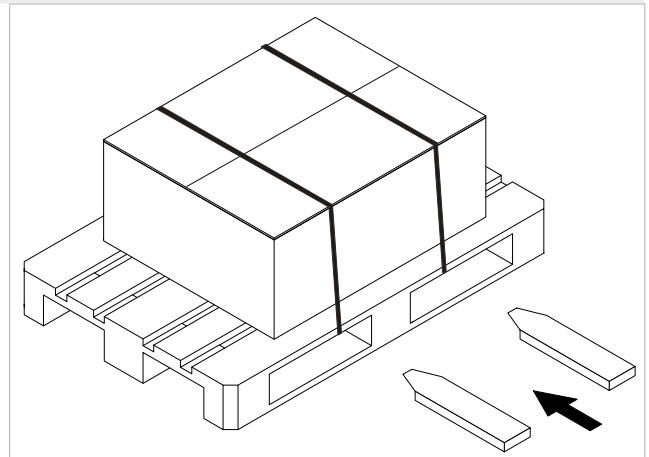

3.5 Storage

Preliminary warnings

- ⚠ Stored in accordance with the applicable national regulations.
- ⚠ Store in a closed environment protected from the weather, off the ground by means of sleepers or pallets

with temperatures not below 0 °C, up to a maximum of 40 °C.

- ⚠ Do not overturn the packaging.
- ⚠ Place the appliance only in a vertical position.

3.6 Unpacking

Preliminary warnings

- ⚠ Check that the individual components are present.
- ⚠ Check that no components were damaged during transport.
- ⚠ Dispose of the packaging components following the applicable waste disposal regulations. Check for disposal arrangements with your local authority.
- ⚠ Handle with care.
- ⚠ The appliance must always be moved in a vertical position.
- The packing material (cardboard, staples, plastic bags, etc.) must not be dispersed or abandoned in the surrounding environment and must be kept out of reach of children due to risk of hazard.

Removing the packaging

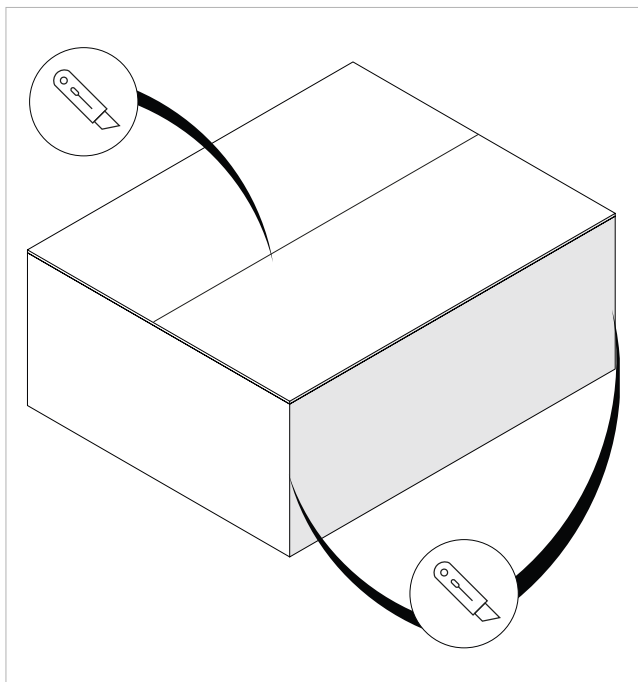

To remove the packaging:

- ▶ Use a cutter
- ▶ Open the cardboard packaging
- ⓘ To aid removal of the product, also cut the vertical edges.
- ▶ Remove the supplied components
- ▶ Remove the polystyrene elements
- ▶ Remove the appliance from the box

Accompanying material

They are included with the appliance, inside the packaging:

- Indoor unit installer manual
- User manual
- Tube for gas connection (only for size 30)
- ⚠ Check the presence of the individual components.

3.7 Handling without packaging

Preliminary warnings

- ⚠ The appliance must be handled only by qualified personnel, adequately equipped and with equipment suitable for the weight and dimensions of the appliance.
- ⚠ The unit must be handled using non-slip gloves.
- ⚠ Before each handling operation, check the lifting capacity of the machinery used in accordance with the indications on the packaging.
- ⚠ When the load is lifted from the ground, stay clear of the immediate and surrounding area.
- ⚠ Check the information on the packaging for the amount of stackable packages.

- ⚠ In manual operations, the maximum weight per person required by current legislation must always be observed.

Movement methods

- ▶ Use a forklift truck, a mobile scaffold or another suitable lifting system
- ⚠ The unit can only be moved manually for short trips in exceptional cases. In this case it is necessary to carefully check that the weight of the unit does not exceed what is stipulated by the regulations with respect to the number of persons employed.

3.8 Installation site

The location of the appliance must be determined by the plant engineer or a competent person and must take into account both purely technical requirements and any national/local legislation in force.

The device is intended to be installed indoors in a vertical position, fixed to the wall.

- ⚠ The installation position must be chosen close to a wall connected to the outside.

Preliminary warnings

- ⚠ Avoid installing the unit in the vicinity of:
 - obstacles or barriers that cause recirculation of the exhaust air
 - narrow places where the sound level of the appliance can be enhanced by reverberations or resonances

- environments with the presence of flammable or explosive gases
- very damp environments (laundries, greenhouses, bathrooms with high humidity, etc.) to prevent the formation of condensation on the external panels of the unit
- environments with the presence of flammable or explosive gases or flammable fluids
- solar radiation and proximity to heat sources
- ⚠ Avoid placing the unit within 1 metre of radio and video equipment.
- ⚠ Do not install above heat sources.
- ⚠ Ensure that:
 - the installation site of the unit must be chosen with the utmost care to guarantee adequate protection from shocks and consequent damage

- the supporting surface is capable of supporting the weight of the appliance
 - the supporting surface does not affect load-bearing building elements, piping, or power lines
 - the functionality of load-bearing elements is not compromised
 - there are no obstacles to the free circulation of air through the holes (plants, leaves...)
 - the appliance must be installed in a position where it can be easily serviced
 - the safety distances between the units and other appliances or structures are scrupulously respected so that the air entering and leaving the fans is free to circulate
- ⚠ If improperly installed or placed on an unsuitable surface, the unit, if detached from its base, may cause damage to persons or property.
- ⚠ The appliance must not be in a position where the air flow is aimed directly at a person.
- ⚠ Provide the following:
- a drain nearby for the outflow of condensation
 - a compliant power supply nearby

Preliminary warnings for R32

- ⚠ The appliance must be installed in well-ventilated environments that have a minimum floor area as indicated in the table "Minimum Floor Area" based on the total refrigerant charge of the circuit.
- ⚠ **The refrigerant charge refers to the total amount of refrigerant in the circuit, which includes the factory charge and any additional charge.**
- ⚠ Please refer to the technical rating plate on the associated outdoor unit for the quantity of refrigerant loaded into the unit.
- ⚠ If the appliance is placed in a poorly ventilated area, precautions must be taken to prevent the accumulation of leaked refrigerant, thus avoiding the risk of fire or explosion.
- ⚠ The appliance should be placed in a room where there are no continuously operating open flames (such as a gas appliance in operation) or ignition sources (such as an operating electric heater).
- ⚠ Any ventilation openings must be kept clear of obstacles.
- ⚠ Perform the following checks:
- Perform safety checks to ensure that the risk of combustion is minimised
 - avoid working in confined spaces
 - delimit the area around the workspace
 - ensure safe working conditions around the area by checking for flammable materials

Minimum floor area - Model 140				
M (kg)	Unit installation height (m)			
	3	4	5	6
A _{min} (m ²)				
3,00	3,1	1,7	1,1	0,8
3,10	3,3	1,8	1,2	0,8
3,20	3,5	2,0	1,3	0,9
3,30	3,7	2,1	1,3	0,9
3,40	3,9	2,2	1,4	1,0
3,50	4,2	2,3	1,5	1,0
3,60	4,4	2,5	1,6	1,1
3,70	4,7	2,6	1,7	1,2
3,80	4,9	2,8	1,8	1,2
3,90	5,2	2,9	1,9	1,3
4,00	5,4	3,1	2,0	1,4
4,20	6,0	3,4	2,2	1,5
4,40	6,6	3,7	2,4	1,6
4,60	7,2	4,1	2,6	1,8
4,80	7,8	4,4	2,8	2,0
5,00	8,5	4,8	3,1	2,1
5,20	9,2	5,2	3,3	2,3
5,40	9,9	5,6	3,6	2,5
5,60	10,7	6,0	3,8	2,7
5,80	11,5	6,4	4,1	2,9
5,97	12,2	6,8	4,4	3,0

1. **M** Refrigerant charge
2. **A_{min}** Minimum floor area

Minimum floor area - Model 250				
M (kg)	Unit installation height (m)			
	3	4	5	6
	A _{min} (m ²)			
4,80	7,8	1,7	1,1	0,8
5,00	8,5	1,8	1,2	0,8
5,20	9,2	2,0	1,3	0,9
5,40	9,9	2,1	1,3	0,9
5,60	10,7	2,2	1,4	1,0
5,80	11,5	2,3	1,5	1,0
6,00	12,3	2,5	1,6	1,1
6,20	13,1	2,6	1,7	1,2
6,40	13,9	2,8	1,8	1,2
6,60	14,8	2,9	1,9	1,3
6,80	15,7	3,1	2,0	1,4
7,00	16,7	3,4	2,2	1,5
7,40	18,6	3,7	2,4	1,6
7,80	20,7	4,1	2,6	1,8
8,20	22,9	4,4	2,8	2,0
8,60	25,2	4,8	3,1	2,1
9,00	27,6	5,2	3,3	2,3
9,40	30,1	5,6	3,6	2,5
9,80	32,7	6,0	3,8	2,7
10,20	35,4	6,4	4,1	2,9
10,40	36,8	6,8	4,4	3,0

3. **M** Refrigerant charge
 4. **A_{min}** Minimum floor area

3.9 Minimum installation distances

The clearance zones for the installation and maintenance of the appliance are shown in the figure below. Established spaces are necessary to avoid barriers to airflow and allow for normal cleaning and maintenance.

- ⚠ Make sure that there is sufficient space to allow the panels to be removed for routine and supplementary maintenance operations.
- ⚠ Ensure a spacious and open area in front of the unit to guarantee proper airflow.

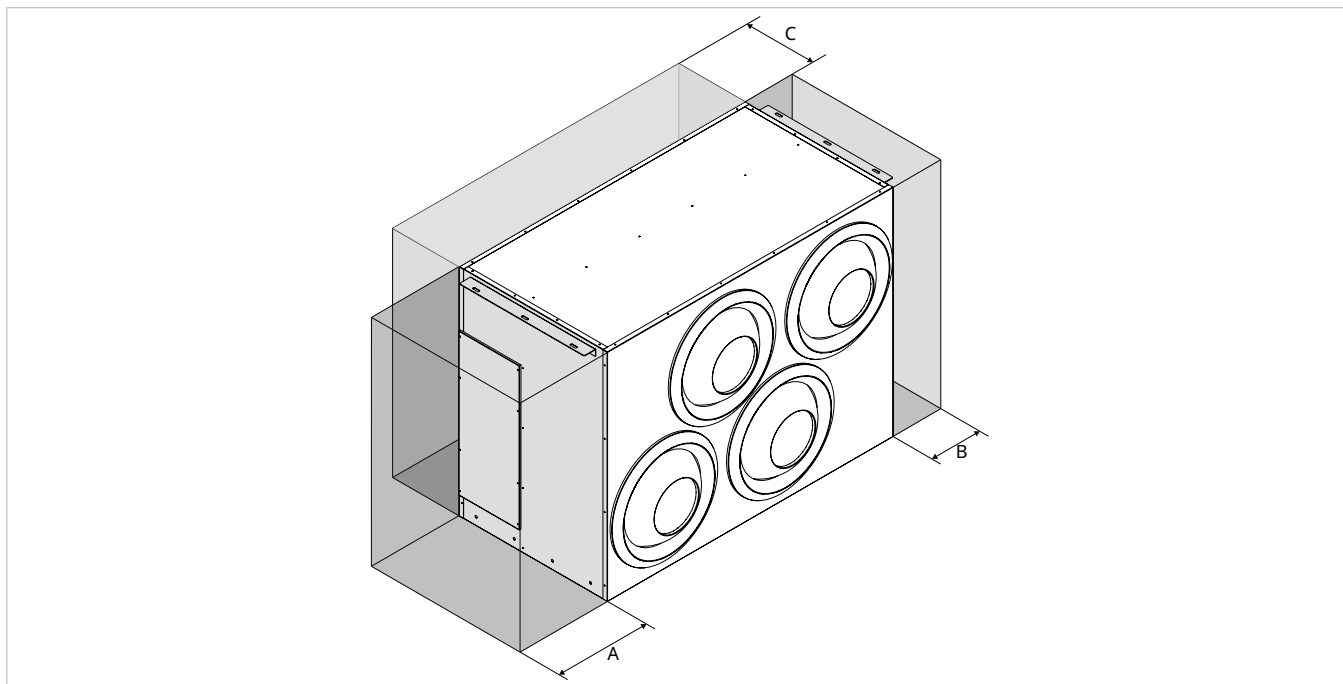

Models	u.m.	P-VTVF140xC5A-PE	P-VTVF250xC5A-PE
Minimum distances			
A	mm	500	500
B	mm	200	200
C	mm	300	300

Installation height limits

- A** Minimum installation height
- B** Maximum installation height

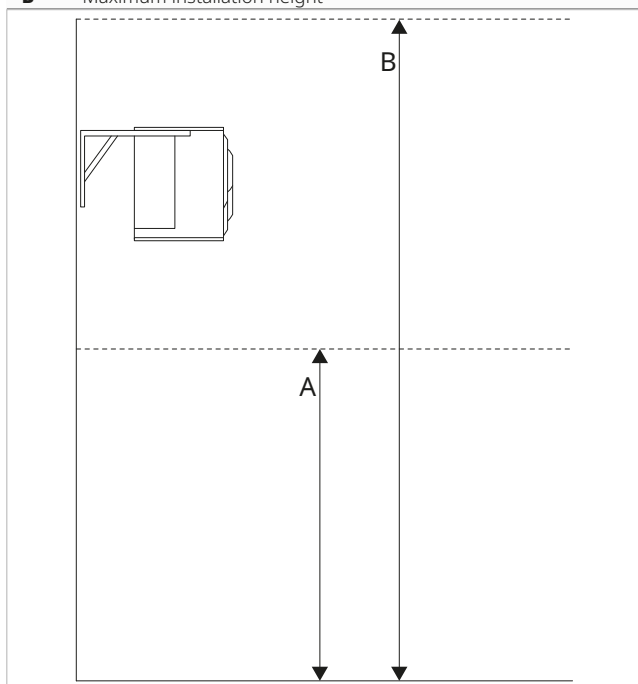

Models	u.m.	P-VTVF140xC5A-PE	P-VTVF250xC5A-PE
Installation limits			
A	mm	3.000	3.000
B	mm	6.000	6.000

- ⚠ The established heights are necessary to ensure the proper functioning of the unit.
- ⚠ Other installation heights are possible. For further details, contact the local sales representative.

3.10 Positioning

Preliminary warnings

⚠ Check that:

- the surface supports the weight of the appliance
- the surface does not affect piping or power lines
- the functionality of load-bearing elements is not compromised

Positioning the unit

The unit can be installed in two different ways:

- Vertical ceiling installation
- Vertical wall installation

Installation brackets

The unit is supplied with installation brackets positioned laterally.

It is possible to modify the position of the brackets.

1. Upper installation bracket

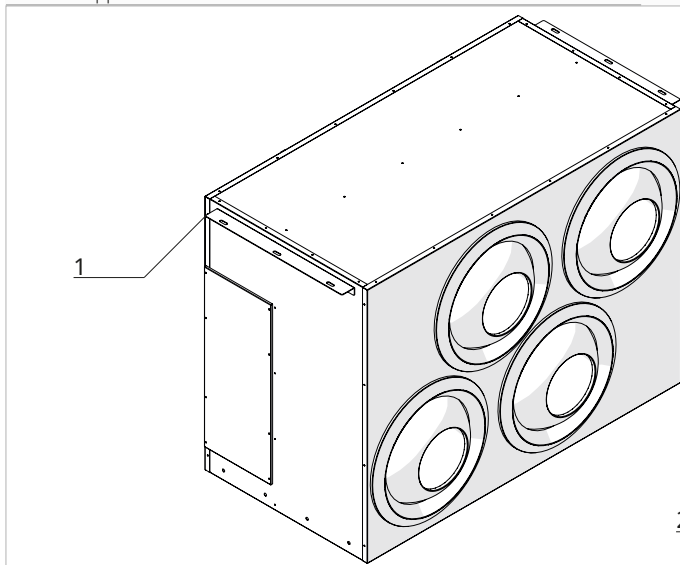

2. Lower installation bracket

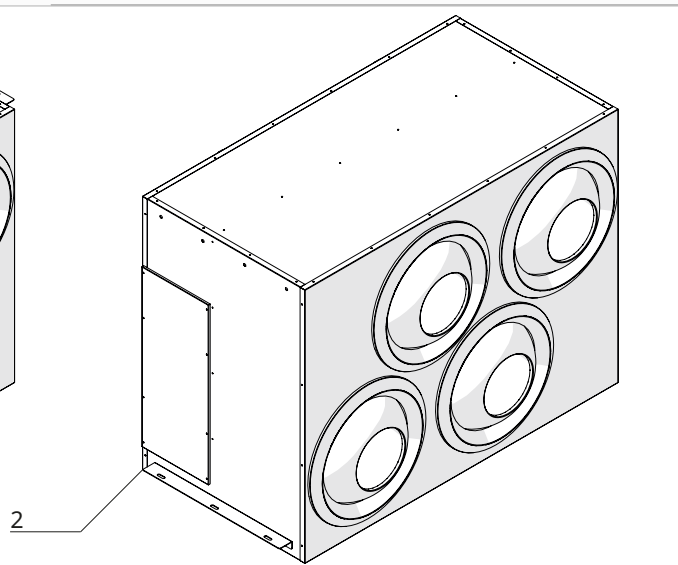

To modify the position of the brackets:

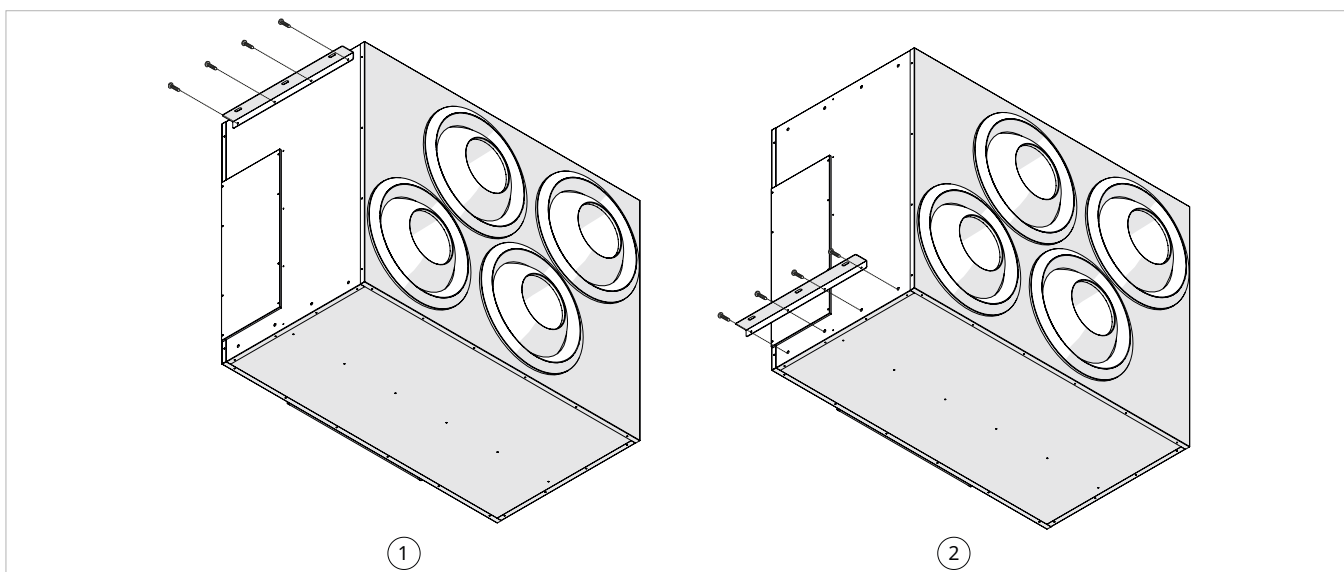

- ▶ Remove the screws from the installation bracket
- ▶ Install the bracket on the upper part of the unit using the screws previously removed

Wall installation

⚠ Check the correct orientation of the unit.

- A** Unit installed with the bracket in the upper position
- B** Unit installed with the bracket in the lower position

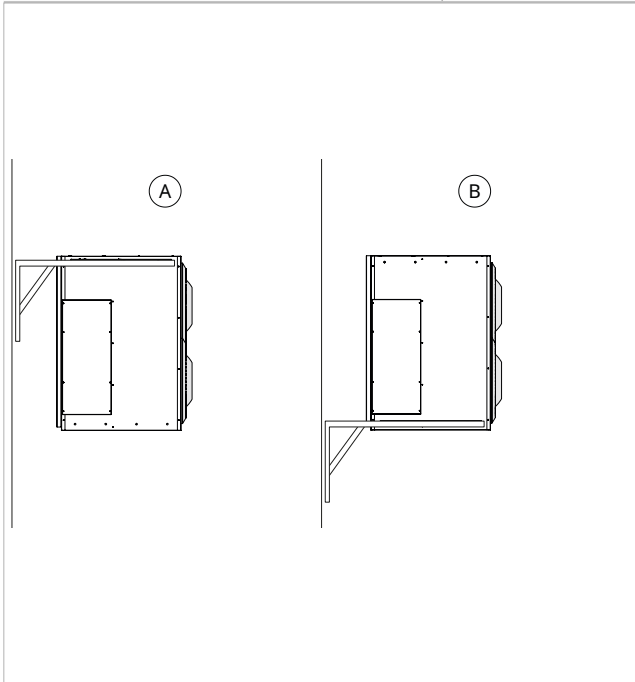

- ▶ Mark the position of the fixing holes
- ▶ Use fixing systems appropriate for the type of supporting surface and the weight of the unit
- ▶ Secure the unit to the fixing system

Check that:

- it is levelled
- the minimum distances and installation height limits are respected

Ceiling installation

⚠ Check the correct orientation of the unit.

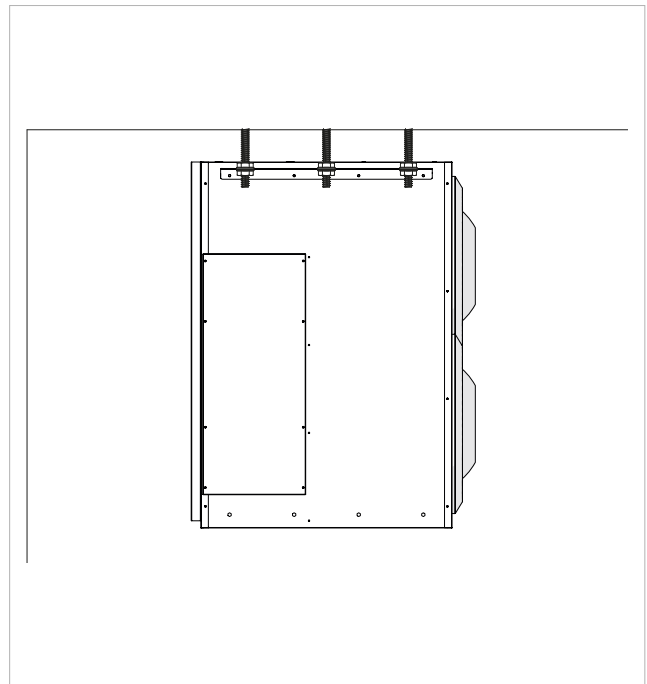

- ▶ Mark the position of the fixing holes
- ▶ Use fastening systems suitable for the type of support surface and the weight of the unit
- ▶ Secure the unit to the fastening system

Check that:

- it is levelled
- the minimum distances and installation height limits are respected

3.11 Refrigeration connections

Preliminary warnings

- ⚠ **The installer must comply with Regulation 303/2008/EC, which, in accordance with Directive 842/2006/EC, defines the requirements for companies and personnel concerning the fixed refrigeration, air conditioning, and heat pump equipment containing certain fluorinated greenhouse gases.**
- ⚠ **For dimensional information, refer to the chapter "Technical information" p. 50.**
- ⚠ Use equipment suitable for the system refrigerant.
- ⚠ Identify the piping route to minimise tubing length and bends, maximising system efficiency.
- ⚠ The refrigerant lines should be as straight as possible, and any necessary bends must have a radius greater than 40 mm.
- ⚠ Use exclusively copper pipes specifically designed for refrigeration.
- ⚠ The pipes must be supplied clean and sealed at the ends. It is possible to use pre-insulated copper pipes for refrigeration.

- ⚠ The pipes must not contain residues of debris, dirt, or water that could damage the components of the unit and compromise the proper functioning of the appliance.
- ⚠ Handle the refrigerant with care. Leaking refrigerant can cause frostbite.
- ⚠ For safety and installation requirements relating to the outdoor unit and overall system installation, please refer to the relevant outdoor unit documentation.
- ⊖ It is forbidden to use pipes with a diameter different from that indicated in the technical data table.
- ⊖ Using refrigerant lines that have been previously used is prohibited as the seal at the flare connection cannot be guaranteed.
- ⊖ Connecting using regular hydraulic pipes is prohibited.
- ⊖ Welding is prohibited in the presence of refrigerant within the refrigeration circuit. If necessary, the refrigerant must be recovered, and the circuit cleaned using oxygen-free nitrogen.

Specific warnings for R32

- ⚠ The length of the connecting pipes must be minimised.
- ⚠ Connecting pipes must be shielded from physical damage and should not be installed in an unventilated space smaller than the area specified in the Minimum Floor Area table.
- ⚠ The connecting pipes must be installed in a position unlikely to be exposed to corrosive substances, unless they are made from materials inherently corrosion-resistant or adequately protected against corrosion.
- ⚠ Compliance with national regulations for the gas used is mandatory.
- ⚠ Refrigerant connections must be accessible for maintenance purposes.
- ⚠ Work must be undertaken following a controlled procedure to minimise the risk of presence of flammable gases or vapors while the work is being carried out.
- ⊖ Performing hot work (welding, brazing, etc.) is prohibited.
- ⚠ To make refrigerant connections, the following precautions must be taken:

Area checks

- Perform safety checks to ensure that the risk of combustion is minimised
- avoid working in confined spaces
- delimit the area around the workspace
- ensure safe working conditions around the area by checking for flammable materials

Refrigerant fluid presence checks

- the area must be checked with a specific refrigerant fluid detector before and during work, so the technician is aware of potentially flammable atmospheres
- ensure that the leak detection apparatus is suitable for use with flammable refrigerants, meaning it does not produce sparks, is properly sealed, or inherently safe
- ⊖ Using combustion-based refrigerant fluid detectors, such as a halide torch or any other system using an open flame, is prohibited.

Combustion source checks

- people performing work on a refrigeration system involving exposed piping containing or having contained a flammable refrigerant fluid must refrain from using any combustion source that could lead to the risk of fire or explosion
- all potential combustion sources, including smoking a cigarette, must be kept sufficiently far from the work area during operations in which flammable refrigerant fluid could be released into the surrounding space
- check the surrounding area of the equipment to ensure there are no fire hazards or combustion risks
- place signs stating "No Smoking"

Ventilation area checks

- ensure the area is adequately ventilated
- during work, there must be a continuous level of ventilation

- ventilation should safely disperse any released refrigerant fluid and preferably expel it outside into the atmosphere

Leak detection

- ⊖ Using combustion-based refrigerant fluid detectors, such as a halide torch or any other system using an open flame, is prohibited.
- ⚠ For leak detection, follow the following instructions:
 - use electronic detectors to search for flammable refrigerant fluids
 - before usage, ensure the detectors are properly calibrated
 - calibration operations must be carried out in an area free from refrigerant fluid
 - ensure the detector is not a potential ignition source and is suitable for the refrigerant fluid used
 - if a leak is suspected, all open flames must be eliminated
 - in the event of a leak requiring brazing, it is mandatory to recover all refrigerant fluid from the system or isolate it (using shut-off valves) in a part of the system away from the leak
- ⚠ The use of silicone sealant can compromise the effectiveness of certain types of leak detection instruments.

Recharge procedure

- ⚠ For the recharge procedure, ensure that:
 - there is no contamination between different refrigerant fluids
 - the charging equipment's flexible hoses are as short as possible to minimise the amount of refrigerant fluid
 - the cylinders are kept in an upright position
 - ground the refrigeration system before proceeding with the charge
- ⚠ Before proceeding with the charge, ensure that the leak check has been performed.
- ⚠ Check for refrigerant leaks before leaving the site.
- ⚠ Label the system with the refrigerant charge when the charge is complete.
- ⊖ Overloading the refrigeration circuit is prohibited.
- ⊖ It's prohibited to introduce a refrigerant fluid into the system other than the one indicated or to mix different refrigerant fluids.

Connection diagram

1. Liquid line
2. Gas line

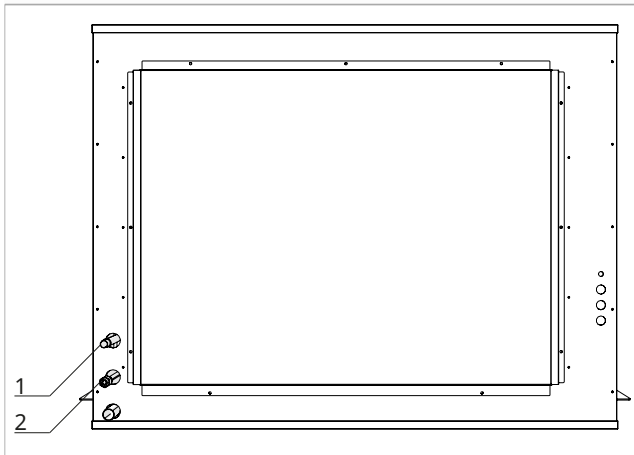

Piping connection

The refrigerant fittings, equipped with shut-off valves, are designed for flare or solder connections.

Preliminary warnings

- ⚠ Mount a cable duct (preferably with internal separators) of suitable dimensions on the wall to later pass the pipes and electrical cables through.
- ⚠ Cut the pipe sections with an excess of approximately 3-4 cm in length.
- ⚠ Immediately after cutting and deburring, seal the tube ends with insulating tape.
- ⚠ Remove any burrs using the appropriate tool.
- ⚠ Make the cut solely using a tube cutter wheel, tightening at small intervals to avoid crushing the pipe.
- ⚠ **Never use a regular saw to cut the pipes; debris could enter the pipe and later circulate within the system, causing severe damage to the components.**
- ⚠ Avoid the introduction of non-condensable gases (such as air) into the circuit; otherwise, during operation, high pressures might occur, risking ruptures.

Flare connection

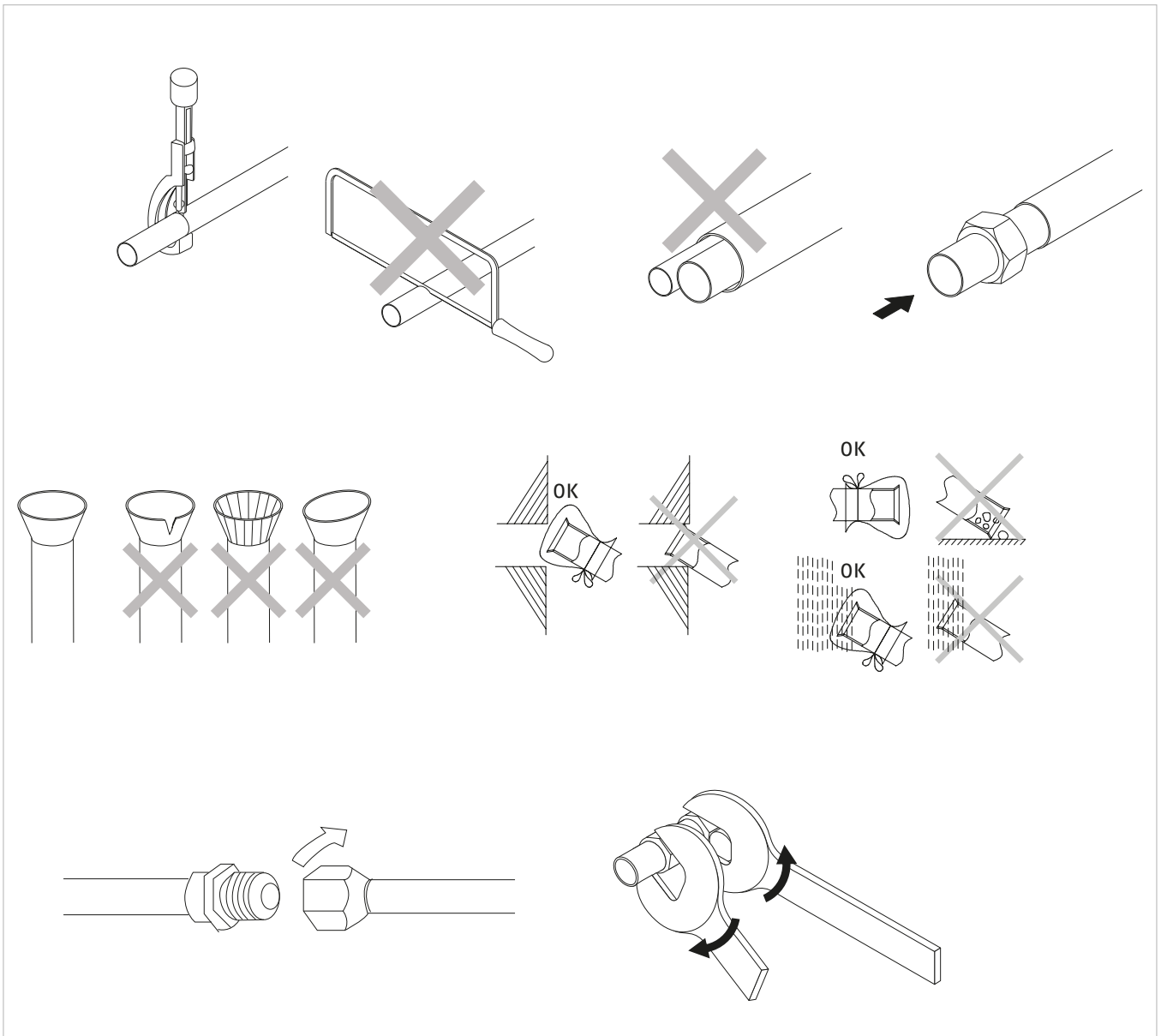

Before connecting:

- ▶ Insert the fastening nut into the pipe
- ▶ Perform flaring on the pipe ends using the appropriate tool
- ▶ Lubricate the thread of the connection with refrigerant oil
- ⚠ Do not use any other type of lubricant.
- ⚠ The deburring must not have any breaks, cracks, or splintering.
- ⚠ Avoid using refrigerant oil on the outer part of the flare.

To connect:

- ▶ Position the refrigeration lines
- ▶ Manually screw the pipe nut onto the thread of the connection
- ▶ Hold the threaded part of the connection steady with a spanner
- ▶ Use a torque spanner on the nut to tighten it definitively

⚠ Keep the leak detector device on near the unit during the connection process to detect any refrigerant leaks promptly.

⚠ For subsequent operations, refer to the manual of the paired outdoor unit.

Pipe Ø		Tightening torque
mm	inches	Nm
6,35	1/4	18
9,52	3/8	42
12,70	1/2	55
15,88	5/8	60

Outdoor unit solder

- 1. Brazing stub pipe
- 2. External connection pipe
- 3. Adhesive tape

- 4. Tap
- 5. Pressure reducing valve
- 6. Nitrogen tank

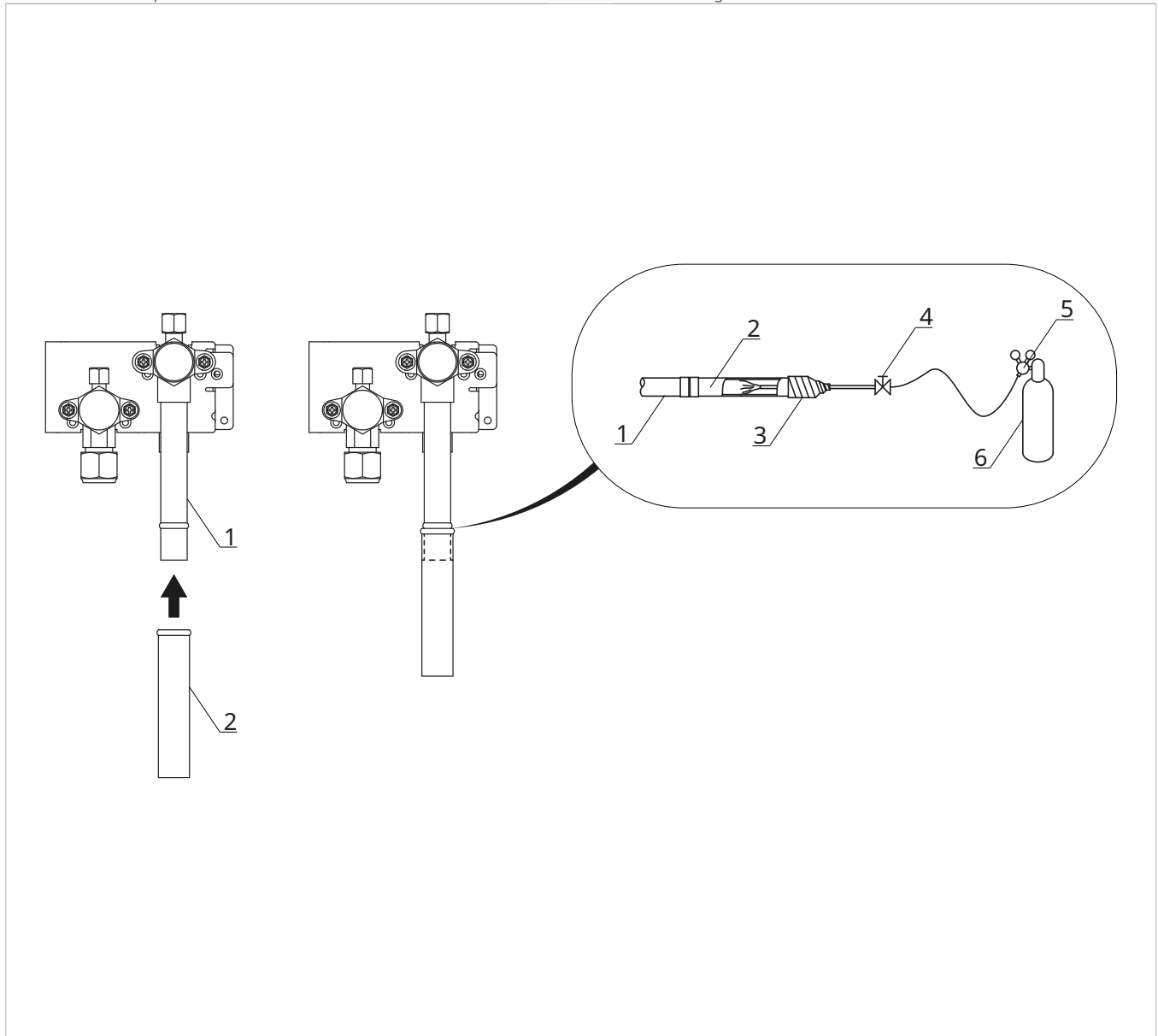

- ⚠ Be sure to replace the air inside the tube with oxygen-free nitrogen to avoid the formation of an oxide film during the brazing operation.
- ⚠ Make sure to use a damp cloth or other means to cool the valve during brazing.

To connect:

- ▶ Bring the pipes closer together
- ▶ Insert the external connecting pipe into the designated stub

- ▶ Perform the brazing
- ⚠ Make sure the tube is securely fastened to the ring and that the entire system is properly aligned.
- ⚠ Make sure to use oxygen free nitrogen. The use of oxygen, CO₂, and CFCs is not allowed
- ⚠ Use a pressure reducing valve on the nitrogen tank.
- ⚠ Do not use agents intended to prevent the formation of oxide films. They will negatively affect the refrigerant oil and may cause equipment failure.

3.12 Condensate drain connection

This appliance comes with a tray to collect the condensation produced during operation. The condensation must be directed to a suitable discharge point.

Preliminary warnings

- ⚠ If the drainage line runs into a container (tank or other) it must be ensured that the container itself is hermet-

ically sealed and most importantly it must be ensured that the drainage pipe is not immersed in water.

- ⚠ The hole for the condensate pipe must always have a downwards slope.
- ⚠ The precise position where the tube inlet should be placed concerning the machine is specified on the drilling template.
- ⚠ Pay attention in this case to ensure that the expelled water does not cause any damage or inconvenience to objects or people. During the winter period, this water could lead to ice formations outside.
- ⚠ When connecting the condensate drain, take care not to crush the rubber pipe.
- ⚠ If necessary, you can empty the condensate collection tray through a safety drain provided on the unit's base.
- ⚠ If an external drainage pipe in "cooling-only" mode is not utilised, it is advisable to plug the condensate drain.

Attachment position

The size and position of the condensate drain attachments are shown below.

1. Condensate drain connection $\varnothing 30$

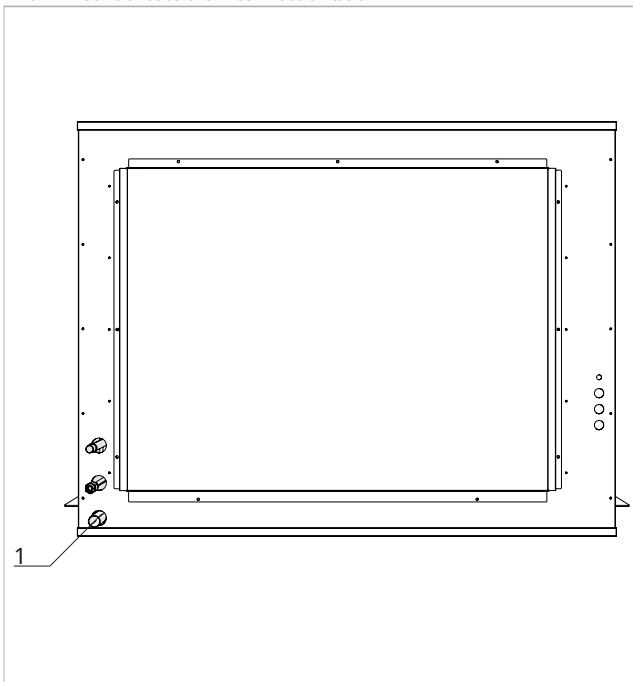

Connections

1. Unit

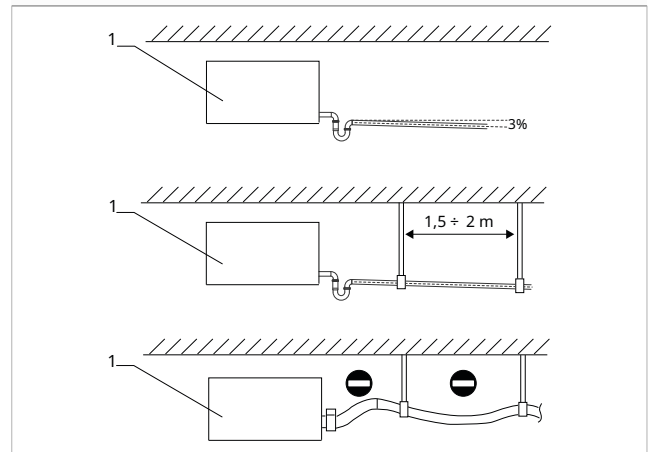

- ▶ Connect the drain pipes to the dedicated connection on the unit
- ▶ Insert a trap for each pipe near the unit
- ⚠ If the drainage pipes are connected into a single pipe, install the siphons before the connection point.
- ▶ Direct the drain pipes towards a suitable discharge location
- ▶ Maintain a minimum slope of 3% towards the discharge location
- ▶ Insulate the joint points
- ⚠ **It is mandatory to install an adequate siphon on the condensate drainage pipe to prevent the negative pressure generated by the fans from obstructing the proper flow of condensate, which could lead to spillage inside the premises.**
- ⚠ The drainage system must include a suitable siphon to prevent unwanted air from entering the vacuum system. The siphon also prevents the entry of odours or insects.
- ⚠ The siphon must be fitted with a plug at the bottom or must in any case permit quick dismantling for cleaning.
- ⚠ Use plastic drainage pipes.
- ⚠ Avoid metal pipes.
- ⚠ Make sure all joints are sealed to prevent leakage of water.
- ⚠ Condensate drain pipes must be insulated for both indoor and outdoor sections to avoid condensation on the surface and/or frosting problems. The insulation must be inserted all the way to the condensate drain pipe connection on the unit.

3.13 Aeraulic connections

Below are the accessories available for ducting the unit.

1. Duct grille for air supply
2. Ducted version (P type)
3. Rear air intake module
4. Ground air intake module

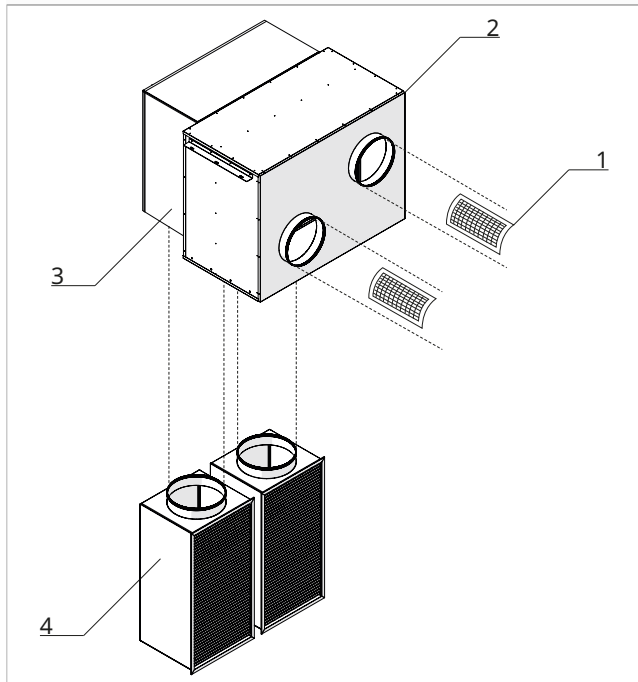

⚠ For the assembly of accessories, refer to the respective instruction sheet.

Preliminary warnings

- ⚠ The sizing of ducting and supply and extract grilles must be carried out by a professionally qualified person.
- ⚠ To prevent the transmission of any vibrations of the machine into the room, an anti-vibration joint should be placed between the fan outlets and the ducts.
- ⚠ The connecting pipes must be of a suitable diameter and supported so that their weight does not put strain on the appliance.

Connections

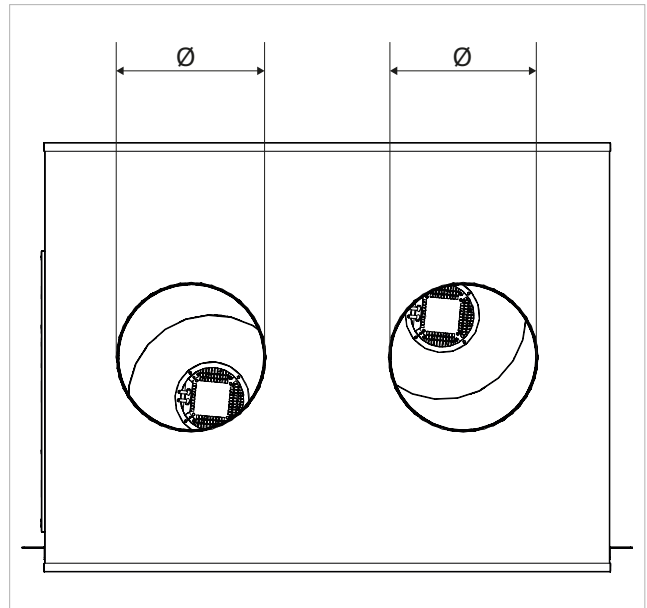

Models	u.m.	P-VTVF140xC5A-PE	P-VTVF250xC5A-PE
Connections			
Air connections (Ø)	mm	355	355
No. of connections		1	2

Circular connections

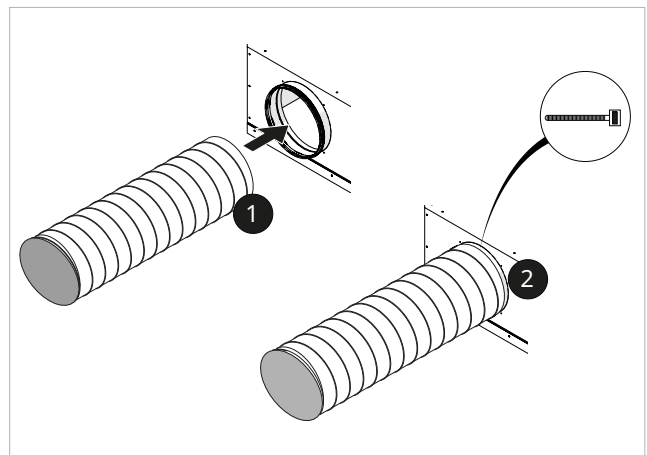

- ▶ Position the ducts on the connections provided on the appliance
- ▶ Use a metal clamp or a duct fixing collar
- ▶ Fix the ducts to the connections
- ⚠ Use ducts lined with anti-condensation material of a suitable thickness.

3.14 Electrical connections

The appliance leaves the factory fully internally wired and only requires connection to the power supply, the associated external unit, and any accessories.

Preliminary warnings

- ⚠ All operations of an electrical nature must be carried out by suitably qualified personnel having the necessary legal knowledge and informed about the risks related to such operations.
- ⚠ All connections must be made in accordance with the relevant regulations in force in the country of installation.
- ⚠ Before carrying out any work, make sure that the power supply is switched off.
- ⚠ The unit should only be powered after the refrigerant, hydraulic and electrical work has been completed.
- ⚠ References:
 - for electrical connections please refer to the wiring diagrams in this manual, especially for the part concerning the power terminal board
- ⚠ Check that:
 - the main supply characteristics are adequate for the power consumption of the appliance, also taking into account any other machinery in parallel operation
 - the power supply voltage and frequency correspond to those specified on the nameplate of the appliance
 - the cables are suitable for installation in accordance with the IEC standards in force
 - the power supply is adequately protected against overloads and/or short circuits
 - the disconnection device is positioned in an easily accessible place to enable intervention in the event of an emergency
- ⚠ It is mandatory:
 - to connect the appliance to an effective grounding system
 - for units with three-phase power supply, check the correct phase connection
 - provide an all-pole switch with a contact opening distance of at least 3 mm that allows complete disconnection under overvoltage category III conditions
 - Install a ground fault circuit interrupter (GFCI). Failure to install this device could result in electric shock
- ⚠ Ensure that a connection to earth is made. Do not ground the appliance to distribution pipes, surge arresters or the ground of telephony systems. If not performed correctly, grounding can cause an electric shock. Momentary high voltage surges caused by lightning or other causes could damage the heat pump.
- ⚠ Ensure that a connection to earth is made. Do not ground the appliance to distribution pipes, surge arresters or the ground of telephony systems. If not performed correctly, grounding can cause an electric shock. Momentary high voltage surges caused by lightning or other causes could damage the heat pump.
- ⚠ Use a dedicated power supply circuit. Never use a power supply to which another appliance is also connected due to risk of overheating, electric shock or fire.

- ⚠ For the electrical connection, use a cable of sufficient length to cover the entire distance without any connection. Do not use extension cables. Do not apply other loads on the power supply.
- ⚠ After connecting the interconnection and power supply cables, ensure that the cables are arranged so that they do not exert excessive forces on the covers or electrical panels. Install the covers on the cables. Incomplete connections of the covers can lead to overheating of the terminals, electric shock or fire.
- ⚠ Any replacement of the power cable must only be carried out by qualified personnel and in accordance with current national regulations.
- ⚠ The Manufacturer is not liable for any damage caused by the lack of earthing or failure to comply with the specifications in the respective diagrams.
- ⚠ The appliance is equipped with a noise filter as required by current regulations. Use selective residual current circuit breakers to compensate for the micro leakage to earth of this device.
- ⊖ Using gas and water pipes to ground the appliance is prohibited.

Preliminary warnings for R32

- ⚠ The R32 refrigerant gas is mildly flammable and odourless.
- ⚠ All precautions regarding the handling of refrigerant must be followed in accordance with current regulations.
- ⚠ Avoid proximity to continuously operating ignition sources (open flames, gas appliances, electric stoves, lit cigarettes, etc.).
- ⊖ Smoking is prohibited near the appliance.
- ⊖ The use of mobile phones is prohibited near the appliance.
- ⚠ Perform the following checks:
 - Perform safety checks to ensure that the risk of combustion is minimised
 - avoid working in confined spaces
 - delimit the area around the workspace
 - ensure safe working conditions around the area by checking for flammable materials

Power line dimensioning

Use the tables below for the sizing of the power supply line and its protection device.

These are not average draw or transient peaks, but values to be considered for the correct sizing of the plant and the request of the contractual power (excluding loads due to the normal operation of the building).

- ⚠ Maximum power is reached only in exceptional cases. Therefore, the indicated trip current is suggested to guarantee a balance between machine absorption and incidence in the general system.
- ⚠ The indicated minimum cable cross-section area must be verified according to the actual conditions of the installation: length of the cable, characteristics of the electrical supply, etc.

Access to the electrical panel

- ⚠ Access to the electrical panel is only permitted to qualified personnel.
- ⚠ Before carrying out any work, ensure that the power supply is switched off.

1. Electrical connections passthrough

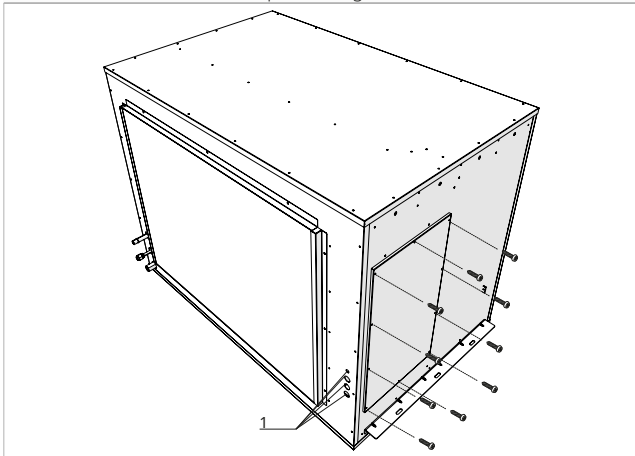

To access the connections:

- ▶ Undo the fixing screws
- ▶ Remove the cover of the electrical panel

Connections

Before connecting the unit to the mains power supply, make sure that the isolator is open. The power supply of the unit (single phase or three phase) must be connected to the appropriate terminals, subjected to the action of the isolating switch.

- ⚠ Use properly sized cables to avoid voltage drops or overheating.
- ⚠ Use a cable with a minimum cross-section of 1.5 mm² and adequate insulation to ensure a secure seal in the cable glands.
- ⚠ Before making the connection to the terminals, carefully read the information provided in this manual.

Connection diagram

- 1. Unit
- 2. Remote control (example only)
- 3. Wired controller communication cable
- 4. Communication and power cable

- 5. Outdoor unit
- 6. Isolator
- 7. Electrical supply 230/1/50 or 400/3/50 depending on the model

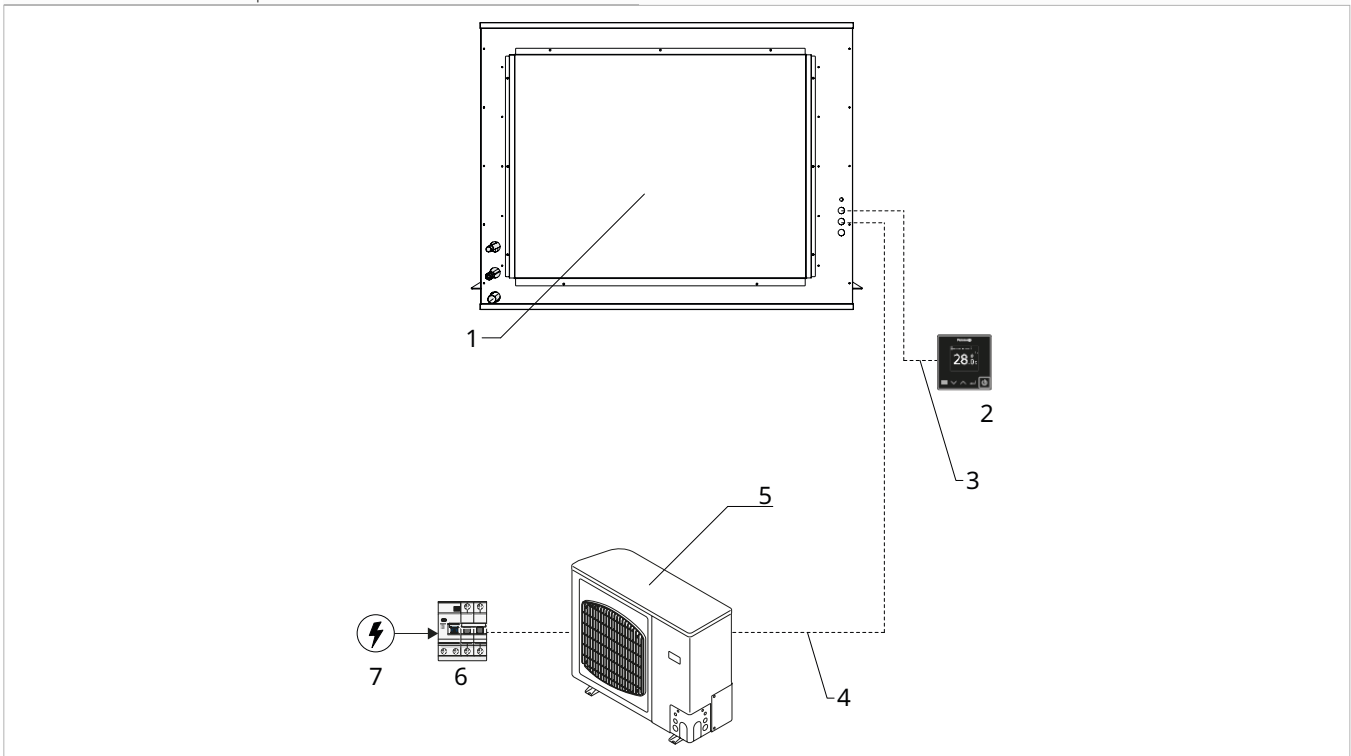

On-board electrical panel

Connection terminal board

A Connection between outdoor and indoor unit
B Panasonic central control connection

C Wired remote control display connection

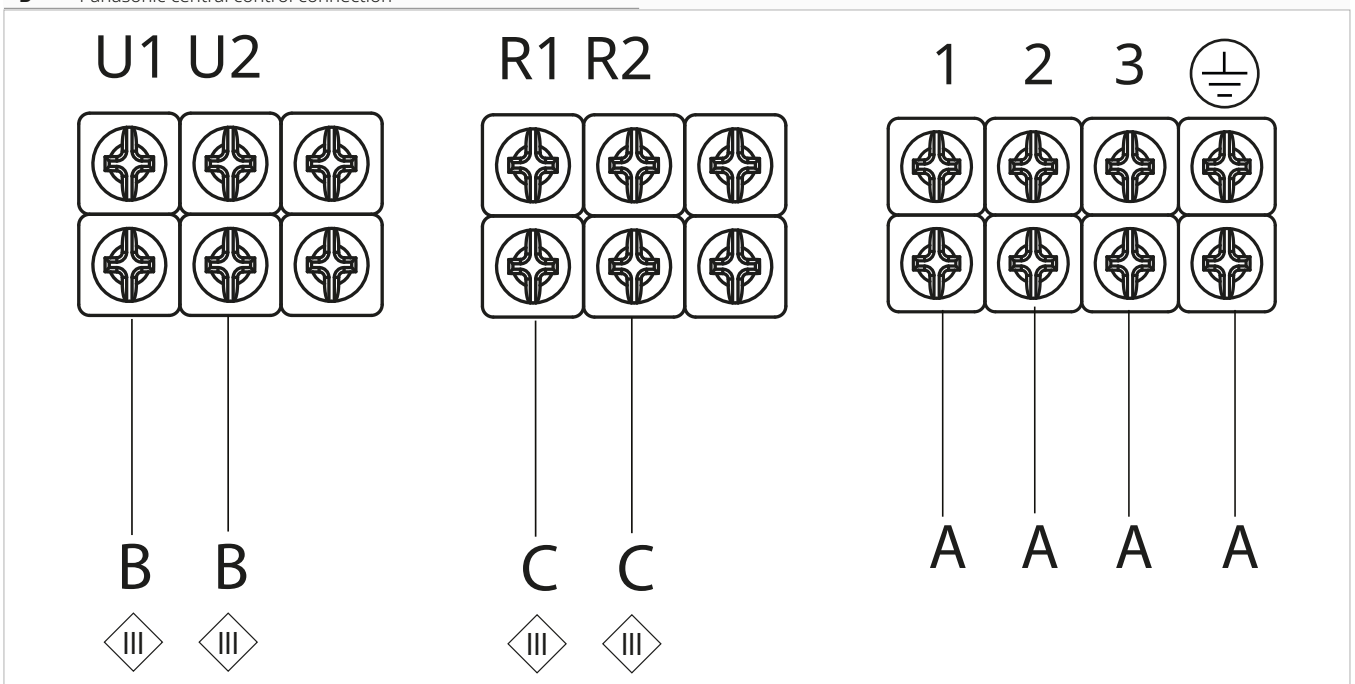

External unit connection

The external unit is controlled through 3 wires with 230V voltage and the earth connection:

1. Live
2. Neutral
3. Comm

 Earth

1. External unit communication

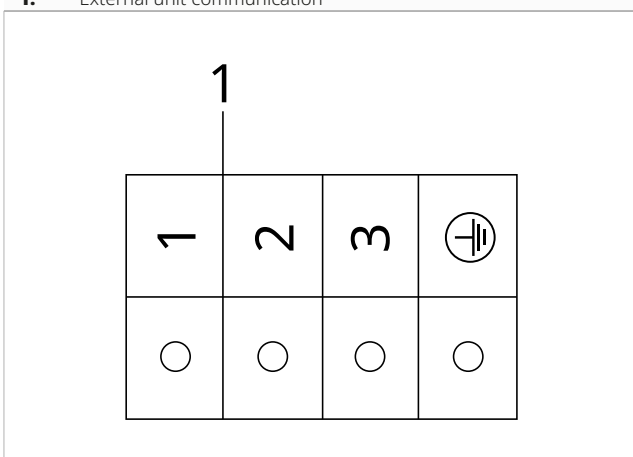

 Follow sequence 1, 2 and 3

Connections

Multiple connection

The unit is designed to connect multiple devices under the same command.

⚠ One controller can control a maximum of 8 devices.

Display connection

Connect the control panel to the terminal block provided on the unit.

A multiple connection type is provided:

- Wired connection

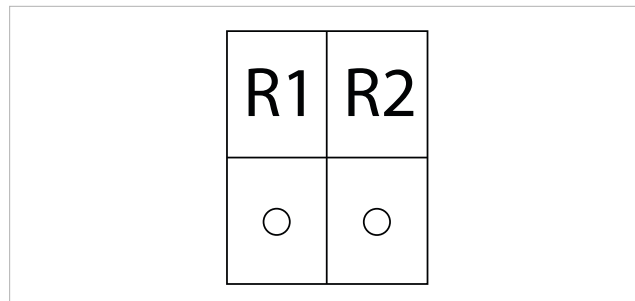

Multiple wired connection

The network is serial with serial connection.

- R1
- R2

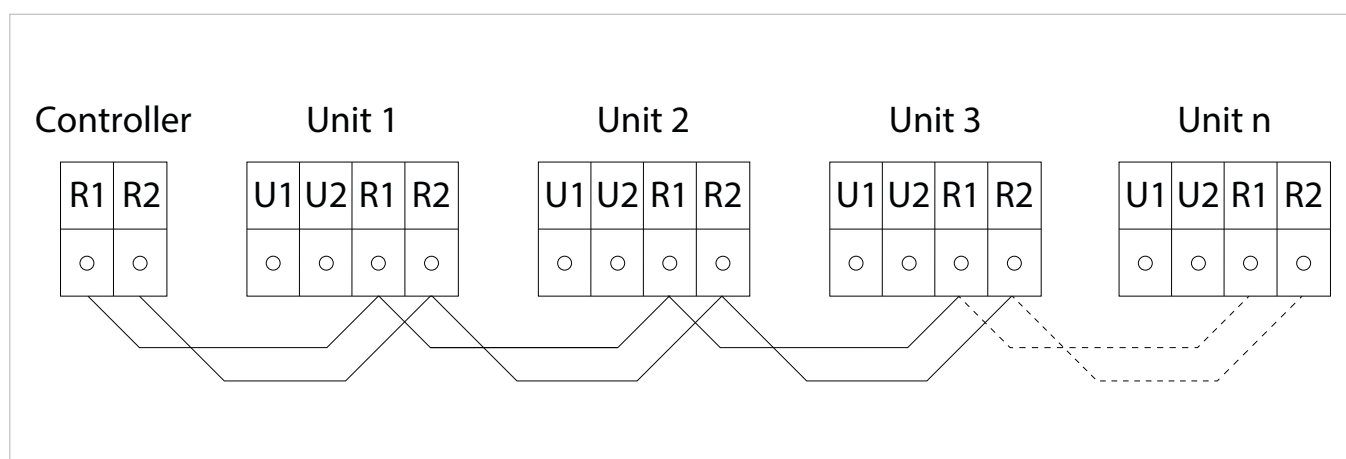
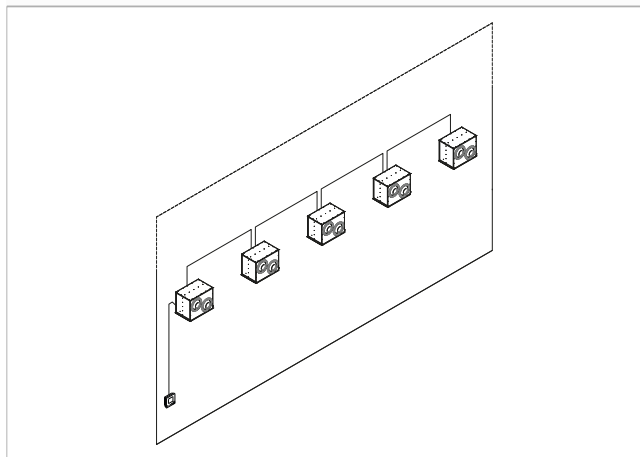

Panasonic central control connection

The network is serial with serial connection.

For details regarding connection to centralized control, refer to the centralized control documentation.

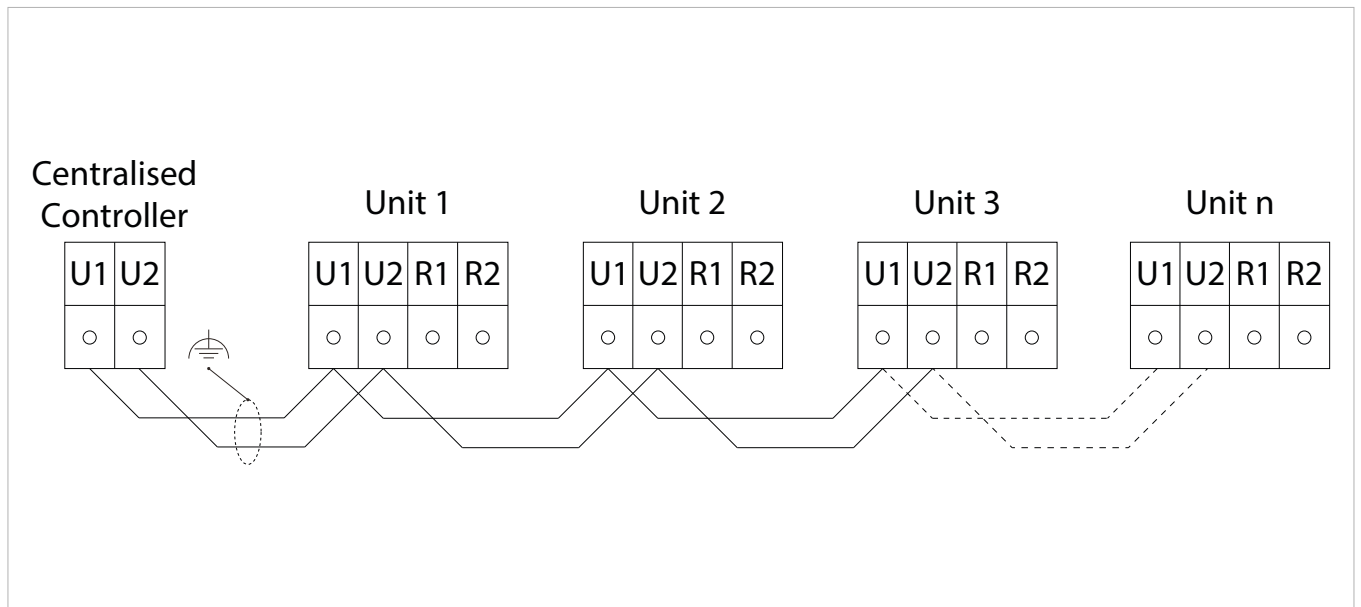
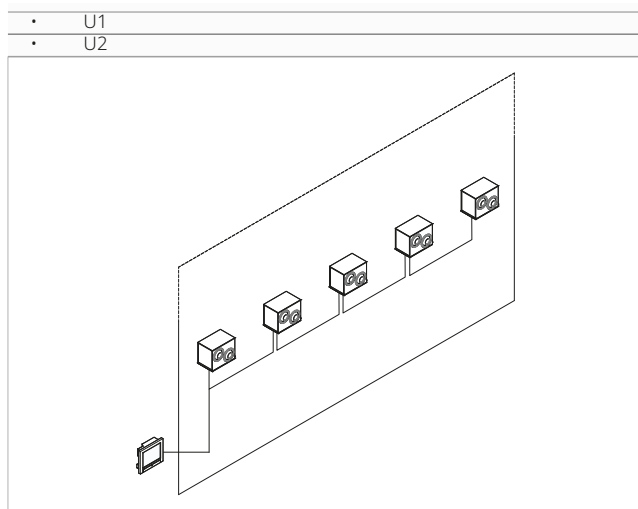

4. START-UP

4.1 Preliminary warnings

⚠ **This section is dedicated to the Authorised Service Centre. The specifications of the Authorised Service Centre are described in chapter "Recipients" p. 4.**

⚠ **Initial commissioning must be carried out by the Authorised Service Centre.**

⚠ **For detailed information on accessories, please refer to the relevant instruction sheets.**

See chapter "Compatible accessories" p. 12

⚠ The customer must be present when testing the device and be informed of the contents of the manual and procedures. After commissioning, the manual must be delivered to the customer.

⚠ Before start-up, all works (electrical, refrigerant, hydraulic and airflow connections) must have been completed.

Preliminary warnings for R32

⚠ The unit uses R32 refrigerant, with a Global Warming Potential (GWP) of 675. Do not release R32 gas into the atmosphere.

⚠ The R32 refrigerant gas is mildly flammable and odourless.

⚠ All precautions regarding the handling of refrigerant must be followed in accordance with current regulations.

⚠ Avoid proximity to continuously operating ignition sources (open flames, gas appliances, electric stoves, lit cigarettes, etc.).

⊖ It is prohibited to use means to speed up the defrosting process or for cleaning other than those recommended.

⊖ Smoking is prohibited near the appliance.

⊖ The use of mobile phones is prohibited near the appliance.

⊖ It is forbidden to introduce objects and substances through the openings provided for the intake and delivery of air.

⚠ Perform the following checks:

- Perform safety checks to ensure that the risk of combustion is minimised
- avoid working in confined spaces
- delimit the area around the workspace
- ensure safe working conditions around the area by checking for flammable materials

Leak detection

⊖ Using combustion-based refrigerant fluid detectors, such as a halide torch or any other system using an open flame, is prohibited.

⚠ For leak detection, follow the following instructions:

- use electronic detectors to search for flammable refrigerant fluids
- before usage, ensure the detectors are properly calibrated
- calibration operations must be carried out in an area free from refrigerant fluid
- ensure the detector is not a potential ignition source and is suitable for the refrigerant fluid used
- if a leak is suspected, all open flames must be eliminated
- in the event of a leak requiring brazing, it is mandatory to recover all refrigerant fluid from the system or isolate it (using shut-off valves) in a part of the system away from the leak

⚠ The use of silicone sealant can compromise the effectiveness of certain types of leak detection instruments.

4.2 First start-up

Preliminary Checks

Before commissioning, check that:

Operational checks

- all safety conditions have been met
- the unit has been properly secured to the supporting surface or wall
- the minimum technical spaces have been observed

Electrical checks

- the cross-section of the power supply cables is adequate for the absorption of the appliance and the length of the connection made

- grounding is correctly performed
- the electrical connections have been established correctly
- all electrical connections are properly secured and all terminals are adequately tightened
- the voltage is within a tolerance of 10% compared to the unit's nominal voltage
- the power supply for the three-phase models has a maximum phase imbalance of 3%
- all control wires are connected and that all electrical connections are secure

Refrigerators

- the refrigerant connections have been made following the instructions provided in the manual
- the shut-off valves of the refrigeration circuit are open

Powering up

⚠ **Before starting, power up the unit for at least 12 hours.**

⚠ Make sure that the control panel is switched off.

To power up the unit:

- ▶ Set the main switch to ON

The display will light up a few seconds after powering up. Check that the operating status is OFF.

⚠ **For performing operations, refer to the Control Panel Manual.**

Start-up

After all checks have been carried out, the unit can be put into operation.

To activate the appliance:

- ▶ Refer to the user manual

- ▶ Check that when power supply is lost and restarted, the unit returns to the previous operation

Checks with the machine switched on

After starting up, check the following:

Operational checks:

- verify the different modes of operation
- verify that the appliance stops and then restarts
- switch the appliance off and on again and check that it restarts correctly
- the appliance operates within the recommended operating conditions (see technical specifications table)
- check that the air flow rates are correct

Hydraulic Checks

- check for proper condensate drainage

Electrical Checks

- the current absorbed is less than the maximum indicated in the technical data table
- the supply voltage value is within the set limits and does not fall below the nominal value -10 % during operation

4.3 Plant delivery

Once all the checks and controls on the correct operation of the plant have been completed, the installer must explain the following to the user:

- the basic functional characteristics of the appliance
- the instructions for use
- the routine maintenance

4.4 Switching off for extended periods

If the appliance is not used for a long period of time, the following steps must be taken:

- ▶ Deactivating the appliance

- ▶ Isolate the power supply

⚠ To restart the appliance after it has been out of use for a long period, call in the Authorised Service Centre.

4.5 To adjust the fan static pressure

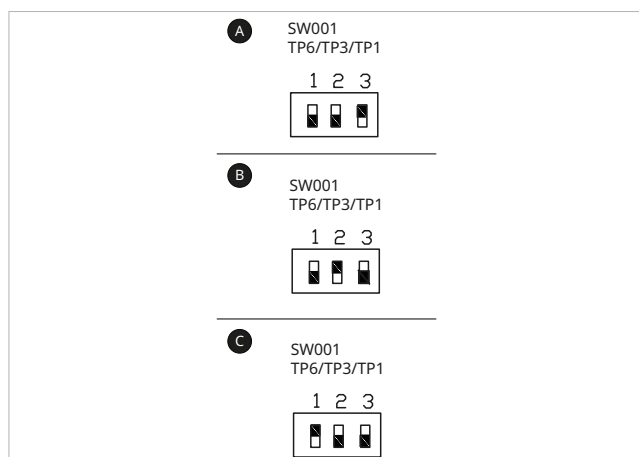

There are 3 possible static pressure configurations; each configuration is activated by a single ON switch, listed below:

- Configuration A: Switch 3 ON (1 and 2 OFF), selects the fan speed for low static pressure (low head) for the version with nozzles
- Configuration B: Switch 2 ON (1 and 3 OFF), selects the fan speed for medium static pressure (medium head) for the ducted version
- Configuration C: Switch 1 ON (2 and 3 OFF), selects the fan speed for high static pressure (high head) for the ducted version.

⚠ The switches are in the ON position when the switch is moved upward

5. CONTROL CONFIGURATIONS

5.1 Automatic addressing procedure

Single unit system

- | | |
|----|---|
| 1. | Outdoor unit |
| 2. | Connection cable between outdoor unit and indoor unit |
| 3. | Remote controller |
| 4. | Remote control wiring |
| 5. | Indoor unit |

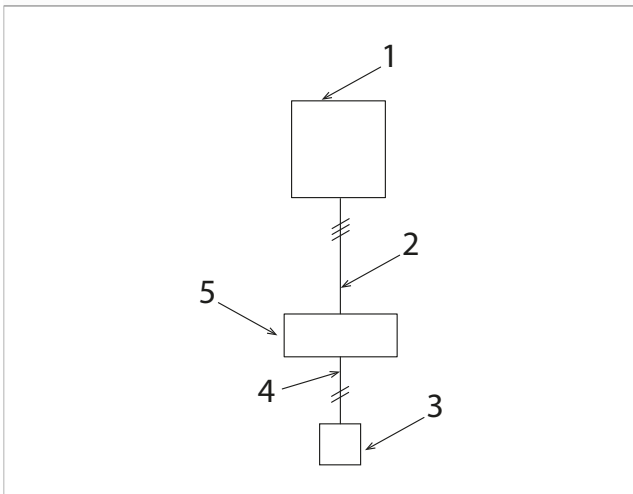

- Check that the combination of external and indoor unit is correct.
- Ensure that all wiring and refrigerant connections have been carried out correctly and that the refrigerant shut-off valves are open before addressing.
- ⊖ Never switch on the external unit before installation is completed.
- Switch on the unit for at least 12 hours before switching it on.
- Switch on the external and indoor units. Automatic addressing should start automatically when the system is switched on.
- Completion of the automatic addressing will take about 10 minutes.
- After completing the automatic addressing setup, wait about 2 minutes, then start the test run.

Multiple unit system

- Check that the combination of external and indoor unit is correct.
- Ensure that all wiring and refrigerant connections have been carried out correctly and that the refrigerant shut-off valves are open before addressing.
- ⊖ Never switch on the unit before installation is completed.
- Switch on the external units for at least 12 hours before switching them on.
- Automatic addressing of each refrigerant system must be carried out in sequence. Switch on each refrigerant system one at a time.
- Switch on the external and indoor units of refrigerant system 1. Automatic addressing should start automatically when the system is switched on.
- Completion of the automatic addressing setup will take about 10 minutes.
- Proceed with switching on the next refrigerant system, waiting for the next system to complete the automatic addressing procedure.
- Repeat the procedure for all systems within the same local control network.

- Once the automatic addressing setup is complete for all refrigerant systems, wait about 2 minutes, then start the test run.

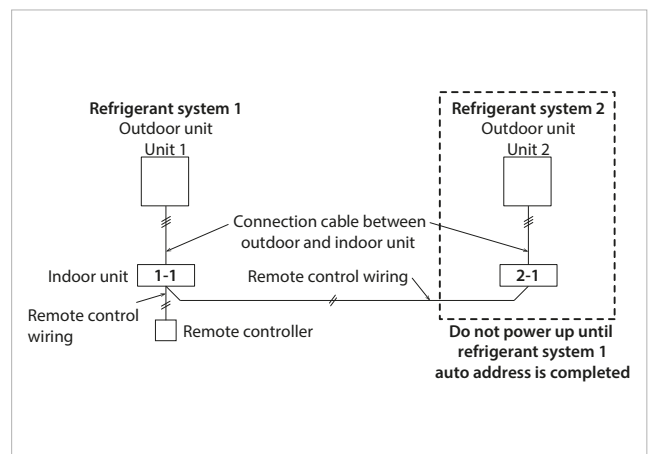

5.2 Automatic address setting via remote controller

Procedure for CZ-RTC6 controller

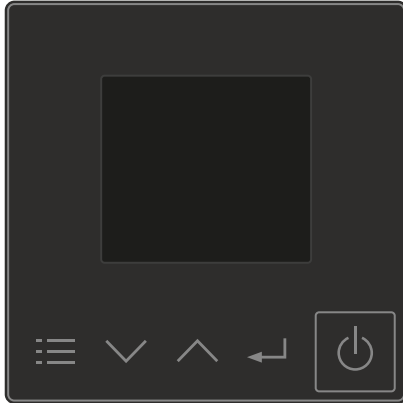

- ▶ Press the and buttons simultaneously for at least 4 seconds.
The "Maintenance func" screen is displayed on the LCD display

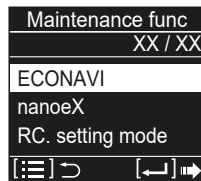

- ▶ Press the or button to display each menu
- ▶ Select "Auto address"

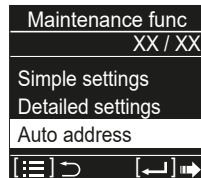

- ▶ Press the button
The "Auto address" screen appears on the LCD display



- ▶ Press the or button
- ▶ Select "Code no." to "A1"
After selecting "Code no."
At this point two alternatives are possible by pressing the button or the button

Alternative 1

- ▶ Press the button
- ▶ Press the or button
- ▶ Select one of the "O/D unit no." for automatic addressing

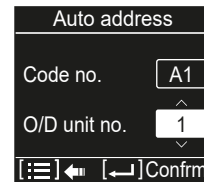

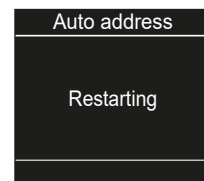
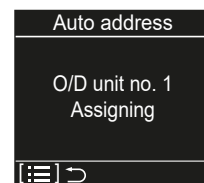
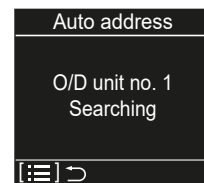

- ▶ Press the button
The addressing procedure starts (duration approx. 10 minutes)





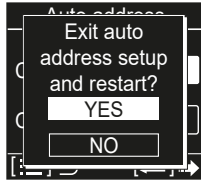

At the end of the procedure the unit returns to stop status.

Alternative 2

- ▶ Press the  button
- ▶ The "Auto address" screen appears on the display
- ▶ Press the  or  button
- ▶ Select "YES"





- ▶ Press the  button



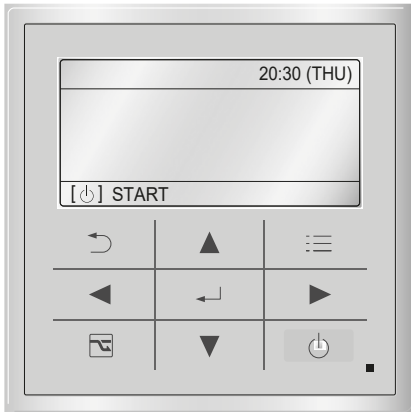

- ▶ Change "Code no." to "A1"
- ▶ Press the  or  button
- ▶ Select "O/D unit no."
- ▶ Press the  or  button
- ▶ Select "O/D unit no."
- ▶ Press 
 - The addressing procedure starts (duration approx. 10 minutes)*
 - At the end of the procedure the unit returns to stop status.*

Procedure for CZ-RTC5B controller

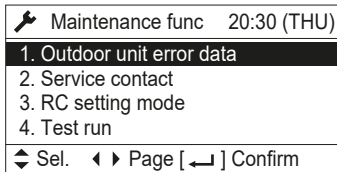

- ▶ Press the  ,  and  buttons simultaneously for at least 4 seconds.
- ▶ The "Maintenance func" screen is displayed on the LCD display



- ▶ Press the  or  button to display each menu
- ▶ Press the  or  button to display the next screen immediately
- ▶ Select "9 Auto address"

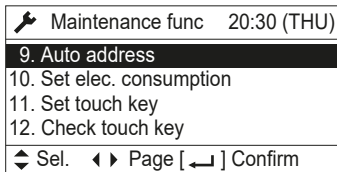

- ▶ Press the  button
The "Auto address" screen appears on the display
- ▶ Press the  or  button

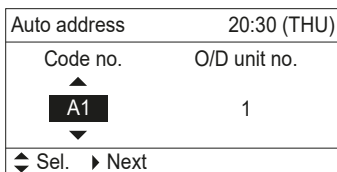

5.3 How to check detailed settings 11, 12, 13 and 14

The detailed settings below may need to be checked in the event of a capacity setting error, or if system, local and group addressing must be adjusted manually if automatic addressing is not completed correctly.

The relevant detailed setting codes are as follows:

Code no.	Item
11	Indoor unit capacity
12	System address
13	Indoor unit address
14	Group control address

Capacity setting

⚠ Refer to the table below to confirm the capacity code for the respective models. An incorrect capacity setting will result in an error (error codes E15, E16 or L09).

Code no.	Model	
	140	250
11	0018	0023

Refrigerant system addressing

Each refrigerant system must have a system address. In a single installation, these can be the same, but in an installation with multiple systems within the same control group or when connected to a centralised control network, each system must have a unique system address.

Since the units are installed with one indoor unit connected to one external unit, the indoor unit address can be the same.

The following table defines the system address requirements for connecting multiple indoor units.

This should be automatically assigned when using the auto-addressing feature.

If problems occur during the automatic addressing procedure, check that the following is assigned correctly to each connected system and the respective indoor unit.

Code no.	Refrigerant System			
	Unit 1	Unit 2	Unit 3	Unit n
12	0001	0002	0003	000x
13	0001	0001	0001	0001

⚠ Up to 8 units can be connected within the same local control group

Local group control setting

When connecting multiple indoor units, assignment of the MAIN and SUB indoor units should be carried out automatically.

⚠ If problems occur during the automatic addressing procedure (error code E14), ensure that the following settings are applied to the indoor units to guarantee correct operation.

Code no.	Group control setting			
	Main	Sub 1	Sub 2	Sub n
14	0001	0002	0002	0002

⚠ Up to 8 units can be connected within the same local control group

5.4 How to adjust detailed settings using the remote controller

Procedure for CZ-RTC6 controller

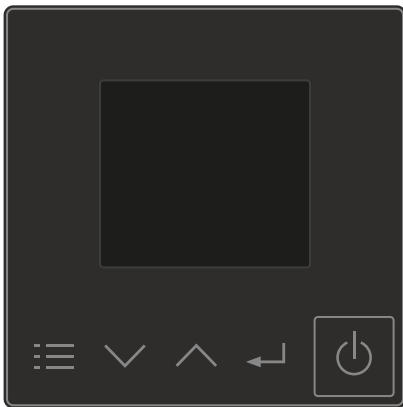

- ▶ Press the , and buttons simultaneously for at least 4 seconds.
The "Maintenance func" screen is displayed on the LCD display

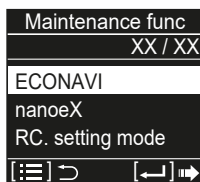

- ▶ Press the or button to display each menu
- ▶ Select "Detailed settings" on the LCD display

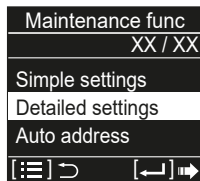

- ▶ Press the button
- ▶ Press the or button to select "Unit no."
- ▶ Press the button

⚠ If the address setting is not correct, "ALL" will be displayed in the "Unit n." field.

At this point two alternatives are possible by pressing the button or the button

Alternative 1

- ▶ Press and hold the button for 2 seconds while selecting "Code no."



Change the "Code no." one digit at a time so that it becomes [0000XX] by following the procedures below:

- ▶ Press the or button to change the value
After changing the value

- ▶ Press the or button and set the next digit

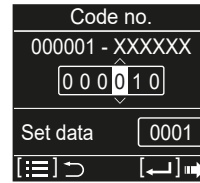

FIGURE A

After changing the value

- ▶ Press the button and set the next digit
- ▶ Press the or button to change the value

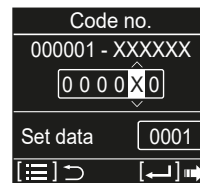

FIGURE B

After changing the value

- ▶ Press the button and set the next digit
- ▶ Press the or button to change the value

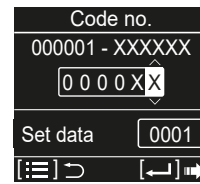
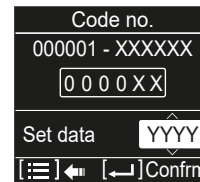

FIGURE C

After changing the value

- ▶ Press the button
- ▶ Press the or button to select one of the setting data "YYYY"



- ▶ Select "Set data"
- ▶ Press the button

If you want to make a continuous setting, follow the procedures in Fig. A.

If you want to change the selected indoor unit or finish the setting, follow the next step:

- ▶ Press the button twice
The display returns to the initial step

Alternative 2

- ▶ Press the button
The "Detailed setting-end screen" is displayed

- ▶ Press the or button
- ▶ Select "YES"

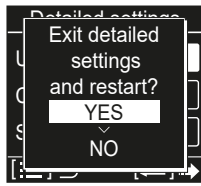

- ▶ Press the button
Return to the normal remote controller display

Procedure for CZ-RTC5B controller

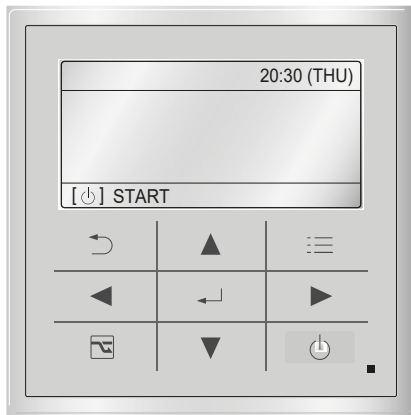

Press the , , and buttons simultaneously for at least 4 seconds.

- ▶ Display "Maintenance func" on the LCD display.

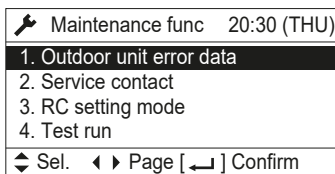

- ▶ Press the or button to display each menu
- ▶ Press or to display the next screen immediately
- ▶ Select "8. Detailed settings" on the LCD display

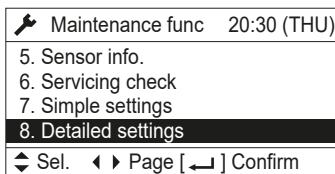

- ▶ Press the button
The "Detailed settings" screen is displayed on the LCD display
- ▶ Press the or button to select and change "Unit no."

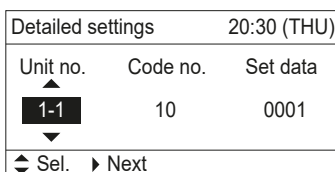

- ⚠ If the address setting is not correct, "ALL" is displayed in the "Unit no." field

- ▶ Press the or button to select "Code no."

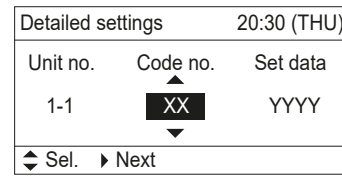

- ▶ Press the or button to change "Code no." to "XX"
- ▶ Press the or button to select "Set data"

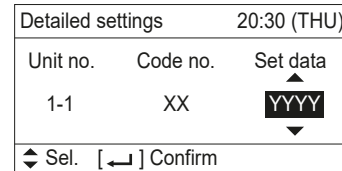

- ▶ Press the or button to select one of the setting data "YYYYY"
- ▶ Press the button

If you want to change the selected indoor unit, follow the step below:

- ▶ Press the or button to select "Unit no." and make changes

- ⚠ If the address setting is not correct, "ALL" is displayed in the "Unit no." field

If you do not want to change any data, proceed as follows:

- ▶ Press the button
The "Exit detailed settings and restart?" screen is displayed on the LCD display (end of detailed settings)
- ▶ Press the or button
- ▶ Select "YES"

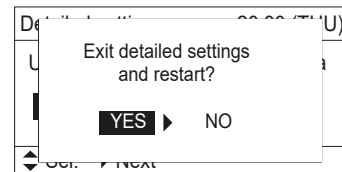

- ▶ Press the button
Return to the normal remote controller display

5.5 Test run using the remote controller

Procedure for CZ-RTC6 controller

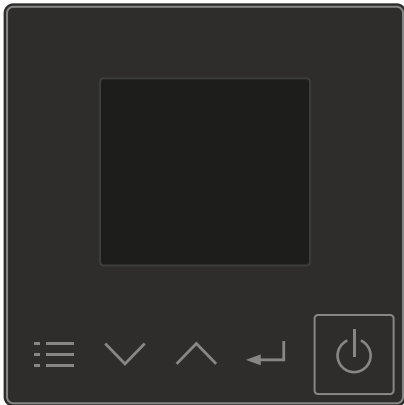

▶ Press the , and buttons simultaneously for at least 4 seconds.
The "Maintenance func" screen is displayed on the LCD display

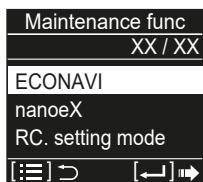

▶ Press the or button to display each menu
▶ Select "Test Run" on the LCD display

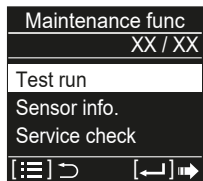

▶ Press the button
▶ Press the or button to change the display from "OFF" to "ON"

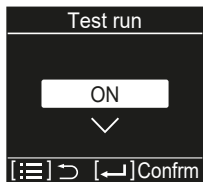

▶ Press the button
▶ Press the button
"TEST" is displayed on the LCD display

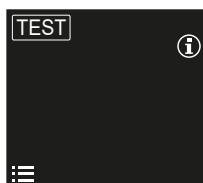

▶ Press the button
The test run starts

The test run setting mode screen is displayed on the LCD display.

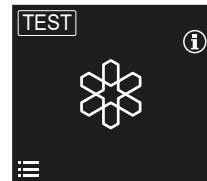

- The test run can be performed in HEATING, COOLING or VENTILATION mode
- Temperature cannot be adjusted in test run mode
- If correct operation is not possible, a code will be displayed on the remote controller LCD display
 - ⚠ To view the alarm content, refer to the "Failures and remedies" section.
 - After completing the test, proceed from the initial step and switch to "OFF" at the next step.
 - ⚠ To prevent the test from being performed continuously, this remote controller includes a timer function that cancels the test after 60 minutes.
 - ⚠ The external units will not operate for about 3 minutes after start-up and stop of operation

Procedure for CZ-RTC5B controller

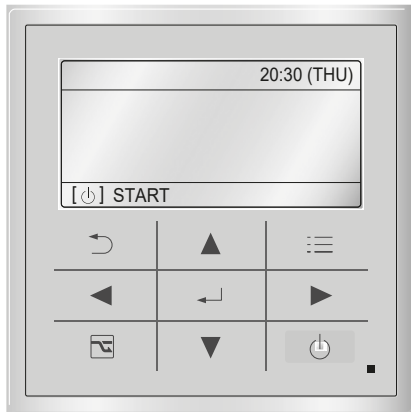

- ▶ Press the , and buttons simultaneously for at least 4 seconds.
- ▶ Display "Maintenance func" on the LCD display.

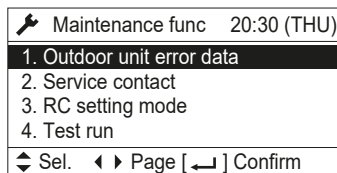

- ▶ Press the or button to display each menu
- ▶ Press or to display the next screen immediately
- ▶ Press the or button
- ▶ Select "4 Test run" on the LCD display

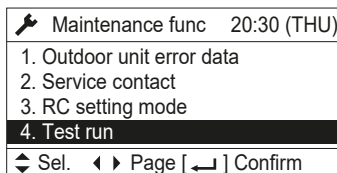

- ▶ Press the or button to change the display from "OFF" to "ON"

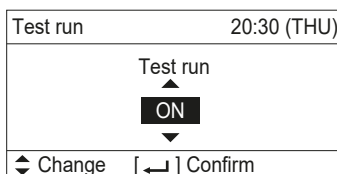

- ▶ Press the button
- ▶ Press the button
"TEST" is displayed on the display

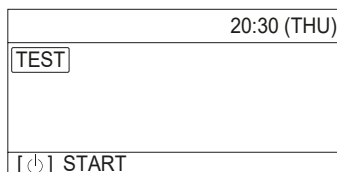

- ▶ Press the button
The test run starts
The test run setting mode screen is displayed on the LCD display.

- The test run can be performed in HEATING, COOLING or VENTILATION mode

- Temperature cannot be adjusted in test run mode
- If correct operation is not possible, a code will be displayed on the remote controller LCD display
- ⚠ To view the alarm content, refer to the "Failures and remedies" section.
After completing the test, proceed from the initial step and switch to "OFF" at the next step.
- ⚠ To prevent the test from being performed continuously, this remote controller includes a timer function that cancels the test after 60 minutes.
- ⚠ The external units will not operate for about 3 minutes after start-up and stop of operation

5.6 Main/sub remote controller setting

Up to 2 remote controllers can be connected within the same local control group. To allow more than one controller, the main and sub remote controller must be set accordingly.

The table below defines the RC. Setting Mode setting for each controller within the group. If this setting is not correct, an error will occur (error code E09).

RC. Setting mode	Controller	
	MAIN	SUB
Main/Sub	0001	0000

Procedure for CZ-RTC6 controller

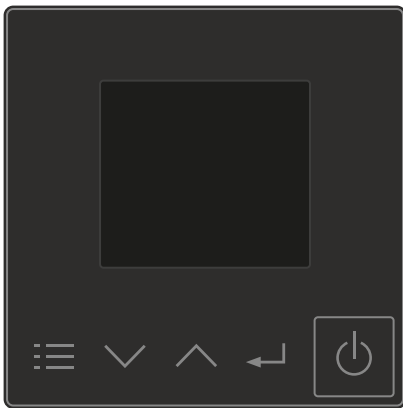

- ▶ Press the , and buttons simultaneously for at least 4 seconds. The "Maintenance func" screen is displayed on the LCD display

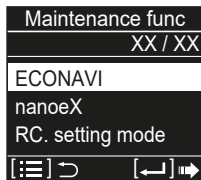

- ▶ Press the or buttons to display each menu
- ▶ Select "RC. setting mode" on the LCD display

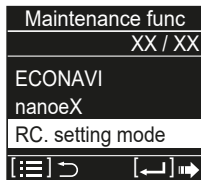

- ▶ Press the button
- ▶ Press the button to select "Code no." Make sure that "01" is displayed for the main/sub setting

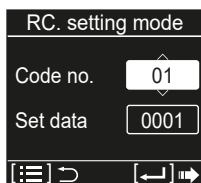

- ▶ Press the button to confirm the selection After selecting "Code no."
- ▶ Press the button
- ▶ Press the or button to change the "Set data" value

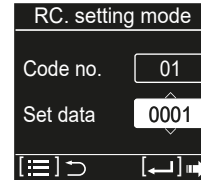

Select "0001" for MAIN or "0000" for SUB.

- ▶ Press the button to confirm
- ▶ Press the button to exit "RC setting mode" The following screen appears

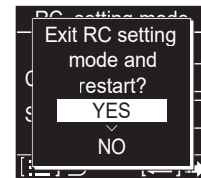

- ▶ Press the button
- ▶ Select "YES"
- ▶ Press the button to confirm The message "Restarting" will briefly appear on the screen before the controller returns to the initial display.

Procedure for CZ-RTC5B controller

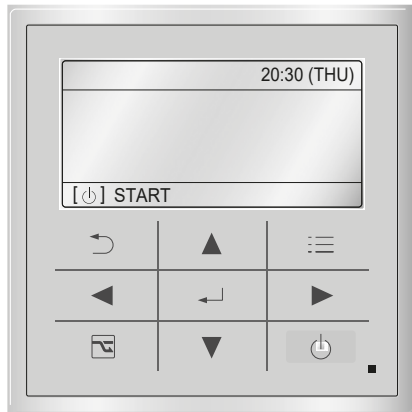

- ▶ Press the , and buttons simultaneously for at least 4 seconds.
- ▶ Display "Maintenance func" on the LCD display.

Maintenance func	20:30 (THU)
1. Outdoor unit error data	
2. Service contact	
3. RC setting mode	
4. Test run	
◆ Sel. ◀ ▶ Page [] Confirm	

- ▶ Press the or button
- ▶ Select "RC. setting mode" on the display

Maintenance func	20:30 (THU)
1. Outdoor unit error data	
2. Service contact	
3. RC. setting mode	
4. Test run	
◆ Sel. ◀ ▶ Page [] Confirm	

- ▶ Press the button
- With "Code no." selected

RC. Setting mode	20:30 (THU)
Code no.	Set data
01	0001
◆ Sel. ▶ Next	

- ▶ Press the or button to change the value to "01" if not indicated
- ▶ Press the button to move to "Set data"

RC. Setting mode	20:30 (THU)
Code no.	Set data
01	0001
◆ Sel. ▶ Next	

- ▶ Press the or button to change the value
- Select "0001" for MAIN or "0000" for SUB

- ▶ Press the button to confirm
 - ▶ Press the button to exit "RC setting mode" mode
- The following screen is displayed

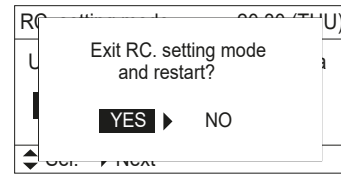

- ▶ Press the button
 - ▶ Select "YES"
- The message "Restarting" will briefly appear on the screen before the controller returns to the initial display.

6. MAINTENANCE

6.1 Routine maintenance

Preliminary warnings

Before any cleaning or maintenance intervention:

- ▶ Disconnect the appliance from the mains by setting the main system switch to "OFF"
- ▶ Wait for the components to cool down to avoid the risk of burns
- ⊖ Any technical or cleaning intervention is prohibited before disconnecting the unit from the power supply.
- ⚠ Check for the absence of voltage before performing any operation.
- ⚠ After performing the necessary maintenance operations, restore the system to the original condition
- ⚠ It is forbidden to introduce objects and substances through the openings provided for the intake and delivery of air.
- ⚠ Handle the refrigerant with care. Leaking refrigerant can cause frostbite.
- ⚠ For safety and installation requirements relating to the outdoor unit and overall system installation, please refer to the relevant outdoor unit documentation.

Annual operations

The annual maintenance plan includes the following operations and checks and must be carried out by the Technical Assistance Centre or qualified personnel.

Electrical circuit

Check:

- electrical supply voltage
- the electrical absorption
- tightening connections
- that there is no damage or excessive wear to electrical cables
- that the gaskets and sealing materials have not deteriorated to such an extent that they are no longer suitable for the purpose of preventing the development of flammable atmospheres inside
- the correct fixing of cable glands
- safety devices

Mechanical checks

Check:

- tightening of the screws, fans and electrical box, of the unit's external panelling
- the state of the structure
- ⚠ Bad fixings result in abnormal noise and vibration.
- ⚠ If oxidised parts are present, treat them with suitable paints to eliminate or reduce oxidation.

Hydraulic controls

Check:

- the regular drainage of condensate
- cleaning the condensate collection trays
- cleaning the exhaust ducts

Airflow controls

Check:

- the regular flow of air
- cleaning of any intake grilles
- cleaning the ducting

Cleaning

- cleaning of aesthetic cover
- cleaning or filter replacement
- cleaning the heat exchanger

Cleaning or filter replacement

To remove:

1. Filter bracket with knob lock
2. Filter

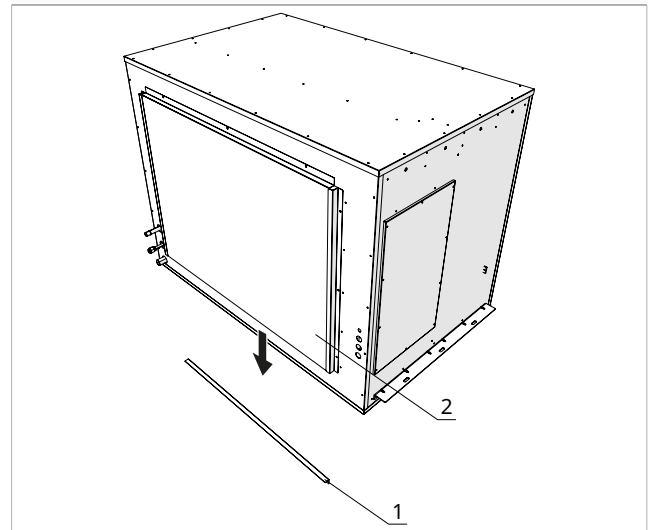

- ▶ Isolate the power supply to the unit
- ▶ Unscrew the knobs
- ▶ Remove the filter bracket
- ▶ Take the filter
- ⚠ Be careful to avoid damaging the filter during its extraction; maintain a firm yet gentle grip on the filter to ensure safe and controlled removal.

- ⚠ Pay attention to sharp surfaces
- ① **If the condition of the filters is acceptable, they can be cleaned using a vacuum cleaner or a low-pressure compressor.**
- ① **If it is impossible to clean them, the filters must be replaced.**

To reposition:

- ▶ Perform in reverse order

Cleaning the heat exchanger

Cleaning the heat exchanger

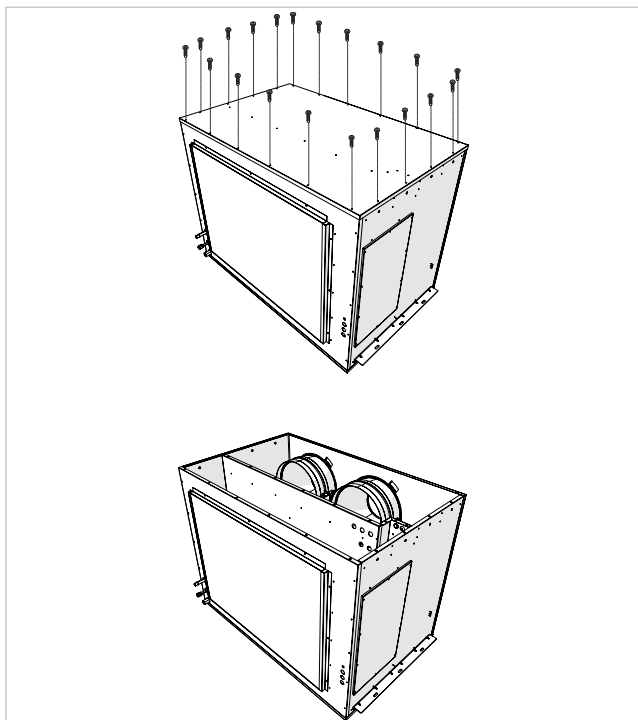

- ▶ Isolate the power supply to the unit
- ▶ Disconnect the condensate drain pipe
- ▶ Remove the filters (see chapter "Cleaning or filter replacement" p. 44)
- ▶ Remove the screws from the upper panel
- ▶ Remove the upper panel
- ▶ Proceed with cleaning carefully using a vacuum cleaner or a low-pressure compressor
- ▶ Reposition the upper panel using the screws previously removed
- ▶ Reposition the filters
- ⚠ Never touch the fins of the heat exchanger, handle only the closed sides.
- ① **To prevent dirt from entering the heat exchanger, clean in the opposite direction to the air flow.**

7. DECOMMISSIONING

7.1 Safety warnings

- ⚠ Before carrying out this procedure, it is essential that the technician has a complete understanding of the equipment and all its details.
- ⚠ It is recommended to safely recover all refrigerant
- ⚠ Before performing the activity, an oil and refrigerant sample must be taken in case an analysis is required before reusing the recovered refrigerant.
- ⚠ It is essential that the power supply is available before starting the activity.
- ⚠ Become familiar with the equipment and its operation.
- ⚠ Electrically isolate the system.
- ⚠ Before attempting the procedure, make sure that:
 - If necessary, mechanical handling equipment is available for handling refrigerant cylinders
 - all personal protective equipment is available and used properly
 - the recovery process should be supervised at all times by a competent person
 - the recovery equipment and cylinders comply with the appropriate standards
- ⚠ If possible, evacuate the refrigeration system.
- ⚠ If it is not possible to achieve a vacuum, create a manifold so that the refrigerant can be removed from various parts of the system.
- ⚠ Make sure the cylinder is weighed on the scale before the recovery takes place.
- ⚠ Start the recovery machine and operate it according to the manufacturer's instructions.
- ⚠ Do not overfill the cylinders. No more than 80% of the liquid charge volume.
- ⚠ Do not exceed the maximum working pressure of the cylinder, even temporarily.
- ⚠ When the cylinders have been filled correctly and the process is complete, ensure that the cylinders and equipment are removed from the site in a timely manner and that all isolation valves on the equipment have been closed.
- ⚠ The recovered refrigerant must not be charged into another refrigeration system unless it has been cleaned and checked.

8. FAULTS AND REMEDIES

8.1 Preliminary warnings

If one of the following faults is found:

- the appliance makes excessive noise
- there is dew formation on the front panel

Follow the instructions below:

- ▶ Immediately disconnect the power supply

- ▶ Close the water taps
- ▶ Contact an authorized Technical Support Service or professionally qualified personnel
- ⚠ The intervention must be carried out by a qualified installer or an Authorised Service Centre.
- ⊘ Personal intervention is prohibited.

8.2 Anomalies reported by the control panel

Anomalies are reported on the display of the control panel.

⚠ For the reading, refer to the Control Panel Manual.

Manual reset of alarms

If an anomaly repeats multiple times, the device goes into safety mode, and the alarm must be manually reset.

⚠ To restore, refer to the Control Panel Manual.

8.3 Functional aspects not to be interpreted as faults

- During the operation of the device, the following functional aspects may occur. These unit behaviors are to be considered regular and should not be interpreted as anomalies.
- The compressor will not restart until 3 minutes have elapsed since it was switched off.
- While the heat pump appliances are heating up, heat is delivered a few minutes after the compressor is switched on.
- Periodic defrosting cycles occur during heating operation.
- When switching from producing domestic hot water to cooling, and vice versa, the external heat pump remains off for one minute to prevent mixing between hot and cold water.

8.4 Alarms displayed on the control panel

The control panel of the external unit allows for the display of alarms that occur during the operation of the heat pump.

⚠ If the user interface shows the PdC alarm, refer to the Technical Support Center.

Alarms displayed	Cause	Remedy
P03	Abnormal compressor discharge temperature > or = to 103 °C.	Check the refrigeration cycle (possible excessive refrigerant charge). Verify the opening of the refrigerant valves. Check the compressor discharge temperature probe (TD) and replace if necessary.
P04	High-pressure switch intervention on the external unit.	In the summer cycle, check the free circulation of air around the outdoor unit. Verify the refrigerant charge. In the winter cycle, check the opening of the refrigerant valves.
P05	Detection of absence of one phase or incorrect phase connection in the three-phase version. Lack of neutral in single-phase versions.	Check the presence and sequence of the power supply phases R, S, and T, and in single-phase systems ensure the appliance is not powered by two phases.
P10	Missing or disconnected electrical bridge on connector CN034 of the PAW-ACXA73-38670 board.	Check the connection.
P11	Missing or disconnected electrical bridge on connector CN068 of the PAW-ACXA73-38670 board.	Check the connection.
P13	Alarm valve open	
P15	Detection of insufficient refrigerant charge.	Check the refrigeration circuit for potential leaks.
P14	O2 sensor detection	
P16	Excessive compressor absorption.	Check resistance values.
P22	External fan motor malfunctioning. Protection of the external fan inverter circuit activated.	Check for free movement of the fan. Replace the fan motor inverter board.
P31	Group control error	
P29	The compressor is not functioning correctly.	Remove and restore power to the appliance and check the correct restart of the compressor.
H01	Overcurrent detected by the compressor's Inverter board.	Check the wiring of the Inverter board and replace it if necessary. The radiant plate cooling issue of the Inverter board. Check the cleanliness of the heatsink. Check the electrical connections of the compressor.
H02	PAM issues	
H03	Primary CT current sensor failure (TO)	
H31	Malfunction of the HIC driver board	Contact the Technical Support Center to arrange for the replacement.
F01	The liquid sensor E1 on the indoor unit is disconnected, interrupted, or short-circuited.	Check the sensor and consider replacing it if needed.
F02	The condensation sensor E2 on the indoor unit is disconnected, interrupted, or short-circuited.	Check the sensor and consider replacing it if needed.
F04	The compressor discharge sensor TD is disconnected, interrupted, or short-circuited.	Check the sensor and consider replacing it if needed.
F06	The liquid sensor C1 on the outdoor unit's coil is disconnected, interrupted, or short-circuited.	Check the sensor and consider replacing it if needed.
F07	The condensation sensor C2 on the outdoor unit's coil is disconnected, interrupted, or short-circuited.	Check the sensor and consider replacing it if needed.
F08	The outdoor temperature sensor TO is disconnected, interrupted, or short-circuited.	Check the sensor and consider replacing it if needed.
F10	Problem with the indoor air temperature sensor (TA).	Check the sensor and, if necessary, consider its replacement.
F12	The compressor suction sensor TS is disconnected, interrupted, or short-circuited.	Check the sensor and consider replacing it if needed.
F29	EEPROM problem in the indoor unit.	Power cycle the unit and verify proper operation. Replace the PAW-ACXA73-38670 board's EEPROM.
F31	EEPROM problem in the outdoor unit.	Switch the appliance off and on again and check for proper operation. Replace and reprogram the electronic board of the outdoor unit.

Alarms displayed	Cause	Remedy
L02	Parameter incompatibility between the indoor and outdoor unit.	Perform the automatic address setting again. Contact the Service for reprogramming.
L04	Duplicate address of the outdoor unit	
L10	Lack of settings in the outdoor unit.	
L13	Incorrect parameter setting in the indoor unit.	
L08	Indoor unit address not set.	
L09	Indoor unit capacity not set.	
L18	Malfunction of 4 way valve. The probes E1 and E2 detect low temperatures during heating. The probes E1 and E2 detect high temperatures during cooling.	It could be a transitory situation. Switch the appliance off and on again and check for proper operation.
E01	Automatic address setting was not completed. The wirings between the indoor and outdoor units are cut or not properly connected.	Check the connection between the indoor and outdoor units.
E04	Error in receiving signals from the indoor unit.	
E06	Communication problems between the outdoor and indoor units.	
E03	Error in the indoor unit receiving the signal from the remote controller (central).	Check the connection between the indoor unit and the controller(s) (local and/or central).
E09	More than one remote control is set to main error	
E10	Faulty communication between main PCB and fan motor PCB	
E12	Automatic address setting start is prohibited while automatic address setting is in progress	
E14	Duplicate main unit in multi-control simultaneous operation	
E15	The power of the indoor unit is lower than that of the outdoor unit.	Check the sizes of the unit and have the indoor unit reconfigured.
E16	The power of the outdoor unit is lower than that of the indoor unit.	Check the sizes of the unit and have the indoor unit reconfigured.
E18	Faulty communication in group control wiring	
E20	Automatic addressing procedure interrupted.	Check the connection between the indoor and outdoor units.

 For further details, refer to the service manual

9. TECHNICAL INFORMATION

9.1 Technical data

Indoor unit

Models	u.m.	P-VTVF140xC5A-PE	P-VTVF250xC5A-PE
Heating performance (A 7/6; A 20) (1)			
Nominal total capacity	kW	14,13	26,69
Minimum total capacity	kW	4,17	6,31
Maximum total capacity	kW	15,83	29,89
COP	(2)	3,88	3,74
COP (maximum - minimum)	(2)	5,53÷3,49	5,83÷3,36
Cooling performance (A 35; A 27/19) (3)			
Nominal total capacity	kW	14,01	24,18
Minimum total capacity	kW	4,11	6,12
Maximum total capacity	kW	16,58	26,53
EER	(2)	3,46	3,80
EER (maximum - minimum)	(2)	5,15÷2,62	5,31÷2,95
Airflow performance			
Nominal air flow rate	m ³ /h	2.560	5.010
Available pressure	Pa	170	170
Supply fan			
Type		Radial	
Number	No.	1	2
Maximum absorbed power	W	330	660
Sound levels			
Sound power radiated in the Lw channel	dB (A)	60,0	64,0
Average sound pressure at 3 m Lp	dB(A)	42,0	46,0
Electrical characteristics			
Power supply	V / ph / Hz	230 / 1 / 50	
Nominal absorbed power	kW	0,33	0,66
Total absorbed current	A	1,70	3,40
Protection rating	IP	X2	
Product dimensions			
Width	mm	1.106	1.458
Depth	mm	929	988
Height	mm	808	1.041
Weight	kg	93,0	140,0
1. Outdoor air temperature: 7 °C b.s. and 6 °C b.u.; Indoor air temperature: 20 °C 2. EER and COP Classification according to EN14511 directive 3. Outdoor air temperature: 35 °C b.s.; Indoor air temperature: 27 °C b.s. and 19 °C b.u.			

Models	u.m.	P-VTVF140xC5A-PE	P-VTVF250xC5A-PE
Connections			
Air connections (Ø)	mm	355	355
Condensate drain connection	mm	30	30
1. Outdoor air temperature: 7 °C b.s. and 6 °C b.u.; Indoor air temperature: 20 °C 2. EER and COP Classification according to EN14511 directive 3. Outdoor air temperature: 35 °C b.s.; Indoor air temperature: 27 °C b.s. and 19 °C b.u.			

Outdoor unit

Models	u.m.	U-140PZH4E5	U-140PZH4E8	U-250PZH4E8
Heating airflow performance				
Maximum flow rate	m ³ /h	4.980	4.980	8.880
Cooling airflow performance				
Maximum flow rate	m ³ /h	5.340	5.340	6.960
Compressor				
Type		Rotary inverter		
Number	No.	1	1	1
Refrigerant type		R32		
Refrigerant quantity	kg	3,00	3,00	4,80
Heating sound levels				
Sound power transmitted to the Lw structure	dB (A)	76,0	76,0	82,0
Average sound pressure at 1 m Lp	dB(A)	56,0	56,0	63,0
Cooling sound levels				
Sound power transmitted to the Lw structure	dB (A)	76,0	76,0	76,0
Average sound pressure at 1 m Lp	dB(A)	56,0	56,0	57,0
Electrical characteristics				
Power supply	V / ph / Hz	230 / 1 / 50	400 / 3 / 50	400 / 3 / 50
Maximum total absorbed power	kW	7	7	12
Maximum total absorbed current	A	32,70	10,50	18,10
Protection rating	IP	X4		
Limits in heating				
Minimum outdoor air temperature	°C	-20,0	-20,0	-20,0
Maximum outdoor air temperature	°C	24,0	24,0	24,0
Limits in cooling				
Minimum outdoor air temperature	°C	-15,0	-15,0	-15,0
Maximum outdoor air temperature	°C	52,0	52,0	52,0
Product dimensions				
Width	mm	980	980	1.140
Depth	mm	370	370	460
Height	mm	996	996	996
Weight	kg	86,0	84,0	109,0

Models	u.m.	U-140PZH4E5	U-140PZH4E8	U-250PZH4E8
Connections				
Liquid connection	"SAE	3/8	3/8	1/2
Gas connection	"SAE	5/8	5/8	7/8

9.2 Fuse Characteristics

Fuse	Rating (A)	Voltage (V)	Type	Characteristic Curve
F1	10	500	CH10	gG

9.3 Dimensions

Size 140

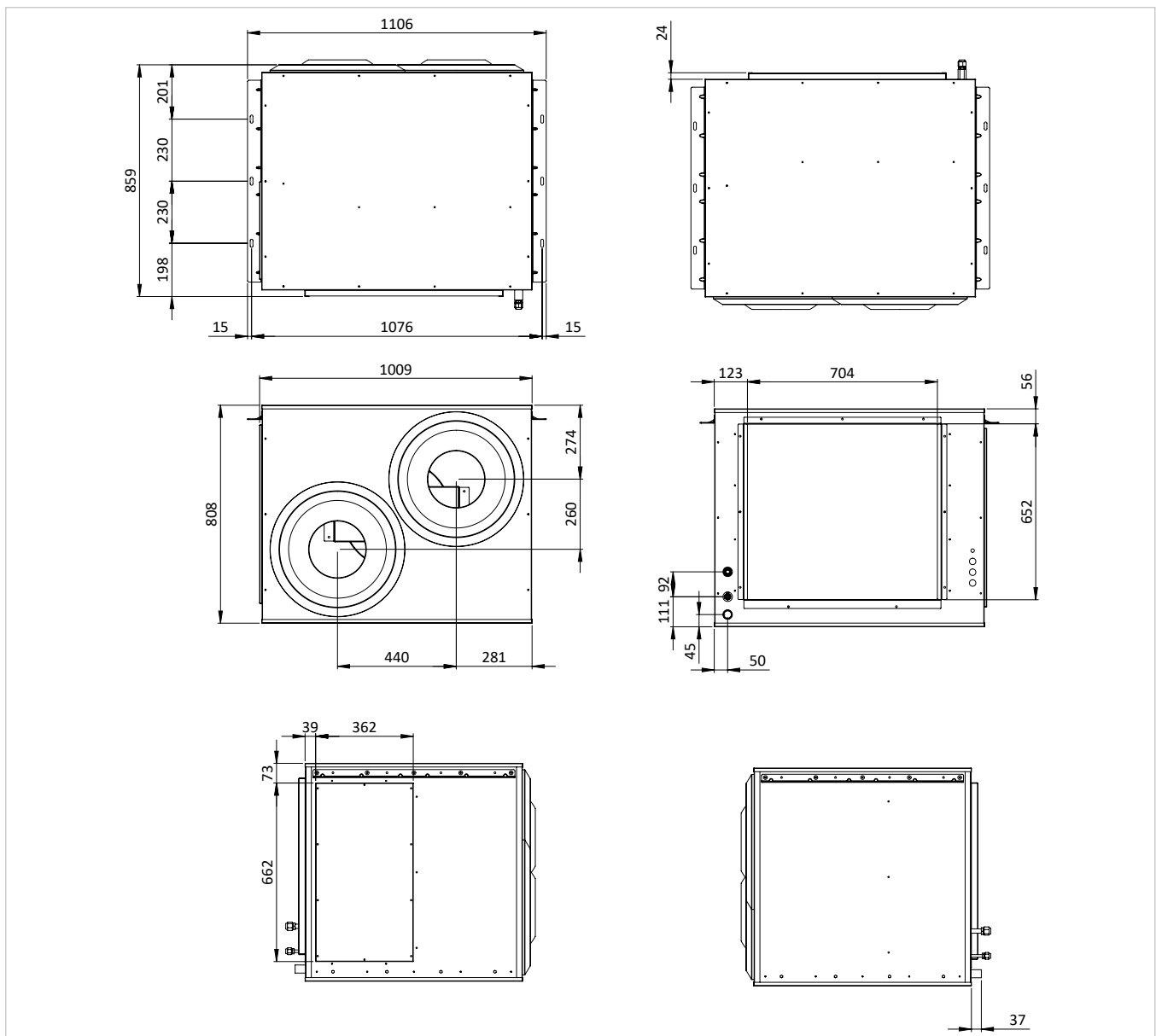

Size 250

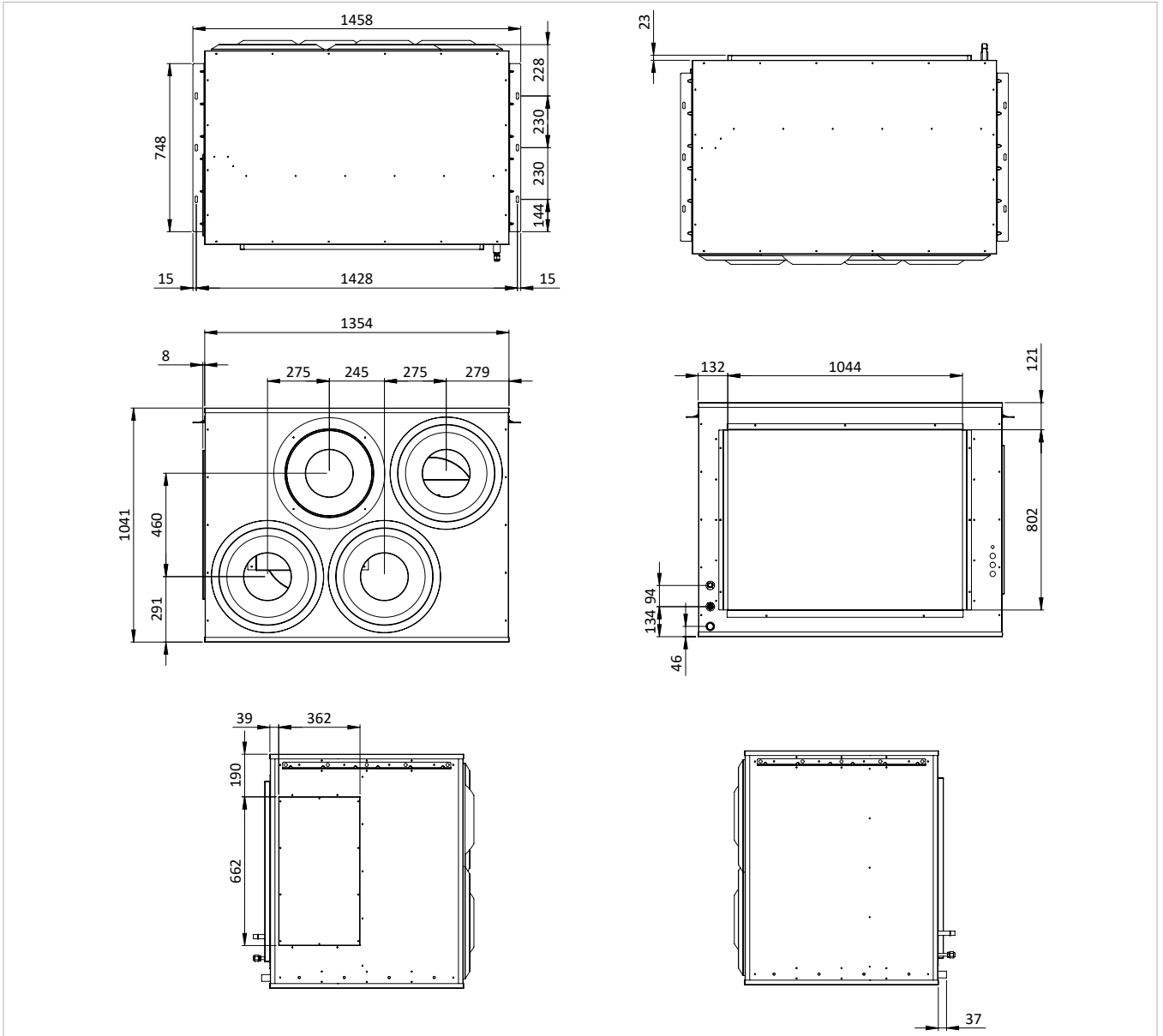

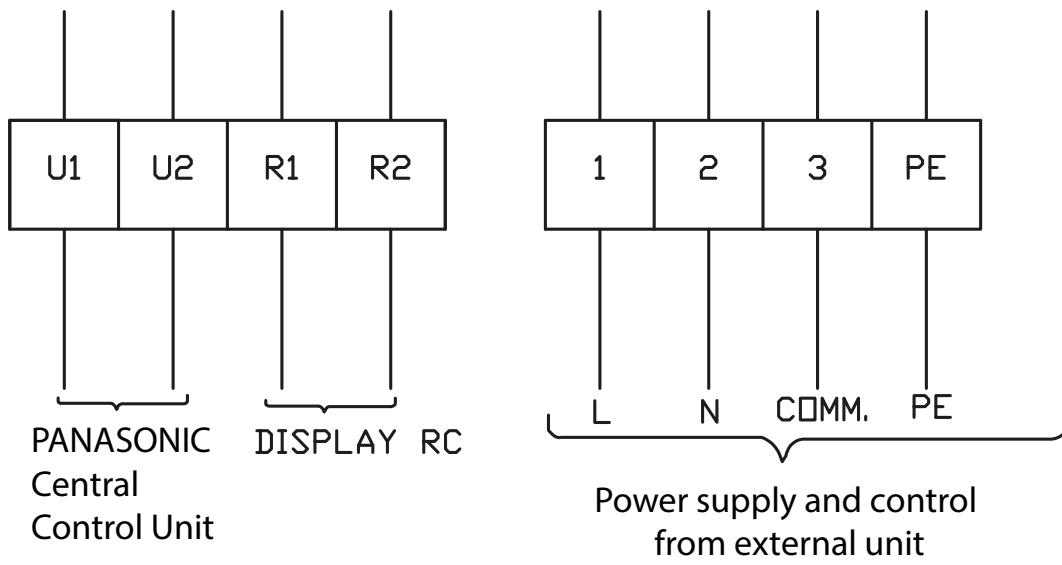
Terminal block

9.5 Ecodesign classification

U-140PZH4E5

PRODUCT FICHE according to European Regulation n° 2016/2281:

Information requirements for air-to-air air conditioners

Model(s):	Outdoor Unit	U-140PZH4E5					
	Indoor Unit	P-VTVF140MC5A-PE P-VTVF140NC5A-PE P-VTVF140PC5A-PE					
Outdoor side heat exchanger of air conditioner:	Air						
Indoor side heat exchanger of air conditioner:	Air						
If applicable: driver of the compressor :	electric motor						
Item	Symbol	Value	Unit	Item	Symbol	Value	Unit
Rated cooling capacity	$P_{rated,c}$	15,11	kW	Seasonal space cooling energy efficiency	$\eta_{s,c}$	227	%
Declared cooling capacity for part load at given outdoor temperatures T_j and indoor 27/19 °C (dry/wet bulb)				Declared energy efficiency ratio or gas utilisation efficiency/auxiliary energy factor for part load at given outdoor temperature T_j			
$T_j = +35^\circ\text{C}$	P_{dc}	14,0	kW	$T_j = +35^\circ\text{C}$	EER_d	3,5	%
$T_j = +30^\circ\text{C}$	P_{dc}	9,3	kW	$T_j = +30^\circ\text{C}$	EER_d	4,6	%
$T_j = +25^\circ\text{C}$	P_{dc}	6,9	kW	$T_j = +25^\circ\text{C}$	EER_d	6,5	%
$T_j = +20^\circ\text{C}$	P_{dc}	3,3	kW	$T_j = +20^\circ\text{C}$	EER_d	11,4	%
Degradation coefficient for air conditioners(*)	C_{dc}	0,25	Default 0,25 if not measured				
Power consumption in modes other than "active mode"							
Off mode	P_{OFF}	0,015	kW	Crankcase heater mode	P_{CK}	0,00	kW
Thermostat-off mode	P_{TO}	0,029	kW	Standby mode	P_{SB}	0,029	kW
Other items							
Capacity control	fixed/Staged/variable	variable		For air to air air conditioner: air flow rate, outdoor measured	-	5340	m ³ /h
Sound power level, indoors	L_{WA}	58	dB				
Sound power level, outdoors	L_{WA}	74	dB				
Emissions of nitrogen oxides	NO_x (**)	-	mg/kWh fuel input GCV				
GWP of the refrigerant		675	kg CO ₂ eq (100 years)				
Contact details	Panasonic Testing Centre, Panasonic Marketing Europe GmbH Winsbergring 15, 22525 Hamburg, Germany						
(*) If C_{dc} is not determined by measurement then the default degradation coefficient air conditioners							
(**) From 26 September 2018.							
Where information relates to multi-split air conditioners, the test result and performance data may be obtained on the basis of the performance of the outdoor unit, with a combination of indoor unit(s) recommended by the manufacturer or importer.							

PRODUCT FICHE according to European Regulation n° 2016/2281:							
Information requirements for heat pumps							
Model(s):	Outdoor Unit	U-140PZH4E5					
	Indoor Unit	P-VTVF140MC5A-PE P-VTVF140NC5A-PE P-VTVF140PC5A-PE					
Outdoor side heat exchanger of air conditioner:	Air						
Indoor side heat exchanger of air conditioner:	Air						
Indication if the heater is equipped with a supplementary heater:	No						
If applicable: driver of the compressor :	Electric motor						
Parameters shall be declared for the average heating season, parameters for the warmer and colder heating seasons are optional.							
Item	Symbol	Value	Unit	Item	Symbol	Value	Unit
Rated heating capacity	$P_{rated,h}$	14,13		Seasonal space heating energy efficiency	$\eta_{s,h}$	155	%
Declared heating capacity for part load at indoor temperature 20 °C and outdoor temperature T_j				Declared energy efficiency ratio or gas utilisation efficiency/auxiliary energy factor for part load at given outdoor temperature T_j			
$T_j = -7\text{ °C}$	P_{dh}	9,4	kW	$T_j = -7\text{ °C}$	COP_d	2,8	%
$T_j = +2\text{ °C}$	P_{dh}	6,3	kW	$T_j = +2\text{ °C}$	COP_d	3,7	%
$T_j = +7\text{ °C}$	P_{dh}	4,2	kW	$T_j = +7\text{ °C}$	COP_d	5,5	%
$T_j = +12\text{ °C}$	P_{dh}	4,3	kW	$T_j = +12\text{ °C}$	COP_d	6,2	%
T_{biv} = bivalent temperature	P_{dh}	11,0	kW	T_{biv} = bivalent temperature	COP_d	2,3	%
T_{OL} = operation limit	P_{dh}	7,7	kW	T_{OL} = operation limit	COP_d	1,8	%
For air-to-water heat pumps: $T_j = -15\text{ °C}$ (if $T_{OL} < -20\text{ °C}$)	P_{dh}	-	kW	For air-to-water heat pumps: $T_j = -15\text{ °C}$ (if $T_{OL} < -20\text{ °C}$)	COP_d	-	%
Bivalent temperature	T_{biv}	-10	°C	For water-to-air heat pumps: Operation limit temperature	T_{OL}	-20	°C
Degradation coefficient for air conditioners(**)	C_{dh}	0,25	-				
Power consumption in modes other than "active mode"				Supplementary heater			
Off mode	P_{OFF}	0,015	kW	Back-up heating capacity (*)	el_{bu}	0,0	kW
Thermostat-off mode	P_{TO}	0,029	kW	Type of energy input			
Crankcase heater mode	P_{CK}	0,000	kW	Standby mode	P_{ss}	0,029	kW
Other items							
Capacity Control	fixed/staged/variable	Variable		For air-to-air air conditioner: air flow rate, outdoor measured		4980	m³/h
Sound power level, indoors/outdoors measured	L_{WA}	58	dB	heat pumps: Rated brine or water flow		-	m³/h
Sound power level, outdoors measured	L_{WA}	74	dB				
Emissions of nitrogen oxides	-	-	mg/kWh fuel input GCV				
GWP of the refrigerant		675	kg CO ₂ eq (100 years)				
Contact details	Panasonic Testing Centre, Panasonic Marketing Europe GmbH Winsbergring 15, 22525 Hamburg, Germany						
(*) If C_{dh} is not determined by measurement then the default degradation coefficient of heat pumps shall be 0,25.							
(**) Where information relates to multi-split heat pumps, the test result and performance data may be obtained on the basis of the performance of the outdoor unit, with a combination of indoor unit(s) recommended by the manufacturer or importer.							
(***) From 26 September 2018.							

U-140PZH4E8

PRODUCT FICHE according to European Regulation n° 2016/2281:

Information requirements for air-to-air air conditioners

Model(s):	Outdoor Unit	U-140PZH4E8					
	Indoor Unit	P-VTVF140MC5A-PE P-VTVF140NC5A-PE P-VTVF140PC5A-PE					
Outdoor side heat exchanger of air conditioner:	Air						
Indoor side heat exchanger of air conditioner:	Air						
If applicable: driver of the compressor :	electric motor						
Item	Symbol	Value	Unit	Item	Symbol	Value	Unit
Rated cooling capacity	$P_{rated,c}$	15,11	kW	Seasonal space cooling energy efficiency	$\eta_{s,c}$	227	%
Declared cooling capacity for part load at given outdoor temperatures T_j and indoor 27/19 °C (dry/wet bulb)				Declared energy efficiency ratio or gas utilisation efficiency/auxiliary energy factor for part load at given outdoor temperature T_j			
$T_j = +35^\circ\text{C}$	P_{dc}	14,0	kW	$T_j = +35^\circ\text{C}$	EER_d	3,5	%
$T_j = +30^\circ\text{C}$	P_{dc}	9,3	kW	$T_j = +30^\circ\text{C}$	EER_d	4,6	%
$T_j = +25^\circ\text{C}$	P_{dc}	6,9	kW	$T_j = +25^\circ\text{C}$	EER_d	6,5	%
$T_j = +20^\circ\text{C}$	P_{dc}	3,3	kW	$T_j = +20^\circ\text{C}$	EER_d	11,4	%
Degradation coefficient for air conditioners(*)							
	C_{dc}	0,25	Default 0,25 if not measured				
Power consumption in modes other than "active mode"							
Off mode	P_{OFF}	0,015	kW	Crankcase heater mode	P_{ck}	0,00	kW
Thermostat-off mode	P_{TO}	0,029	kW	Standby mode	P_{sb}	0,029	kW
Other items							
Capacity control	fixed/Staged/variable	variable		For air to air air conditioner: air flow rate , outdoor measured	-	5340	m ³ /h
Sound power level, indoors	L_{WA}	58	dB				
Sound power level, outdoors	L_{WA}	76	dB				
Emissions of nitrogen oxides	NO_x (**)	-	mg/kWh fuel input GCV				
GWP of the refrigerant		675	kg CO ₂ eq (100 years)				
Contact details	Panasonic Testing Centre, Panasonic Marketing Europe GmbH Winsbergring 15, 22525 Hamburg, Germany						
(*) If C_{dc} is not determined by measurement then the default degradation coefficient air conditioners							
(**) From 26 September 2018.							
Where information relates to multi-split air conditioners, the test result and performance data may be obtained on the basis of the performance of the outdoor unit, with a combination of indoor unit(s) recommended by the manufacturer or importer.							

PRODUCT FICHE according to European Regulation n° 2016/2281:							
Information requirements for heat pumps							
Model(s):	Outdoor Unit	U-140PZH4E8					
	Indoor Unit	P-VTVF140MC5A-PE P-VTVF140NC5A-PE P-VTVF140PC5A-PE					
Outdoor side heat exchanger of air conditioner:	Air						
Indoor side heat exchanger of air conditioner:	Air						
Indication if the heater is equipped with a supplementary heater:	No						
If applicable: driver of the compressor :	Electric motor						
Parameters shall be declared for the average heating season, parameters for the warmer and colder heating seasons are optional.							
Item	Symbol	Value	Unit	Item	Symbol	Value	Unit
Rated heating capacity	$P_{rated,h}$	14,13		Seasonal space heating energy efficiency	$\eta_{s,h}$	155	%
Declared heating capacity for part load at indoor temperature 20 °C and outdoor temperature T_j				Declared energy efficiency ratio or gas utilisation efficiency/auxiliary energy factor for part load at given outdoor temperature T_j			
$T_j = -7\text{ °C}$	P_{dh}	9,4	kW	$T_j = -7\text{ °C}$	COP_d	2,8	%
$T_j = +2\text{ °C}$	P_{dh}	6,3	kW	$T_j = +2\text{ °C}$	COP_d	3,7	%
$T_j = +7\text{ °C}$	P_{dh}	4,2	kW	$T_j = +7\text{ °C}$	COP_d	5,5	%
$T_j = +12\text{ °C}$	P_{dh}	4,3	kW	$T_j = +12\text{ °C}$	COP_d	6,2	%
T_{biv} = bivalent temperature	P_{dh}	11,0	kW	T_{biv} = bivalent temperature	COP_d	2,3	%
T_{OL} = operation limit	P_{dh}	7,7	kW	T_{OL} = operation limit	COP_d	1,8	%
For air-to-water heat pumps: $T_j = -15\text{ °C}$ (if $T_{OL} < -20\text{ °C}$)	P_{dh}	-	kW	For air-to-water heat pumps: $T_j = -15\text{ °C}$ (if $T_{OL} < -20\text{ °C}$)	COP_d	-	%
Bivalent temperature	T_{biv}	-10	°C	For water-to-air heat pumps: Operation limit temperature	T_{OL}	-20	°C
Degradation coefficient for air conditioners(**)	C_{dh}	0,25	-				
Power consumption in modes other than "active mode"				Supplementary heater			
Off mode	P_{OFF}	0,015	kW	Back-up heating capacity (*)	el_{bu}	0,0	kW
Thermostat-off mode	P_{TO}	0,029	kW	Type of energy input			
Crankcase heater mode	P_{CK}	0,000	kW	Standby mode	P_{ss}	0,029	kW
Other items							
Capacity Control	fixed/staged/variable	Variable		For air-to-air air conditioner: air flow rate, outdoor measured		4980	m³/h
Sound power level, indoors/outdoors measured	L_{WA}	58	dB	heat pumps: Rated brine or water flow		-	m³/h
Sound power level, outdoors measured	L_{WA}	74	dB				
Emissions of nitrogen oxides	-	-	mg/kWh fuel input GCV				
GWP of the refrigerant		675	kg CO ₂ eq (100 years)				
Contact details	Panasonic Testing Centre, Panasonic Marketing Europe GmbH Winsbergring 15, 22525 Hamburg, Germany						
(*) If C_{dh} is not determined by measurement then the default degradation coefficient of heat pumps shall be 0,25.							
(**) Where information relates to multi-split heat pumps, the test result and performance data may be obtained on the basis of the performance of the outdoor unit, with a combination of indoor unit(s) recommended by the manufacturer or importer.							
(***) From 26 September 2018.							

U-250PZH4E8

PRODUCT FICHE according to European Regulation n° 2016/2281:

Information requirements for air-to-air air conditioners

Model(s):	Outdoor Unit	U-250PZH4E8					
	Indoor Unit	P-VTVF250MC5A-PE P-VTVF250NC5A-PE P-VTVF250PC5A-PE					
Outdoor side heat exchanger of air conditioner:	Air						
Indoor side heat exchanger of air conditioner:	Air						
If applicable: driver of the compressor :	electric motor						
Item	Symbol	Value	Unit	Item	Symbol	Value	Unit
Rated cooling capacity	$P_{rated,c}$	24,18	kW	Seasonal space cooling energy efficiency	$\eta_{s,c}$	250	%
Declared cooling capacity for part load at given outdoor temperatures T_j and indoor 27/19 °C (dry/wet bulb)				Declared energy efficiency ratio or gas utilisation efficiency/auxiliary energy factor for part load at given outdoor temperature T_j			
$T_j = +35^\circ\text{C}$	P_{dc}	24,2	kW	$T_j = +35^\circ\text{C}$	EER_d	3,8	%
$T_j = +30^\circ\text{C}$	P_{dc}	18,2	kW	$T_j = +30^\circ\text{C}$	EER_d	5,3	%
$T_j = +25^\circ\text{C}$	P_{dc}	10,8	kW	$T_j = +25^\circ\text{C}$	EER_d	8,2	%
$T_j = +20^\circ\text{C}$	P_{dc}	4,4	kW	$T_j = +20^\circ\text{C}$	EER_d	7,3	%
Degradation coefficient for air conditioners(*)	C_{dc}	0,25	Default 0,25 if not measured				
Power consumption in modes other than "active mode"							
Off mode	P_{OFF}	0,015	kW	Crankcase heater mode	P_{ck}	0,00	kW
Thermostat-off mode	P_{TO}	0,029	kW	Standby mode	P_{sb}	0,029	kW
Other items							
Capacity control	fixed/Staged/variable	variable		For air to air air conditioner: air flow rate, outdoor measured	-	6960	m ³ /h
Sound power level, indoors	L_{WA}	68	dB				
Sound power level, outdoors	L_{WA}	76	dB				
Emissions of nitrogen oxides	NO_x (**)	-	mg/kWh fuel input GCV				
GWP of the refrigerant		675	kg CO ₂ eq (100 years)				
Contact details	Panasonic Testing Centre, Panasonic Marketing Europe GmbH Winsbergring 15, 22525 Hamburg, Germany						
(*) If C_{dc} is not determined by measurement then the default degradation coefficient air conditioners							
(**) From 26 September 2018.							
Where information relates to multi-split air conditioners, the test result and performance data may be obtained on the basis of the performance of the outdoor unit, with a combination of indoor unit(s) recommended by the manufacturer or importer.							

PRODUCT FICHE according to European Regulation n° 2016/2281:							
Information requirements for heat pumps							
Model(s):	Outdoor Unit	U-250PZH4E8					
	Indoor Unit	P-VTVF250MC5A-PE P-VTVF250NC5A-PE P-VTVF250PC5A-PE					
Outdoor side heat exchanger of air conditioner:	Air						
Indoor side heat exchanger of air conditioner:	Air						
Indication if the heater is equipped with a supplementary heater:	No						
If applicable: driver of the compressor :	Electric motor						
Parameters shall be declared for the average heating season, parameters for the warmer and colder heating seasons are optional.							
Item	Symbol	Value	Unit	Item	Symbol	Value	Unit
Rated heating capacity	$P_{rated,h}$	26,69		Seasonal space heating energy efficiency	$\eta_{s,h}$	155	%
Declared heating capacity for part load at indoor temperature 20 °C and outdoor temperature T_j				Declared energy efficiency ratio or gas utilisation efficiency/auxiliary energy factor for part load at given outdoor temperature T_j			
$T_j = -7\text{ °C}$	P_{dh}	16,4	kW	$T_j = -7\text{ °C}$	COP_d	2,8	%
$T_j = +2\text{ °C}$	P_{dh}	9,9	kW	$T_j = +2\text{ °C}$	COP_d	3,7	%
$T_j = +7\text{ °C}$	P_{dh}	6,3	kW	$T_j = +7\text{ °C}$	COP_d	5,8	%
$T_j = +12\text{ °C}$	P_{dh}	7,4	kW	$T_j = +12\text{ °C}$	COP_d	6,0	%
T_{biv} = bivalent temperature	P_{dh}	18,5	kW	T_{biv} = bivalent temperature	COP_d	2,4	%
T_{OL} = operation limit	P_{dh}	15,3	kW	T_{OL} = operation limit	COP_d	1,9	%
For air-to-water heat pumps: $T_j = -15\text{ °C}$ (if $T_{OL} < -20\text{ °C}$)	P_{dh}	-	kW	For air-to-water heat pumps: $T_j = -15\text{ °C}$ (if $T_{OL} < -20\text{ °C}$)	COP_d	-	%
Bivalent temperature	T_{biv}	-10	°C	For water-to-air heat pumps: Operation limit temperature	T_{OL}	-20	°C
Degradation coefficient for air conditioners(**)	C_{dh}	0,25	-				
Power consumption in modes other than "active mode"				Supplementary heater			
Off mode	P_{OFF}	0,015	kW	Back-up heating capacity (*)	el_{bu}	0,0	kW
Thermostat-off mode	P_{TO}	0,029	kW	Type of energy input			
Crankcase heater mode	P_{CK}	0,000	kW	Standby mode	P_{ss}	0,029	kW
Other items							
Capacity Control	fixed/staged/variable	Variable		For air-to-air air conditioner: air flow rate, outdoor measured		8880	m ³ /h
Sound power level, indoors/outdoors measured	L_{WA}	68	dB	heat pumps: Rated brine or water flow		-	m ³ /h
Sound power level, outdoors measured	L_{WA}	82	dB				
Emissions of nitrogen oxides	-	-	mg/kWh fuel input GCV				
GWP of the refrigerant		675	kg CO ₂ eq (100 years)				
Contact details	Panasonic Testing Centre, Panasonic Marketing Europe GmbH Winsbergring 15, 22525 Hamburg, Germany						
(*) If C_{dh} is not determined by measurement then the default degradation coefficient of heat pumps shall be 0,25.							
(**) Where information relates to multi-split heat pumps, the test result and performance data may be obtained on the basis of the performance of the outdoor unit, with a combination of indoor unit(s) recommended by the manufacturer or importer.							
(***) From 26 September 2018.							

Panasonic®

Panasonic HVAC & CC Co., Ltd.
Head office: Panasonic Tokyo Shiodome
Building, 1-5-1 Higashi-Shimbashi, Minato-ku,
Tokyo
Registered office: 1006, Oaza Kadoma,
Kadoma-shi, Osaka