

Installation and Control
Installation Manual
(original instructions)

EN

Panasonic[®]

N421141A - Rev.04 - 05/2025

Aquarea Loop

P-CWSL series**

First of all, we would like to thank you for having chosen a device of our production.

We are sure you will be happy with it because it represents the state of the art in the technology of home air conditioning.

By following the suggestions contained in this manual, the product you have purchased will provide trouble free operation, giving you optimum room temperatures with minimum energy costs.

Panasonic Corporation

Conformity

This unit complies with the European directives:

- EN 60335-2-40 Household and similar electrical appliances - Safety Part 2-40: Particular requirements for electrical heat pumps, air-conditioners and dehumidifiers
- Low Voltage Directive 2014/35/UE
- EMC Directive 2014/30/EU
- RED Directive 2014/53/UE on the harmonisation of the laws of the Member States relating to the making available on the market of radio equipment
- RoHS Directive 2011/65/EU
- Directive 2017/1369/EU on energy labelling
- 2009/125/EU Directive and implementing regulation 206/2012/EU and Italian implementing regulation Legislative Decree no. 15 of 16/02/2011
- F-Gas Regulation 2014/517/EU on fluorinated greenhouse gases

And subsequent amendments.

⚠ For declarations of conformity, certificates and other certification details please consult the website.

Markings



TABLE OF CONTENTS

1. Coding	5		
1.1 Product related coding	5	6.13 Filling the plant.	35
2. General information	6	6.14 Electric connections	37
2.1 About the manual	6	6.15 Assembly of aesthetic panels and grilles	40
2.2 General warnings	7		
2.3 Basic rules of security	8	7. Touchpad - Interface	41
2.4 Disposal	8	7.1 Interface	41
3. Product presentation.	10	8. Touchpad - Menu structure	42
3.1 Identification	10	8.1 Touchpad	42
3.2 Destination of use	10	9. Touchpad - Settings	46
3.3 Description of the appliance	10	9.1 Basic menu	46
3.4 Components.	11	9.2 Advanced Menu	47
3.5 Compatible accessories	12	9.3 View menu.	48
4. Critical issues in the replacement of radiators in building upgrades.	13	9.4 Start menu.	48
4.1 Problems related to dirt.	13	9.5 Visualisation of alarms on display.	49
4.2 Solutions.	13	10. Wall-mounted control Cod. PCZ-EEB749	50
4.3 Problems related to connection reversal	13	10.1 Interface	50
4.4 Solutions.	13	10.2 Installation	51
5. Pre-installation	15	10.3 Single connection diagram	53
5.1 Existing system survey	15	10.4 Multiple connection diagram	54
5.2 Existing terminal inlet/outlet survey	20	10.5 Connections.	55
5.3 Removal of previously installed terminals	21	10.6 Basic menu	56
5.4 Flow indicator.	21	10.7 Advanced Menu	57
5.5 Flushing and washing the system.	22	10.8 Alarm display on wall control panel	58
6. Installation	24	11. Wall-mounted control PCZ-EFB749	59
6.1 Preliminary warnings	24	11.1 Interface	59
6.2 Reception	24	11.2 Installation	60
6.3 Dimensions and weights with packaging	25	11.3 Single connection diagram	62
6.4 Handling with packaging	25	11.4 Multiple connection diagram	63
6.5 Storage.	26	11.5 Connections.	64
6.6 Unpacking.	26	11.6 Functions	65
6.7 Handling without packaging.	27	12. Putting it into service	68
6.8 Installation site.	27	12.1 Preliminary warnings	68
6.9 Installation minimum distances.	28	12.2 First start-up	68
6.10 Positioning	28	12.3 Plant delivery	72
6.11 Condensation drain preparation	31	12.4 Long period shut-down	72
6.12 Hydraulic connections.	32	12.5 Draining the plant	72

13. Maintenance	73
13.1 Preliminary warnings	73
13.2 Once-a-year operations	73
14. Troubleshooting	76
14.1 Troubleshooting table.	76
14.2 Visualisation of alarms on display.	77
15. Configuration accessories	78
15.1 Basic hydronic kit	78
15.2 2/3-way on/off valve kit	78
15.3 2/3-way modulating valve kit	79
15.4 Injection pump kit	79
16. Technical information	81
16.1 Technical data.	81
16.2 Operating limits	82
16.3 Dimensions	83
16.4 Installation template	83
16.5 Information requirements for water/ brine-to-air air conditioners	85
16.6 Information requirements for heat pumps	88

1. CODING

1.1 Product related coding

This instruction manual refers to the following product codes.





⚠ Check the correspondence with the technical rating plate on the product. See chapter "Identification" *p. 10*.

Code	Size	Connection side	Control Panel	Valves
P-CWSL10SC5-HBE	10	Vertical	On-board panel	2/3-way ON/OFF valve
P-CWSL20SC5-HBE	20	Vertical	On-board panel	2/3-way modulating valve
P-CWSL30SC5-HBE	30	Vertical	On-board panel	Without valve
P-CWSL10SC5-WBE	10	Vertical	On-board panel (Wi-Fi)	2/3-way on/off valve + injection kit
P-CWSL20SC5-WBE	20	Vertical	On-board panel (Wi-Fi)	2/3-way modulating valve + injection kit
P-CWSL30SC5-WBE	30	Vertical	On-board panel (Wi-Fi)	Without valve + injection kit
P-CWSL10SC5-HCE	10	Vertical	On-board panel	2/3-way ON/OFF valve
P-CWSL20SC5-HCE	20	Vertical	On-board panel	2/3-way modulating valve
P-CWSL30SC5-HCE	30	Vertical	On-board panel	Without valve
P-CWSL10SC5-WCE	10	Vertical	On-board panel (Wi-Fi)	2/3-way on/off valve + injection kit
P-CWSL20SC5-WCE	20	Vertical	On-board panel (Wi-Fi)	2/3-way modulating valve + injection kit
P-CWSL30SC5-WCE	30	Vertical	On-board panel (Wi-Fi)	Without valve + injection kit
P-CWSL10SC5-HEE	10	Vertical	On-board panel	2/3-way ON/OFF valve
P-CWSL20SC5-HEE	20	Vertical	On-board panel	2/3-way modulating valve
P-CWSL30SC5-HEE	30	Vertical	On-board panel	Without valve
P-CWSL10SC5-WEE	10	Vertical	On-board panel (Wi-Fi)	2/3-way on/off valve + injection kit
P-CWSL20SC5-WEE	20	Vertical	On-board panel (Wi-Fi)	2/3-way modulating valve + injection kit
P-CWSL30SC5-WEE	30	Vertical	On-board panel (Wi-Fi)	Without valve + injection kit
P-CWSL10SC5-HFE	10	Vertical	On-board panel	2/3-way ON/OFF valve
P-CWSL20SC5-HFE	20	Vertical	On-board panel	2/3-way modulating valve
P-CWSL30SC5-HFE	30	Vertical	On-board panel	Without valve
P-CWSL10SC5-WFE	10	Vertical	On-board panel (Wi-Fi)	2/3-way on/off valve + injection kit
P-CWSL20SC5-WFE	20	Vertical	On-board panel (Wi-Fi)	2/3-way modulating valve + injection kit
P-CWSL30SC5-WFE	30	Vertical	On-board panel (Wi-Fi)	Without valve + injection kit

2. GENERAL INFORMATION

2.1 About the manual





This manual was written to provide all the explanations for the correct management of the device.

-  This instruction manual forms an integral part of the device and therefore must be carefully preserved and must ALWAYS travel with it, even if you transfer the device to another owner or relocate it to other premises. If the manual gets damaged or lost, download a copy from the website.
-  Read this manual carefully before proceeding with any operation and follow the instructions in the individual chapters.
-  The Manufacturer accepts no liability for damages to persons or property caused by failure to follow the instructions in this manual.
-  This document is restricted in use to the terms of the law and may not be copied or transferred to third parties without the express authorisation of the Manufacturer.

2.1.1 Editorial pictograms

The pictograms in the next chapter provide the necessary information for correct and safe use of the machine in a rapid and unmistakable way.

Related to security

-  **High risk warning (bold text)**
 - The operation described above presents a risk of serious physical injury, fatality, major damage to the device and/or to the environment if not carried out in compliance with safety regulations.
-  Low risk warning (plain text)
 - The operation described above presents a risk of minor physical injury or minor damage to the device and/or to the environment if not carried out in compliance with safety regulations.
-  Prohibition (plain text)
 - Refers to prohibited actions.
-  **Important information (bold text)**
 - This indicates important information that must be taken into account during the operations.



In the texts

- ▶ procedures
- lists

In the control panels

- ▶ actions required
Expected responses following an action.

In the figures

- 1 The numbers indicate the individual components.
- A The capital letters indicate component assemblies.
-  The white numbers in black marks indicate a series of actions to be carried out in sequence.
-  The black letter in white identifies an image when there are several images in the same figure.

2.1.2 Pictograms on the product

Symbols are used in some parts of the device:

Related to security



Read instruction manual

Read the instructions carefully before performing any work on the device.



Instruction manual

Read the information available in the technical documentation of the device.



Caution: electrical danger

- The concerned personnel is informed to the presence of electricity and the risk of suffering an electric shock.

Related to refrigerant R290



Caution: low flammability material

- R290 refrigerant gas is flammable and odourless. Avoid proximity to ignition sources in continuous operation (open flames, gas appliances, electric stoves, burning cigarettes, etc.).



Instructions for the Authorised Service Centre

- The Authorised Service Centre must read the instructions carefully before performing any work on the appliance.

2.1.3 Recipients

User

Non-expert person capable of operating the product in safe conditions for people, for the product itself and the environment, interpreting an elementary diagnostic of faults and abnormal operating conditions, carrying out simple adjustment, checking and maintenance operations.

Installer

Expert person qualified to position and connect (hydraulically, electrically, etc.) the unit to the plant; this person is responsible for handling and correct installation according

to the instructions provided in this manual and the national standards currently in force.

To work on the refrigeration circuit, the installer must comply with the provisions of Regulation 303/2008/EC which defines, in accordance with Directive 842/2006/EC, the requirements for companies and personnel with regard to fixed refrigeration, air conditioning and heat pump equipment containing certain fluorinated greenhouse gases (F-gas licence).

Authorised Service Centre

Expert and qualified person authorised directly by the manufacturer to carry out all routine and supplementary maintenance operations, as well as every adjustment, check, repair and replacement of parts necessary during the life of the unit itself.

Service personnel must comply with the provisions of Regulation 303/2008/EC which defines, in accordance with Directive 842/2006/EC, the requirements for companies and personnel with regard to fixed refrigeration, air conditioning and heat pump equipment containing certain fluorinated greenhouse gases (F-gas licence).

2.1.4 Manual organisation

The manual is divided into sections each dedicated to one or more target groups.

General information

It addresses all recipients.

It contains general information and important warnings that should be known before installing and using the device.

Product presentation

It addresses all recipients.

It contains the information to identify the product, its components, compatible accessories and destination of use.

Critical issues and pre-installation

It addresses all recipients.

This contains information, warnings, precautions specific to Aquarea Loop installations.

Installation

It is addressed exclusively to the installer.

It contains specific warnings and all the information necessary for positioning, mounting and connecting the appliance.

Control panels

It is addressed only and exclusively to the Installer and the Authorised Service Centre.

These are sections dedicated to the different types of controls and electronic boards combined with the range with specific information for that combination.

Commissioning, maintenance and troubleshooting

They are addressed exclusively to the Authorised Service Centre.

It contains specific warnings useful information for the most common commissioning and routine maintenance.

Configuration accessories

It is addressed to the installer and the Authorised Service Centre.

It contains specific warnings and all detailed information on configuration accessories.

Technical information

It addresses all recipients.

It contains detailed technical information about the appliance.

2.2 General warnings

- ⚠ Specific warnings are given in each chapter of the document and must be read before starting operations.
- ⚠ All personnel involved must be aware of the operations and dangers that may arise when beginning all unit installation operations.
- ⚠ Installation performed outside the warnings provided in this manual and use of the appliance outside the prescribed temperature limits will invalidate the warranty.
- ⚠ The installation and maintenance of climate control equipment could be dangerous because there is pressurised refrigerant gas and live electrical components inside the appliances. The installation and subsequent maintenance phases must be carried out exclusively by authorised and qualified personnel.
- ⚠ Any contractual or extra-contractual liability for damage caused to persons, animals or property, due to installation adjustment and maintenance errors, or improper use, is excluded. All uses not expressly indicated in this manual are not permitted.
- ⚠ Only suitably qualified installers are authorised to install the device. After having completed installation, the installer will issue a declaration of conformity to the plant manager, as required by the applicable standards and the guidelines provided by contractor's instruction manual supplied with the device.
- ⚠ First start-up and repair or maintenance operations must be carried out by the Technical Assistance Centre or by qualified personnel following the provisions of this manual.
- ⚠ A list of the authorized Technical Service Centers can be found on the website, in the service section.
- ⚠ Do not modify or tamper with the appliance as this can lead to dangerous situations.
- ⚠ Use suitable personal protective clothing and equipment during installation and/or maintenance operations. The Manufacturer is not liable for the non-observance of the current safety and accident prevention regulations.
- ⚠ In the event of liquid or oil leaks, set the main switch of the plant to "OFF" and isolate water taps where applicable. Call the Authorised Service Centre or professionally qualified personnel as soon as possible and do not work on the appliance yourself.
- ⚠ In case of replacement of parts, use only original parts.

- ⚠ The Manufacturer reserves the right to make changes to its models at any time to improve its product, without prejudice to the essential characteristics described in this manual. The manufacturer is not obliged to add such modifications to machines previously manufactured, already delivered or under construction.
- ⚠ The unit can be used by children over the age of 8, and by people with reduced physical, sensory or mental capabilities, or with no experience or necessary knowledge, as long as they are monitored or after they have received instructions on the safe use of the unit and have understood the dangers involved. Children must not play with the appliance. The cleaning and maintenance that must be performed by the user should not be carried out by children without supervision.

2.2.1 Specific warnings for R290

i This document contains only some of the warnings related to the refrigerant R290. For more comprehensive information, carefully read the safety data sheet available from the dealer.

- ⚠ Each chapter contains specific warnings for the operations it describes. These warnings must be read before starting activities.
- ⚠ All precautions concerning the treatment of the refrigerant must be observed following the regulations in force.
- ⚠ The unit uses environmentally friendly R290 refrigerant gas, with a Global Warming Potential (GWP) = 3. Do not release R290 gas into the atmosphere.
- ⚠ R290 refrigerant gas is flammable and odourless.
- ⚠ Do not place flammable objects (spray cans) within 1 metre of the air outlet.
- ⚠ Avoid proximity to sources of ignition in continuous operation (open flames, gas appliances, electric stoves, lighted cigarettes, etc.).
- ⚠ If refrigerant gas escapes, ventilate the room abundantly and leave. Call the Authorised Service Centre or professionally qualified personnel as soon as possible and do not intervene on the appliance yourself.

2.3 Basic rules of security

Please keep in mind that the use of products powered by electricity and water call for operators to comply with certain essential safety rules:

- ⊖ It is forbidden to touch the device with wet or damp body parts.
- ⊖ It is forbidden to carry out any operation before disconnecting the appliance from the power supply by setting the plant main switch to "OFF".
- ⊖ It is forbidden to modify the safety or adjustment devices, or adjust without authorisation and indications of the Manufacturer.
- ⊖ It is forbidden to pull, unplug or twist the device's electric cables, even if it is disconnected from the mains.
- ⊖ It is forbidden to introduce objects and substances through the air inlet and outlet grilles.

- ⊖ It is forbidden to open the access doors of the device's internal parts without first having set main switch of the system to "OFF".
- ⊖ It is forbidden to incorrectly dispose of the packaging, or leave in the reach of children, which may become a source of danger.

2.3.1 Specific safety rules for R290

- i This document contains only some of the safety rules related to refrigerant R290. For more comprehensive information, carefully read the safety data sheet available from the dealer.**
- ⊖ Smoking in the vicinity of the appliance is prohibited.
- ⊖ Using a mobile phone near the appliance is prohibited.
- ⊖ Using leak detectors with halogen lamps is prohibited.

2.4 Disposal



The symbol on the product or packaging indicates that the product must not be treated as normal household waste, but must be taken to the appropriate collection point for recycling of used electrical and electronic equipment and batteries.

Proper disposal of this product avoids harm to humans and the environment and promotes the reuse of valuable raw materials.

For more detailed information about the recycling of this product, contact your local authority, your household waste disposal service or the shop where you purchased the product.

Illegal disposal of the product by the user involves the application of the administrative sanctions provided for by the regulations in force.

This provision is valid in the EU Member States.

- ⚠ Avoid disassembling the unit yourself.
- ⚠ This unit contains fluorinated greenhouse gases covered by the Kyoto Protocol. Maintenance and disposal operations must be carried out by qualified personnel only.
- ⚠ **Contact an Authorised Service Centre to disassemble the appliance.**

3. PRODUCT PRESENTATION

3.1 Identification

The appliance can be identified by the rating plate:

Technical rating plate

⚠ According to EU Regulation No. 517/2014 concerning certain fluorinated greenhouse gases, it is mandatory to indicate the total amount of refrigerant present in the installed system. This information can be found on the rating plate of the unit.

⚠ Tampering with, removal of, or lack of identification plates will not allow for the safe identification of the product by its serial number and therefore invalidates the warranty.

For removing the cover panels and grilles, refer to chapter "Device preparation" *p. 28*.

1. Technical rating plate

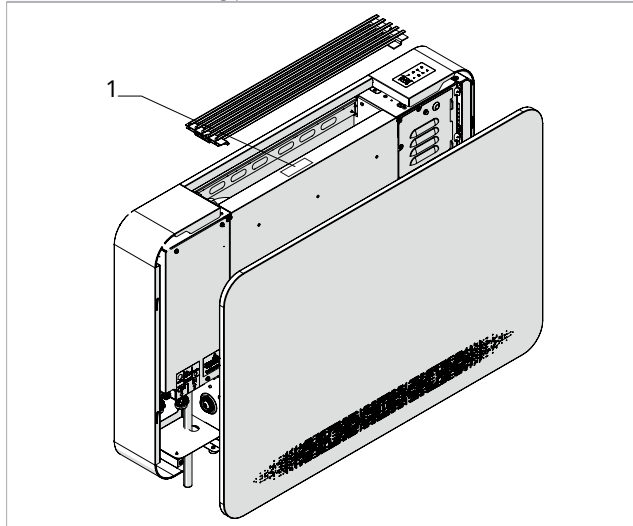

3.2 Destination of use

These appliances have been designed for conditioning and/or heating rooms and they must be destined solely for

this purpose, in accordance with their performance characteristics.

⊖ It is forbidden to use the device other than as indicated.

3.3 Description of the appliance

Aquarea Loop is a range of compact and efficient water/air heat pump terminals designed for indoor installation on walls in a vertical position.

Inverter technology allows optimised power for maximum comfort. Operation is via a touch panel located on the unit.

ⓘ The appliance is delivered from the factory with the Touchpad control panel fitted.

The appliance uses the refrigerant R290.

All models are heat pump models and are made in different sizes and performance:

- 10
- 20
- 30

1. Touchpad control panel

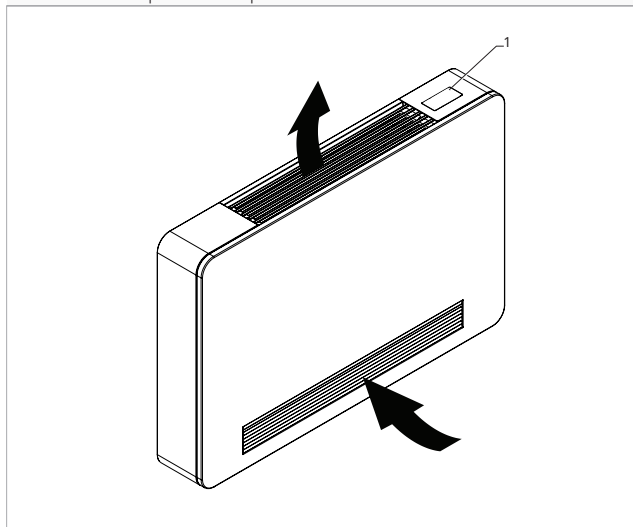

3.4 Components

3.4.1 External components

- | | |
|----|------------------------|
| 1. | Touchpad control panel |
| 2. | Upper grille |
| 3. | Front panel |
| 4. | Aesthetic side panel |

- | | |
|----|-----------------------------|
| 5. | Wall fixing bracket |
| 6. | Electrical connection entry |
| 7. | Hydraulic connection entry |
| 8. | Condensate drain |

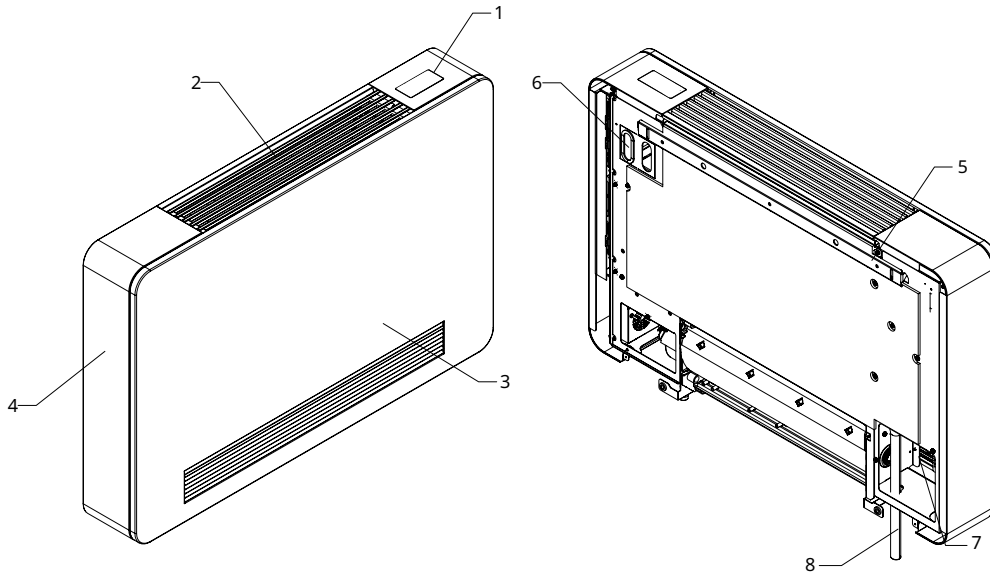

3.4.2 Internal components

- | | |
|----|------------------------------|
| 1. | Plate heat exchanger (water) |
| 2. | Hydraulic connections |
| 3. | Condensate drain |
| 4. | Fan |

- | | |
|----|----------------------|
| 5. | Filter |
| 6. | Heat exchanger (air) |
| 7. | Compressor |
| 8. | Electrical panel |

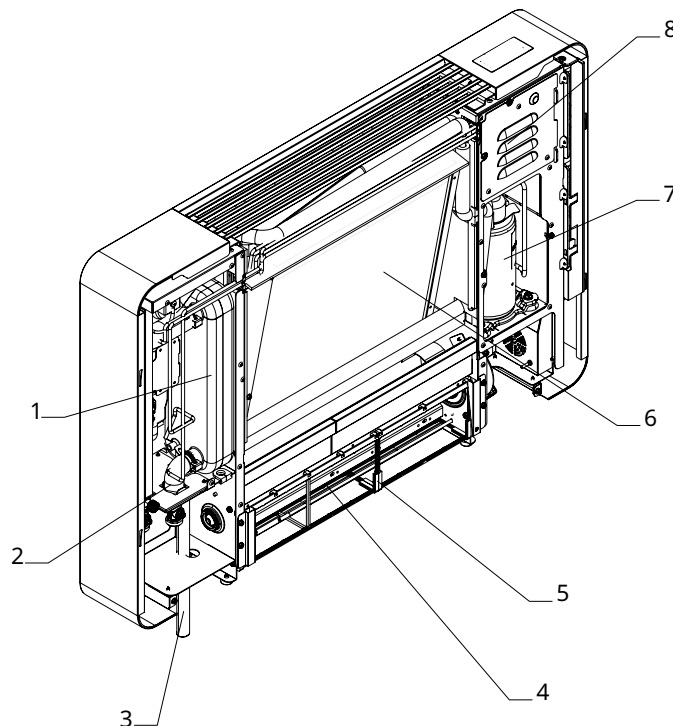

3.5 Compatible accessories

	Accessory description	Combinable products	Code
Wall-mounted control panels			
Control panels			
	LED electronic control panel with touch interface, wall mounted complete with thermostat and room temperature and relative humidity probe. Cable connection. White colour	All	PCZ-EEB749
	LED electronic control panel with touch interface, wall-mounted complete with thermostat and room temperature and relative humidity probe with integrated Wi-Fi module. Cable connection. White colour	All	PCZ-EFB749

4. CRITICAL ISSUES IN THE REPLACEMENT OF RADIATORS IN BUILDING UPGRADES

Replacing radiators in an existing system is a delicate operation that can lead to energy efficiency problems and

damage to heat pump components if it is not performed correctly.

4.1 Problems related to dirt

Dirt accumulated over time, corrosion of pipes, generate debris that if not removed properly can cause:

Clogging of the plate heat exchanger: plate heat exchangers are particularly sensitive to the accumulation of debris and dirt. Clogging can drastically reduce heat pump efficiency.

Compressor overload: a reduction of heat exchange in the heat exchanger can lead to an increase or excessive reduction in refrigerant pressure and temperature, overloading the compressor and increasing the risk of failure.

Ice formation: if the heat exchanger fails to exchange heat effectively, the refrigerant may not evaporate completely, leading to ice formation on the heat exchanger plates with consequent rupture and damage to the compressor.

Reduced water flow: dirt in the pipes can reduce the water flow to the plate heat exchanger, impairing the efficiency of the heat pump.

Balancing problems: dirt in the system can affect water flow distribution, making system balancing and temperature regulation difficult.

Pressure problems: debris and dirt can cause pressure variations in the system, which may require further maintenance.

Noise: accumulations of dirt can cause noises, such as gurgling or whistling, and are an indication non-optimal operation.

Control circuit faults: dirt can also interfere with sensors and other electronic components in the system, causing incorrect readings and temperature adjustment problems.

4.2 Solutions

The entire hydraulic system must be thoroughly cleaned before installing the new heat pump to minimise these risks. This will ensure efficient operation and also a longer life of the new equipment.

See chapter "Flushing and washing the system" p. 22.

⚠ The system must have been flushed prior to the installation of Aquarea Loop.

⊖ It is forbidden to install Aquarea Loop before flushing the system.

4.3 Problems related to connection reversal

The inlet and outlet in the hydraulic connections could be inverted when replacing terminals on existing installations. In heat pumps, flow reversal can cause:

Efficiency reduction: the plate heat exchanger of the heat pump is designed for countercurrent flow to maximise efficiency. Reversing the connections can significantly reduce heat exchange effectiveness.

Compressor overload: a reversed hydraulic flow can cause a malfunction in the cooling or heating cycle, putting the compressor under stress and increasing the risk of

failure. An incorrectly measured water flow from the Vortex could cause the compressor to work outside the permitted working range, increasing the risk of overload and failure.

Incorrect flow meter reading: if the flow meter does not provide accurate data, the system may have difficulty maintaining the desired temperature, compromising room comfort.

Unreliable diagnostics: an incorrectly measured water flow from the Vortex could lead to false or missing indications.

4.4 Solutions

The position of the appliances and the direction of the hydraulic connections must be accurately determined before removing existing radiators to avoid the problem of inverted hydraulic connections. Some modes that can be used:

Photographs and diagrams: take detailed photographs or draw diagrams of the existing system before starting work. This will provide a visual reference when installing the new system.

Clear labelling: clearly label all pipes and connections to know exactly where they will be connected in the new system.

Use of colours or distinctive signs: use coloured tape or other distinctive signs to mark the various water lines, such as hot and cold water lines.

Manuals and instructions: always consult the installation manuals provided by the radiator manufacturers. These usually contain detailed instructions on how to connect the hydraulic connections correctly.

Flow check: the heat distribution along the pipes can be viewed using a thermal imaging camera. The heat generator must be switched on to do this.

⚠ The 2/3-way valve kit set for 3-way operation must be installed in the case of systems with series connection. Otherwise, when one unit stops, the units installed downstream will shut down due to lack of flow.

5. PRE-INSTALLATION

In the case of upgrading, before installing the Aquarea Loop units the following steps are required:

- Existing system survey
- Removal of previously installed terminals

- Flushing the system

⚠ Always perform these steps before proceeding with the installation of the units Aquarea Loop.

5.1 Existing system survey

Different types of installations can be encountered in upgrading projects, according to system age and design or installation choices.

According to the system type, there may be different critical issues, according to which specific measures will be necessary. Therefore, the existing system survey is very important.

Some of the possible system types are:

- classical columns

- column with internal shaft distribution
- columns with internal manifold distribution
- column with twin-pipe type internal distribution
- column with single-pipe type internal distribution

⚠ It is possible to find situations with mixed types of system distribution on the same installation. Pay particular attention when surveying the installation.

5.1.1 Classic column system

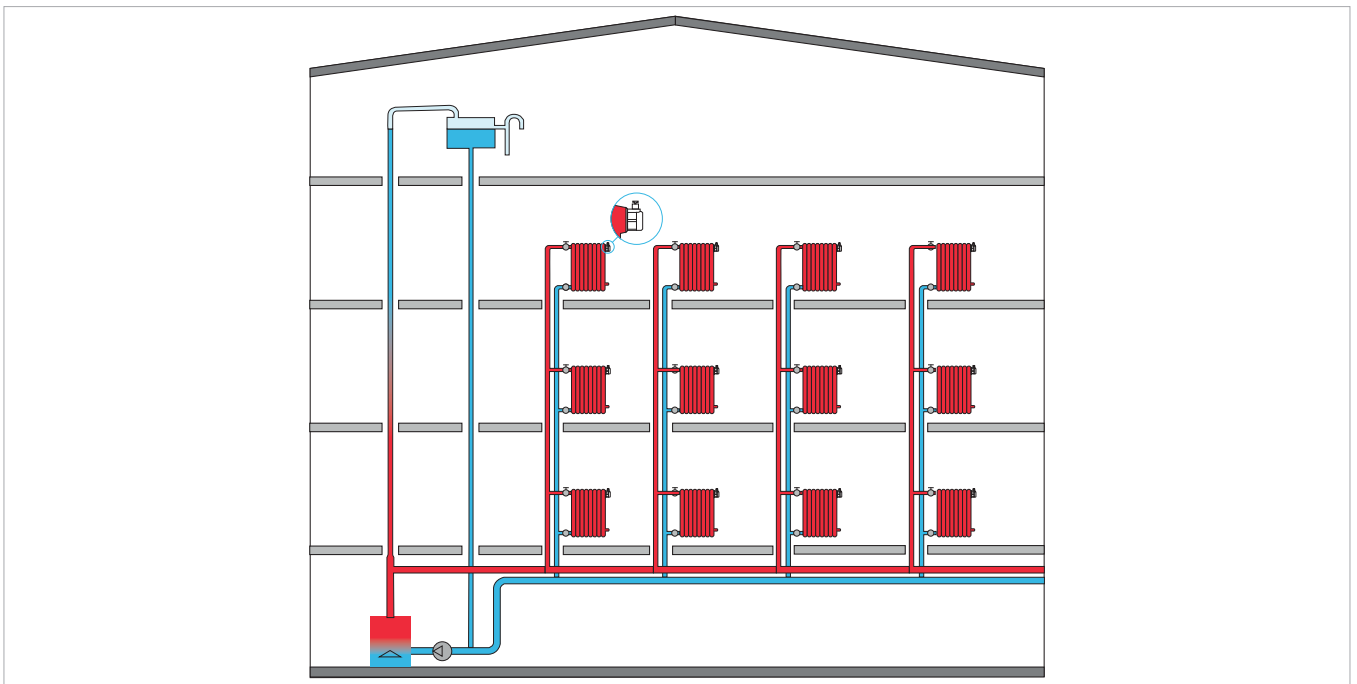

⚠ It is possible to find situations with mixed types of system distribution on the same installation. Pay particular attention when surveying the installation.

Limits and precautions

Pipe material condition and type:

- the condition of existing pipes and the material of which they are made must be taken into consideration to prevent corrosion and deterioration problems that could compromise system efficiency

Diameter of columns in relation to the number of terminals:

- the number of terminals determines the water flow rate in the column. Check the pressure drop as a function of the column diameter and the adequacy of the pump

Configuration

2/3-way modulating valve kit:

- 2/3 way setting (indifferent)
- 2-way setting is recommended to reduce the energy consumed by the circulation pump

5.1.2 Column system with internal shaft distribution

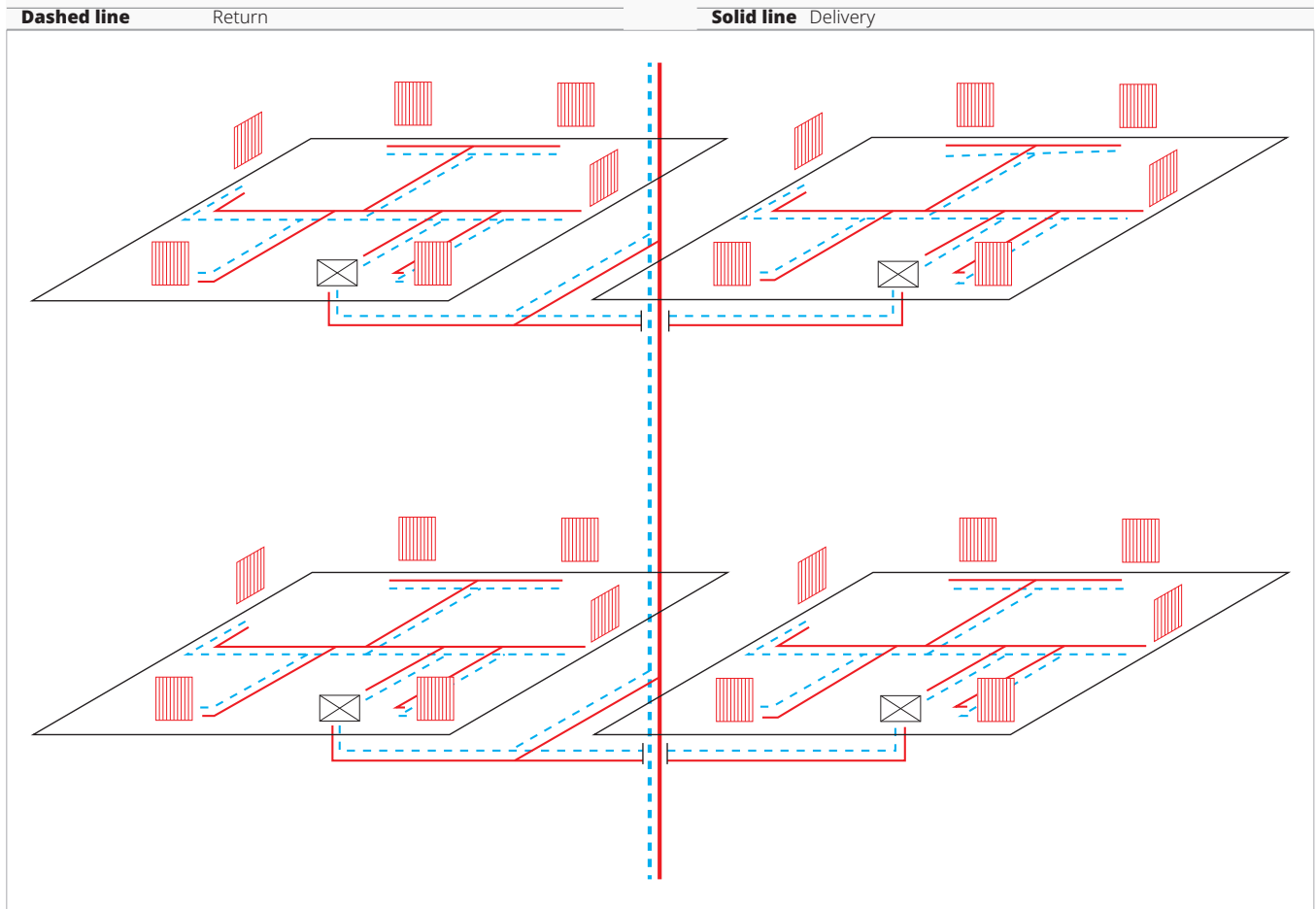

⚠ It is possible to find situations with mixed types of system distribution on the same installation. Pay particular attention when surveying the installation.

Limits and precautions

Pipe material condition and type:

- the condition of existing pipes and the material of which they are made must be taken into consideration to prevent corrosion and deterioration problems that could compromise system efficiency

Diameter of columns in relation to the number of terminals:

- the number of terminals determines the water flow rate in the column. Check the pressure drop as a function of the column diameter and the adequacy of the pump

Configuration

2/3-way modulating valve kit:

- 2/3 way setting (indifferent)
- 2-way setting is recommended to reduce the energy consumed by the circulation pump

5.1.3 Column system with internal manifold distribution

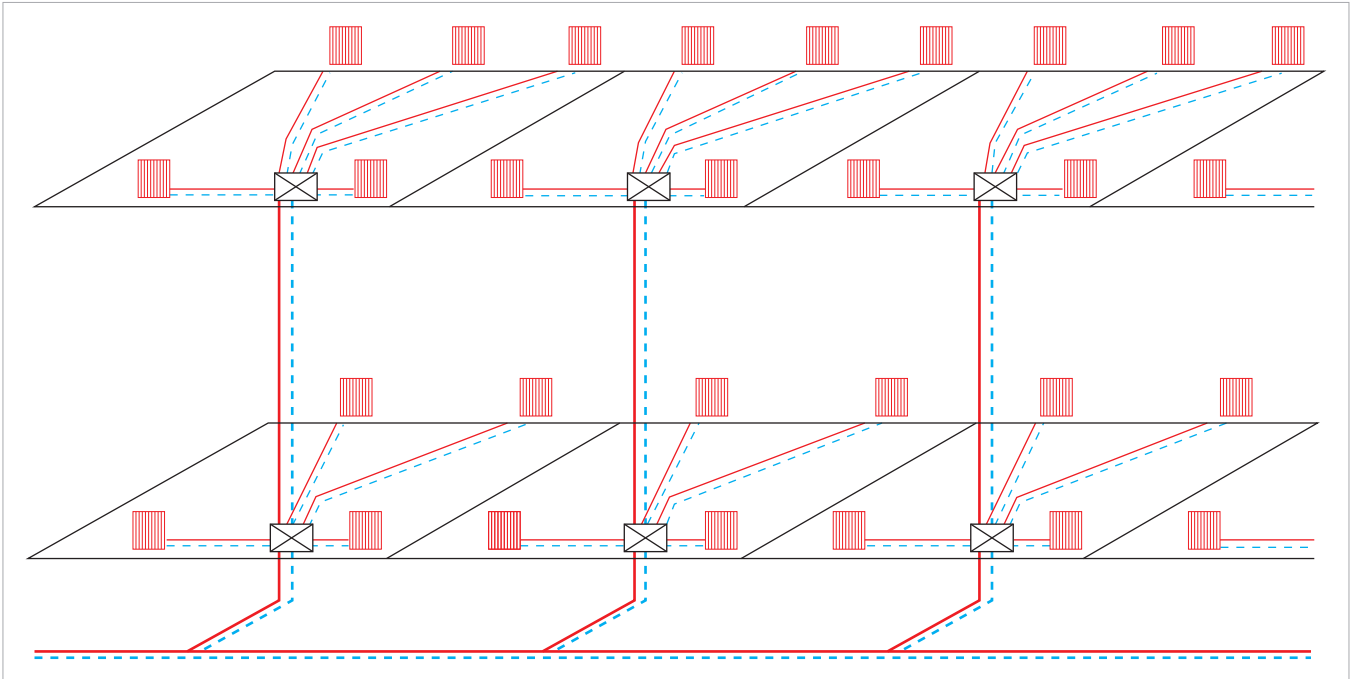

⚠ It is possible to find situations with mixed types of system distribution on the same installation. Pay particular attention when surveying the installation.

Limits and precautions

Pipe material condition and type:

- the condition of existing pipes and the material of which they are made must be taken into consideration to prevent corrosion and deterioration problems that could compromise system efficiency

Diameter of pipes (copper) in relation to the number of terminals:

- it is not advisable to implement the Aquarea Loop system in systems with pipes of 8 mm or less in diameter
- for pipes with diameters of 10 and 12 mm, it is necessary to check the lengths and calculate the pressure drops referring to the range allowable for the Aquarea Loop units that will be installed
- pipes with a diameter of 14 mm or more are generally suitable for upgrading in most cases

Circulation pump selection:

- care must be taken when choosing the circulation pump to ensure system efficiency

Configuration

2/3-way modulating valve kit:

- 2/3 way setting (indifferent)
- 2-way setting is recommended to reduce the energy consumed by the circulation pump

5.1.4 Column system with twin-pipe type internal distribution

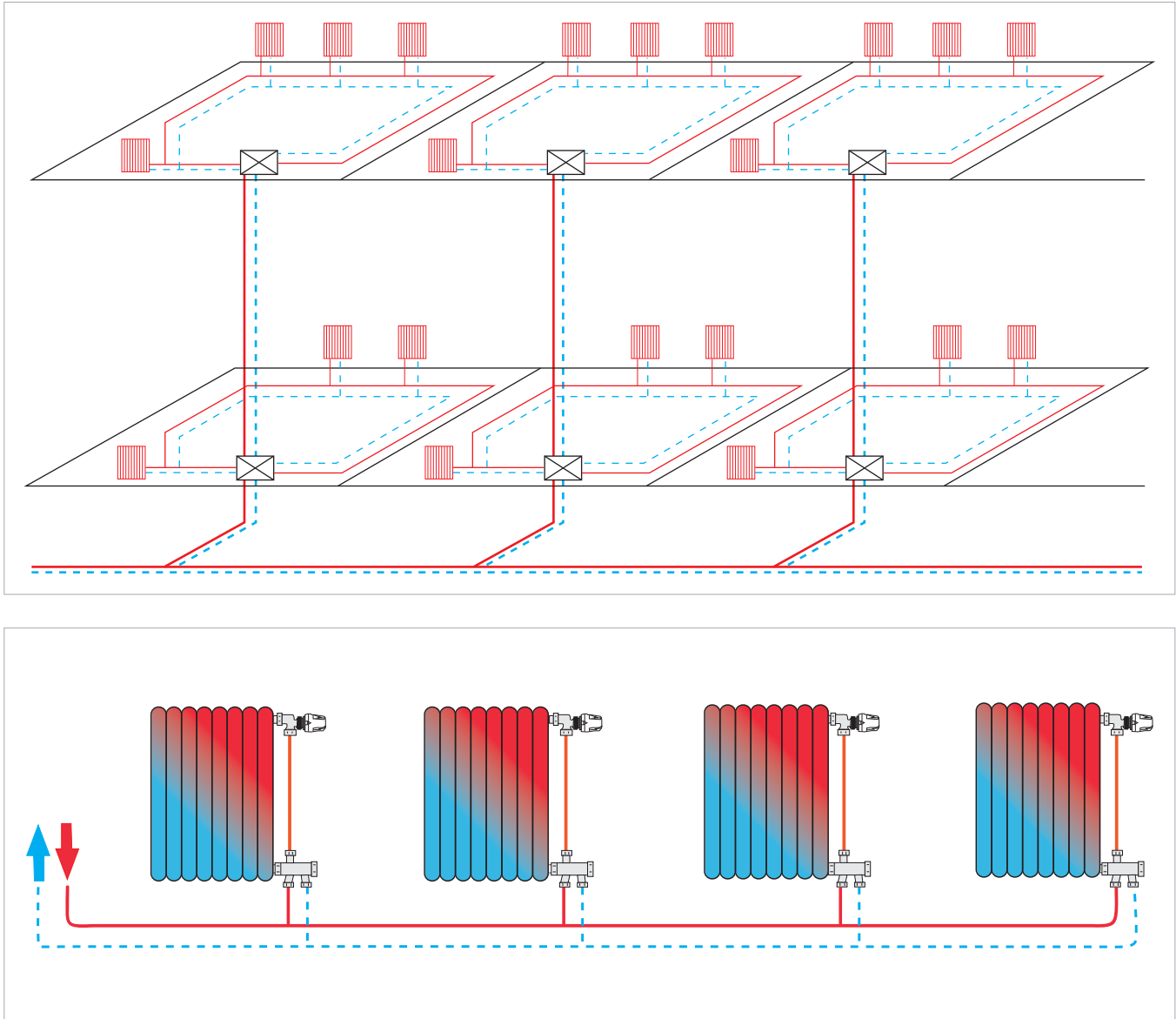

⚠ It is possible to find situations with mixed types of system distribution on the same installation. Pay particular attention when surveying the installation.

Limits and precautions

Pipe material condition and type:

- the condition of existing pipes and the material of which they are made must be taken into consideration to prevent corrosion and deterioration problems that could compromise system efficiency

Diameter of pipes (copper) in relation to the number of terminals:

- it is not advisable to implement the Aquarea Loop system in systems with pipes of 8 mm or less in diameter
- for pipes with diameters of 10 and 12 mm, it is necessary to check the lengths and calculate the pressure drops referring to the range allowable for the Aquarea Loop units that will be installed

- pipes with a diameter of 14 mm or more are generally suitable for upgrading in most cases

Circulation pump selection:

- care must be taken when choosing the circulation pump to ensure system efficiency

Configuration

2/3-way modulating valve kit:

- 2/3 way setting (indifferent)
- 2-way setting is recommended to reduce the energy consumed by the circulation pump

5.1.5 Column system with single-pipe type internal distribution

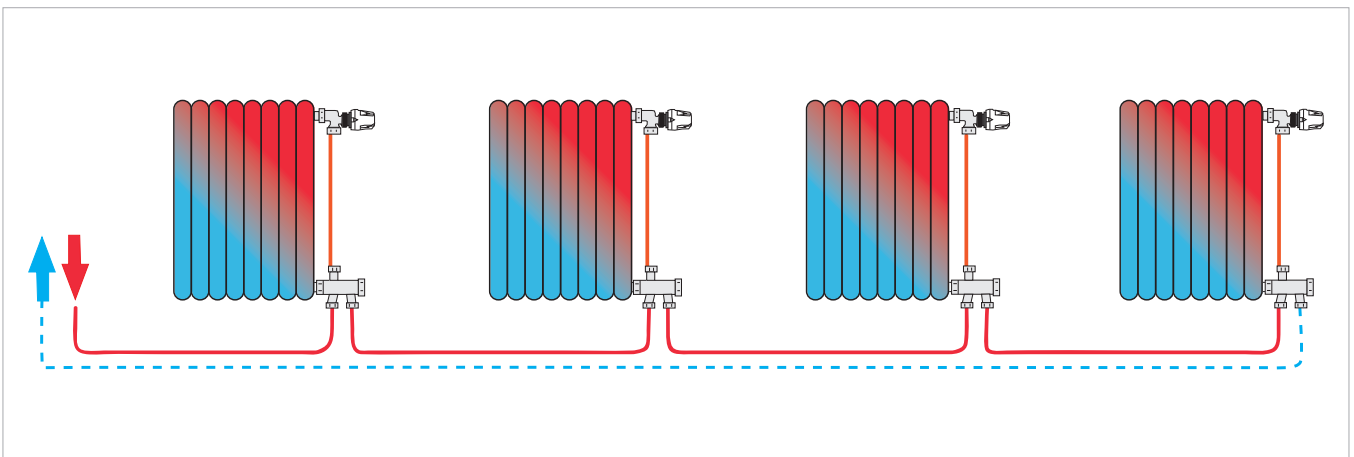
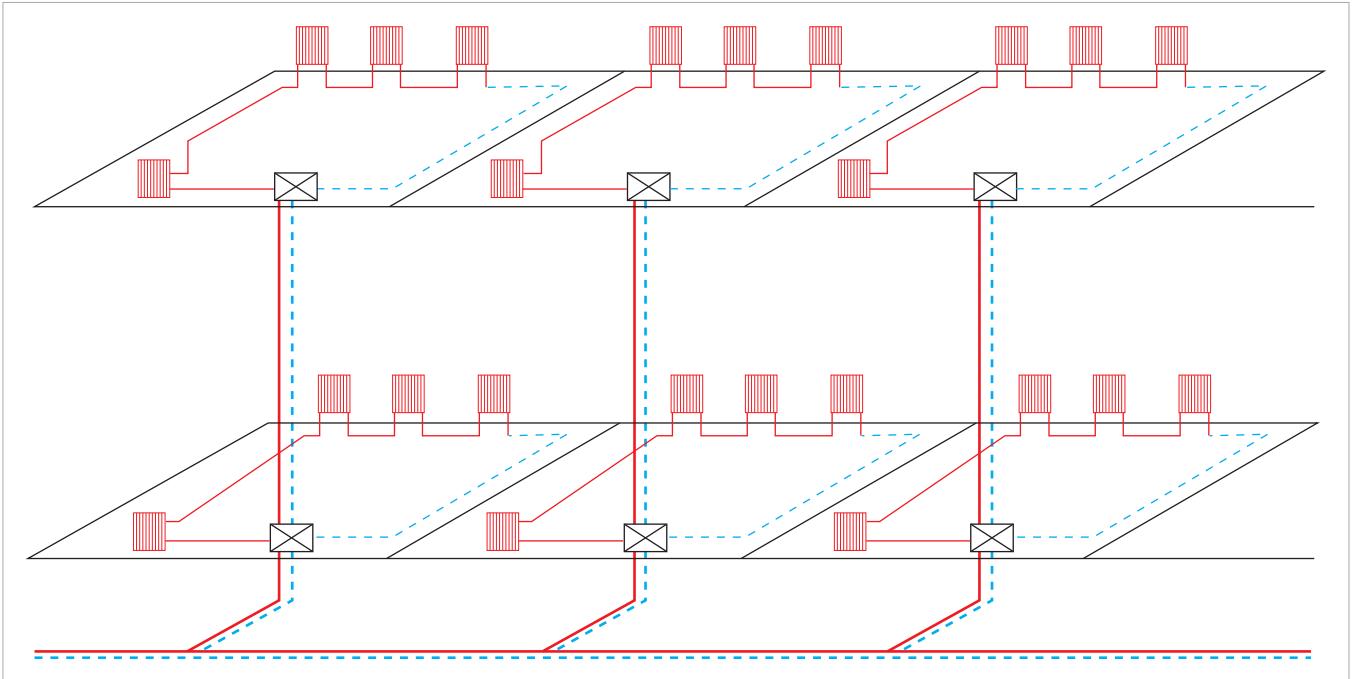

⚠ It is possible to find situations with mixed types of system distribution on the same installation. Pay particular attention when surveying the installation.

Limits and precautions

Pipe material condition and type:

- the condition of existing pipes and the material of which they are made must be taken into consideration to prevent corrosion and deterioration problems that could compromise system efficiency

Number of radiators in the loop:

- the number of radiators affects the loop temperature. Be sure to assess the impact on heat distribution and the overall thermal efficiency of the system

Diameter of pipes (copper) in relation to the number of terminals:

- it is not advisable to implement the Aquarea Loop system in systems with pipes of 8 mm or less in diameter

- for pipes with diameters of 10 and 12 mm, it is necessary to check the lengths and calculate the pressure drops referring to the range allowable for the Aquarea Loop units that will be installed
- pipes with a diameter of 14 mm or more are generally suitable for upgrading in most cases

Circulation pump selection:

- the circulation pump must be chosen carefully to ensure that it meets the flow and pressure requirements of the system. Appropriate choice is crucial for maintaining operational efficiency

Configuration

2/3-way modulating valve kit:

- 3-way setting (mandatory)

5.2 Existing terminal inlet/outlet survey

⚠ Perform the survey before removing previously installed terminals.

▶ mark water inlet/outlet

To survey the existing installation:

▶ identify water inlet/outlet

Current radiators can have multiple connections as shown below.

Possible water inlet and outlet configurations in radiators

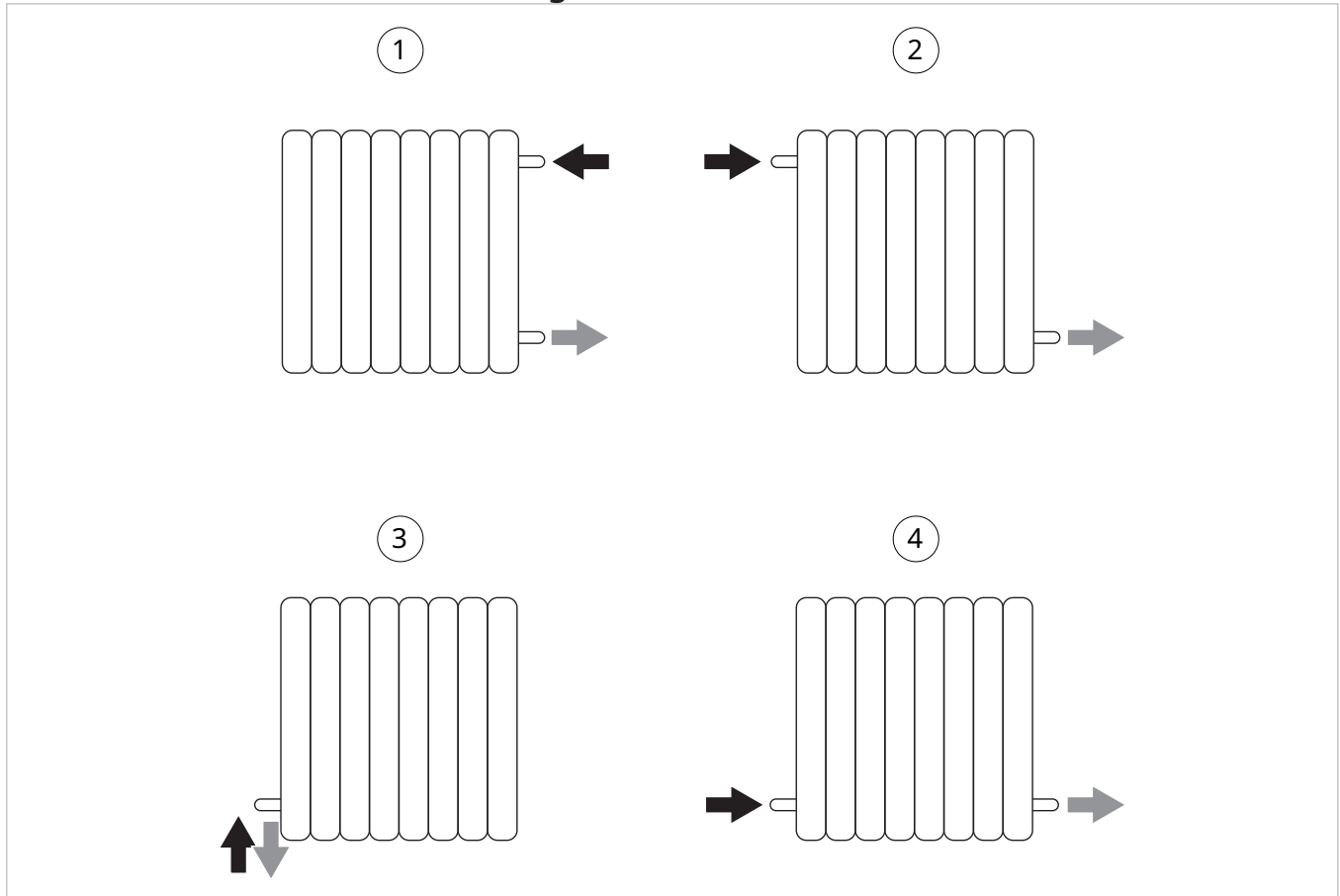

Note that:

- ⚠ Minor masonry work may be required to adapt the connections.
- ⚠ The final position of the attachments is on the lower left.
- ⚠ The condensate drain must be arranged.
- ⚠ A power supply line is required.
- ⚠ The water inlet and outlet positions must be observed.

Attachment position

1. Hydraulic connection passage
2. Condensate drain

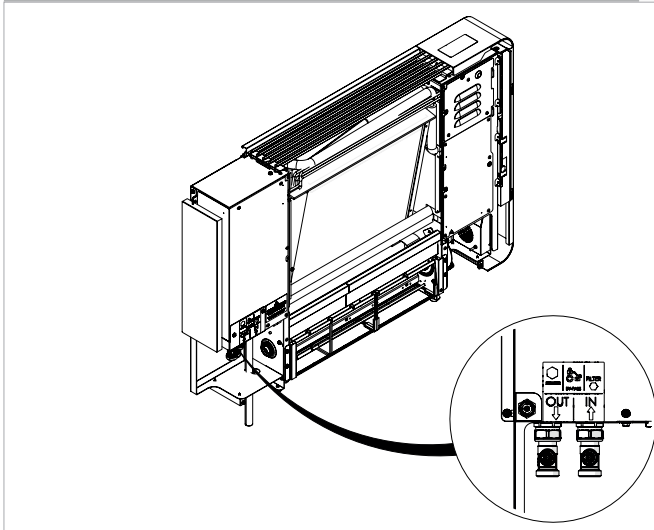

3. Electrical connection passage

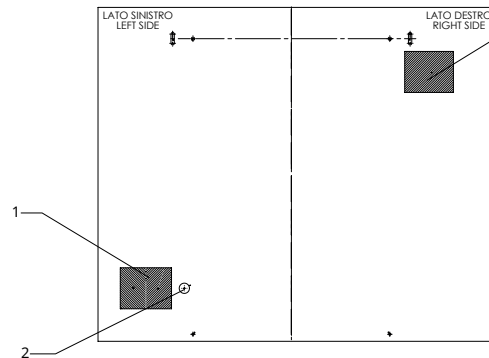

⚠ For dimensional information, refer to chapter "Dimensions" p. 83.

5.3 Removal of previously installed terminals

- ⚠ Always survey the existing system before proceeding.
- ⚠ The pump must be switched off before removing the terminals.
- ⚠ **Installing the Aquarea Loop units only after the system has been flushed.**
- ⊖ It is forbidden to install Aquarea Loop before flushing the system, see chapter "Flushing and washing the system" p. 22.

After surveying the existing installation:

- ▶ switch off the pump

- ▶ remove existing terminals
- ▶ proceed with the masonry and plumbing work to adapt existing connections to the Aquarea Loop.
- ▶ use the installation template for the position of the connections
- ▶ strictly observe the connection inlet and outlet
- ▶ install a temporary by-pass between the input and output of the removed terminal

⚠ In case of doubt about the direction of the water flow, it is recommended to insert a flow indicator.

5.4 Flow indicator

To check water flow:

- ▶ insert a flow indicator in the bypass
- ▶ start the loop pump
- ▶ check that circulation is correct

- | | |
|---------------------------|-------------------|
| 1. Existing system piping | 3. 2-way valve |
| 2. Flexible pipe | 4. Flow indicator |

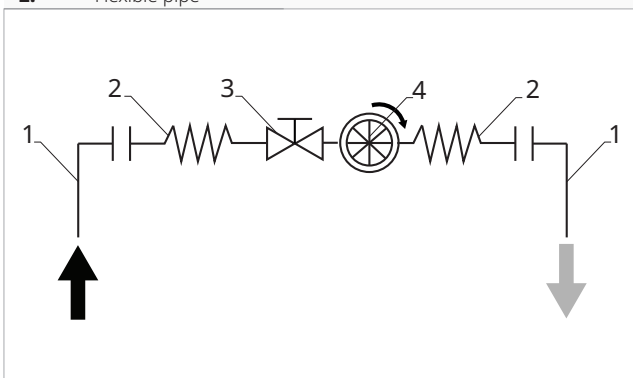

5.5 Flushing and washing the system

5.5.1 Warnings

- ⚠ Check that the existing terminals have been removed.
- ⚠ Check that work has been carried out to adapt the existing connections to those of the Aquarea Loop terminals.
- ⚠ Check that the temporary by-pass has been installed before flushing the system.
- ⚠ It is important to carefully follow the instructions and use the specified tools and chemicals to ensure effective flushing and cleaning of the heating system.

⚠ Measuring the temperature and checking the degree of protection with the GEL inhibitor kit are essential to ensure that the system is properly protected against limescale and corrosion.

5.5.2 Materials and tools needed

- GEL Long Life 800 type heating system cleaning fluid or similar
- GEL Long Life 100 cleaning fluid or similar protective inhibitor for heating systems
- GEL Superflush 40 high circulation cleaning fluid pump or similar
- Accessories for conductivity measurement
- Specific chemicals for system treatment

5.5.3 System preparation

Inhibitor dosing circuit diagram

1. Pulse counter
2. Injection point
3. Autoclave
4. Storage tank

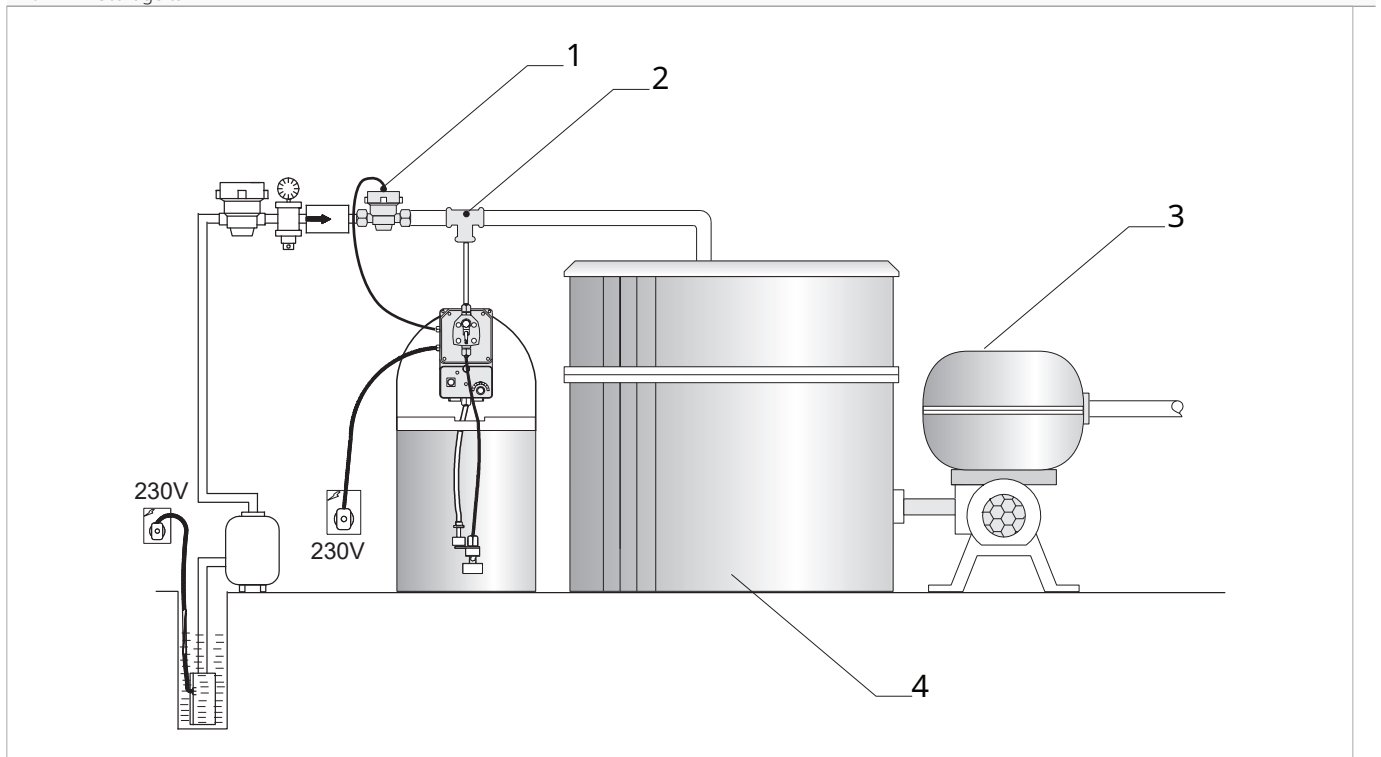

- ▶ set up the inhibitor dosing circuit at the station
 - ▶ empty the system completely
 - ▶ fill with mains water
- ⓘ This operation allows the particles in the water to be removed and, using a litre counter, to know the volume of water contained in the system to dose the products correctly.
- ⚠ Make sure that water can circulate in both directions.

- ▶ open the cock for draining into the sewerage system

5.5.5 Pre-flushing

- ▶ switch on the cleaning fluid pump for a few minutes
- ▶ reverse the flow regularly until the water comes out clear from the drain
- ▶ close the drain
- ▶ close the mains water supply

5.5.4 Pump connection

- ▶ connect the cleaning fluid pump to the system

5.5.6 Treatment with cleaning fluid

- ▶ switch on the cleaning fluid pump

- ▶ add 1 litre of Long Life 800 cleaning fluid for every 100 litres of water in the system
- ▶ measuring conductivity
- ▶ conductivity must increase (with Long Life 800: +1000 μ S)
- ▶ if not, add cleaning fluid again
- ▶ circulate the solution in the system for at least 2-3 hours
- ▶ reverse the flow every 10 minutes

5.5.7 Final flushing

After treatment:

- ▶ open the entire system
- ▶ drain off the flushing liquid and residue until the water is clear
- ▶ fill with clean water
- ▶ measuring conductivity
- ▶ check that the conductivity value is the same as the mains water
- ▶ positioning the closed circuit valves
- ▶ close the drain
- ▶ add the Long Life 100 inhibitor in the same quantity as the cleaning fluid
- ▶ start the pump
- ▶ reverse the flow for a few minutes
- ▶ check the degree of protection with the Inhibitor GEL test kit

⚠ The level of Long Life 100 inhibitor must be checked every year.

⚠ The inhibitor liquid can also be topped up with Long Life 100 FAST spray directly from a filling point (400 ml per 100 litres of water in the system).

5.5.8 Rinsing the system

- ▶ open the entire system
- ▶ rinse until the water is clear and has the same conductivity as mains water

5.5.9 Adjusting the water hardness

- ▶ connect the mobile softener
- ▶ fill the system with softened water
- ▶ check water hardness with the GEL hardness kit

5.5.10 System protection

- ▶ add 0.1% Long Life 100 Pocket inhibitor diluted in water
- ▶ start the pump for a few minutes to distribute the inhibitor
- ▶ check the inhibitor level in the system once a year

6. INSTALLATION

6.1 Preliminary warnings

- ⚠ **For detailed information on the products, refer to chapter "Technical information" p. 81.**
- ⚠ The installation must be carried out by the installer in accordance with national installation regulations. There is a risk of water leakage, electric shock or fire if the installation is not performed correctly.
- ⚠ During the installation, it is necessary to observe the precautions mentioned in this manual, and on the labels placed inside the equipment, as well as to adopt any precaution suggested by common sense and by the Safety Regulations in force in the place of installation.
- ⚠ Be sure to use the supplied or specified installation parts. Use of other parts may cause the unit to come loose, leak water, or cause electrical shock, or fire.
- ⚠ The Manufacturer accepts no liability for damage caused to animals or property due to failure to apply the indicated rules which may cause malfunction of appliances.
- ⚠ Air conditioners without an external unit are designed for indoor installation only.

6.1.1 Preliminary warnings for R290

- ⚠ Safety checks must be carried out to ensure that the risk of combustion is minimised before starting work on systems containing flammable refrigerants.
- ⚠ The appliance must be protected against accidental impacts to prevent mechanical damage.
- ⚠ Do not puncture or burn.

6.2 Reception

6.2.1 Preliminary warnings

- ⚠ On receipt check for any damage and, if any is found, accept the goods with reservation, and keep photographic evidence of any damage found
- ⚠ The package must be transported in an upright position; otherwise, notify the carrier immediately.
- ⚠ In the event of damage, notify the shipper within 3 days of receipt of any damage by registered mail with return receipt, submitting photographic evidence. Similar information should be sent by fax to the manufacturer (jurisdiction will be at the Court Trento for any dispute).
- ⚠ No notice of damage will be accepted after 3 days from delivery.
- ⚠ Unpack and check the contents of individual components against the packing list.

6.2.2 Package description

The packaging is made of suitable material and carried out by experienced personnel.

All units are checked and tested and are delivered complete and in perfect condition.

The appliance is shipped in standard packaging consisting of a cardboard sleeve and a set of expanded polystyrene protectors.

6.3 Dimensions and weights with packaging

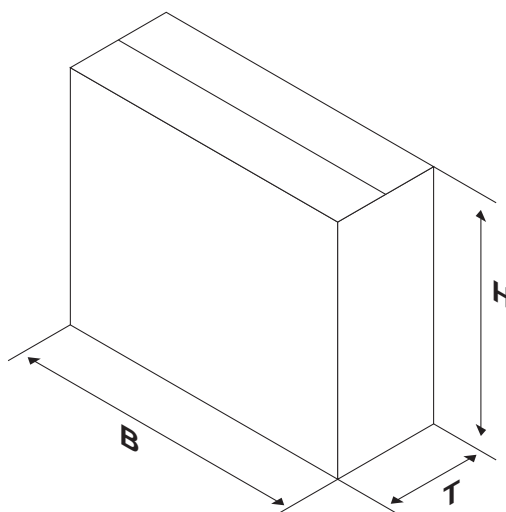

Models	u.m.	10	20	30
Dimensions and weight for shipping				
Width	mm	850	1050	1250
Height	mm	750	750	750
Total depth	mm	260	260	260
Weight	kg	38,0	43,0	48,0

6.4 Handling with packaging

6.4.1 Preliminary warnings

- ⚠ The appliance must be handled only by qualified personnel, adequately equipped and with equipment suitable for the weight and dimensions of the appliance.
- ⚠ Stay clear of the area below and around it when the load is lifted off the ground.
- ⚠ Avoid dangerous situations when using a hoist to lift the appliance.
- ⚠ During transportation, the unit must be kept in vertical position.

6.4.2 Movement methods

Boxes can either be carried singularly by hand by two operators or loaded on a forklift truck evenly stacked.

- ⚠ Check the indications on the packaging for the number of packages that may be stacked together.
- ⚠ In manual operation it is compulsory to always respect the maximum weight per person provided for by the national laws and standards.
- ⚠ Use the handles provided on the packaging.

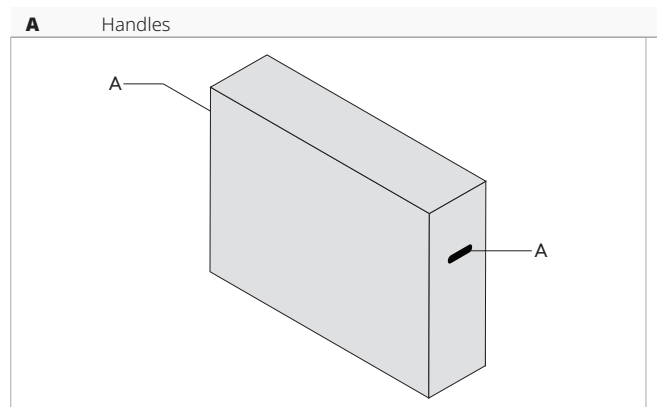

6.5 Storage

6.5.1 Preliminary warnings

- ⚠ Store in accordance with the applicable national regulations.
- ⚠ Store the box in a closed environment protected from atmospheric agents and isolate it from the floor using planks or pallets.
- ⚠ Do not turn the packaging upside down.
- ⚠ Only place the appliance in a vertical position.

⚠ Store in a clean and dry place.

Specific warnings for R290

- ⚠ Store the unit in such a way as to avoid mechanical damage.
- ⚠ Check current national/local fire regulations. The refrigerant contributes to the fire load (149 g R290).

6.6 Unpacking

6.6.1 Preliminary warnings

- ⚠ Check that no components were damaged during transport.
- ⚠ Dispose of the packaging components following the applicable waste disposal regulations. Check for disposal arrangements with your municipality.
- ⚠ Handle with care.
- ⚠ The equipment must always be handled vertically.
- ⚠ Check if there is refrigerant inside the package using an electronic leak detector suitable for the system refrigerant. If it is present, the refrigeration circuit is likely damaged. In this case, do not install the appliance and call the Authorised Service Centre.

⊖ The packing material (cardboard, staples, plastic bags, etc.) must not be dispersed or abandoned in the surrounding environment and must be kept out of the reach of children, as it poses a risk of danger.

Specific warnings for R290

- ⚠ Check that there are no sources of ignition in continuous operation (open flames, gas appliances, electric stoves, lighted cigarettes, etc.).
- ⊖ Using leak detectors with halogen lamps is prohibited.
- ⊖ Smoking in the vicinity of the appliance is prohibited.
- ⊖ Using a mobile phone near the appliance is prohibited.

6.6.2 Remove the package

1. Polystyrene elements

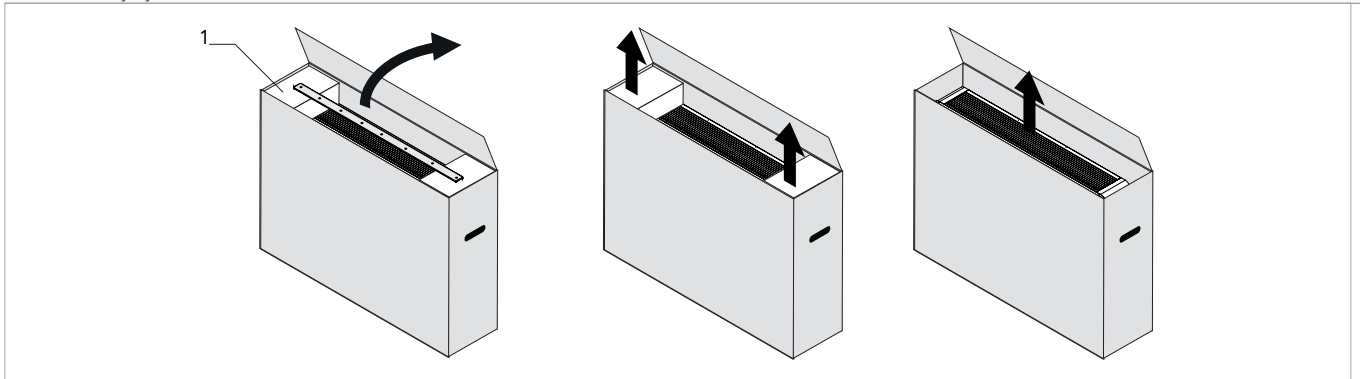

Remove the packing:

- ▶ open the cardboard packaging
- ▶ remove the wall-fixing bracket
- ▶ remove the accompanying components
- ▶ remove the polystyrene elements
- ▶ remove the appliance from the box

- 1 instruction sheet for downloading the manuals
- 1 label for scanning the QR Code
- 1 paper template
- One Energy efficiency label

Accompanying material

They are included with the appliance, inside the packaging:

- ⚠ Check the presence of the individual components.
 - 1 wall mounting bracket

6.7 Handling without packaging

6.7.1 Preliminary warnings

- ⚠ The appliance must be handled only by qualified personnel, adequately equipped and with equipment suitable for the weight and dimensions of the appliance.
- ⚠ The appliance is unbalanced on the right (compressor side)

6.8 Installation site

The location of the appliance must be determined by the plant engineer or a competent person and must take into account both purely technical requirements and any national/local legislation in force.

The appliance is intended to be installed indoors in a vertical, low-wall position.

- ⚠ The appliance is stated as having an IPX0 protection rating, therefore it is not suitable for outdoor installation and in rooms with high levels of humidity (swimming pool rooms, etc.).
- ⚠ The unit can be installed at a maximum altitude of 2700 m.

6.8.1 Preliminary warnings

- ⚠ Avoid installing the unit near:
 - obstacles or barriers that cause recirculation of the exhaust air
 - narrow places where the sound level of the appliance can be enhanced by reverberations or resonances
 - environments with the presence of flammable or explosive gases
 - very humid environments (laundries, greenhouses, etc.)
 - environments with aggressive atmospheres
 - solar radiation and proximity to heat sources
- ⚠ Avoid placing the unit within 1 metre of radio and video equipment.
- ⚠ Do not install over heat sources.
- ⚠ Make sure that:
 - the installation site of the unit must be chosen with the utmost care to guarantee adequate protection from shocks and consequent damage
 - the supporting structure is able to support the weight of the appliance
 - the supporting structure section does not feature building supporting elements, pipes or power lines
 - there are no obstacles to the free circulation of air
 - the appliance must be installed in a position where it can be easily serviced
 - the safety distances between the units and other appliances or structures are scrupulously respected so that the air entering and leaving the fans is free to circulate
- ⚠ If the appliance is installed incompletely or on an inappropriate base, it could cause damage to persons or property if it should detach from its base.

6.7.2 Movement methods

- ⚠ The unit can be moved manually for short distances. In this case it is necessary to check carefully that the weight of the unit does not exceed the regulations in relation to the number of people used.

- ⚠ The unit should not be installed in a position where the air flow is aimed directly at the people nearby.

- ⚠ Provide the following:
 - a nearby drain for the outflow of condensate
 - a compliant power supply nearby
 - fixing elements suitable for the type of support

Specific warnings for R290

- ⚠ The installation of the unit does not have any special requirements (such as minimum area, room ventilation requirements or sensors) in relation to the use of refrigerants as the quantity used is less than 149 gr.

6.9 Installation minimum distances

The clearance zones for the installation and maintenance of the appliance are shown in the figure. Established spaces are necessary to avoid barriers to airflow and allow for normal cleaning and maintenance.

⚠ Make sure that there is sufficient space to allow the panels to be removed for routine and supplementary maintenance operations.

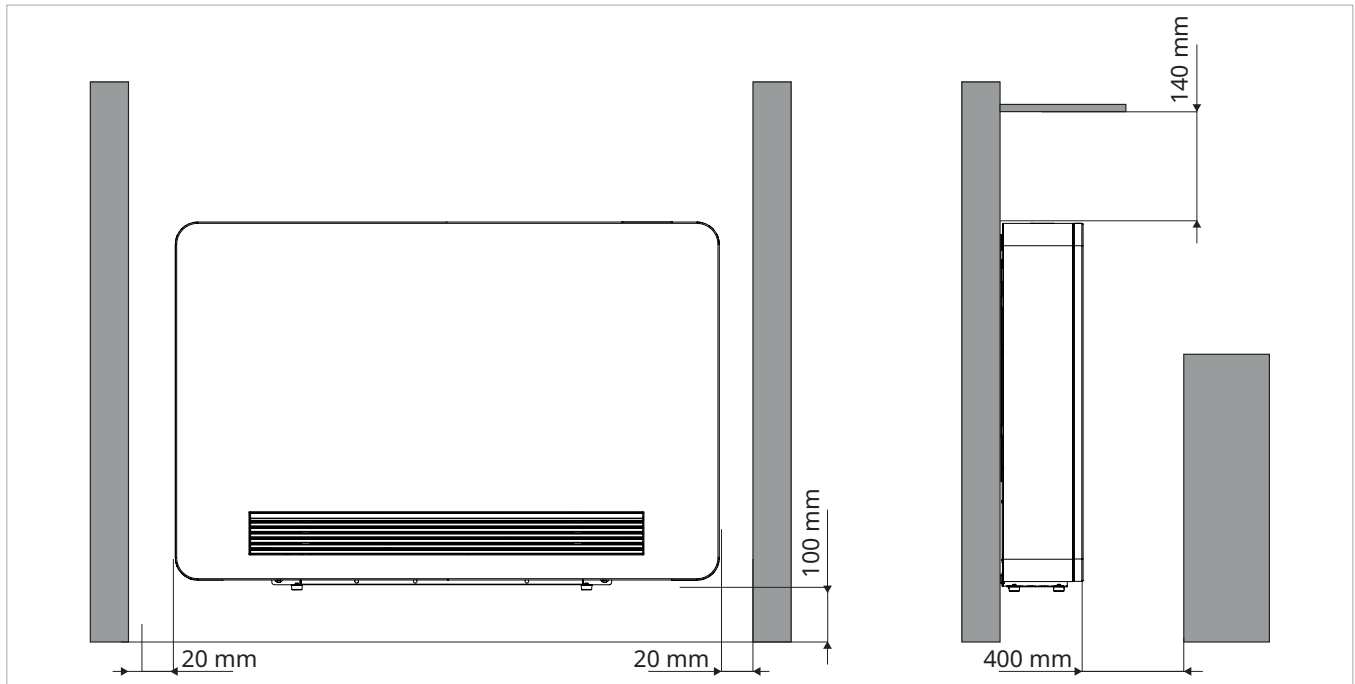

6.10 Positioning

6.10.1 Preliminary warnings

- ⚠** The unit requires two or more people to position the unit.
- ⚠** Ensure that:
 - the wall supports the weight of the appliance
 - the section of the wall does not contain piping or electrical lines
 - the functionality of load-bearing elements is not compromised

6.10.2 Device preparation

Before proceeding with the installation, it is necessary to remove some elements from the appliance.

Removal of upper grille

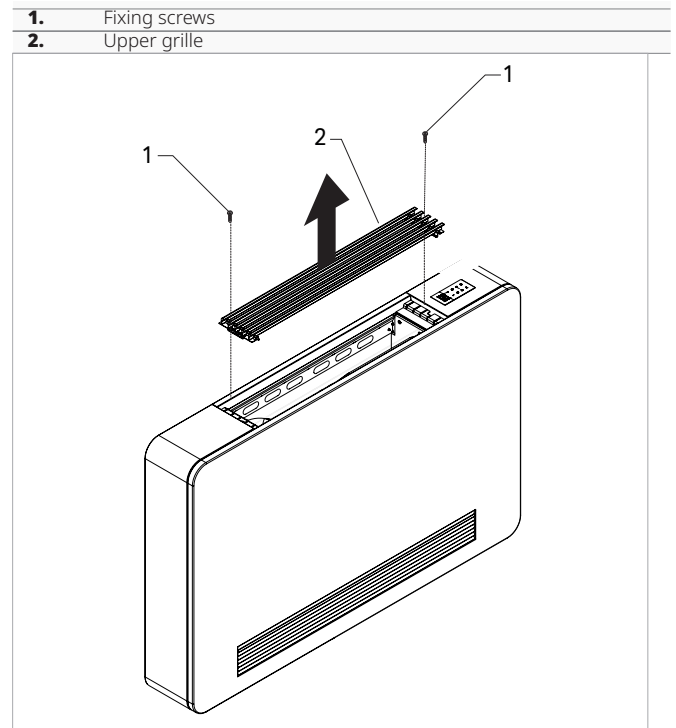

- ▶ remove the fixing screws
- ▶ lift up and remove the upper grille

Front panel removal

1. Fixing screws
2. Front panel

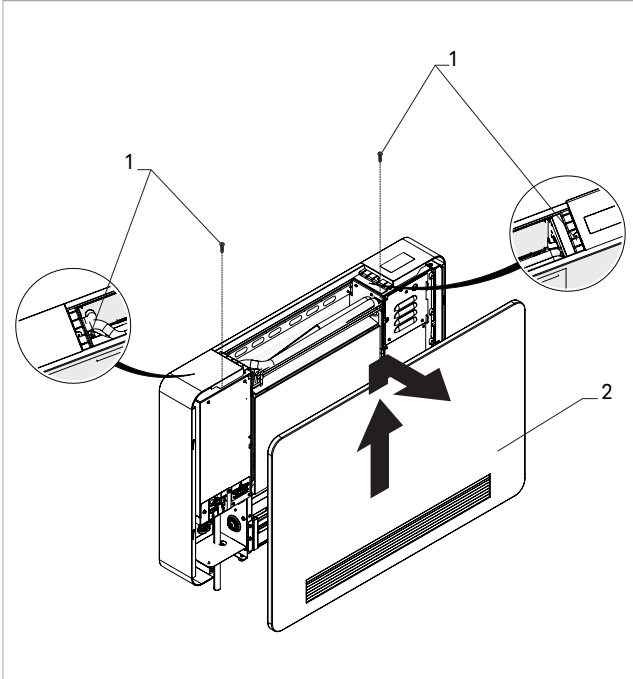

- ▶ remove the fixing screws
- ▶ lift the front panel slightly
- ▶ remove the aesthetic front panel

Removal of the side cover panel on the hydraulic connection side

Remove the side cover panel to facilitate hydraulic connections and avoid damage.

1. Fixing screws
2. Aesthetic side panel

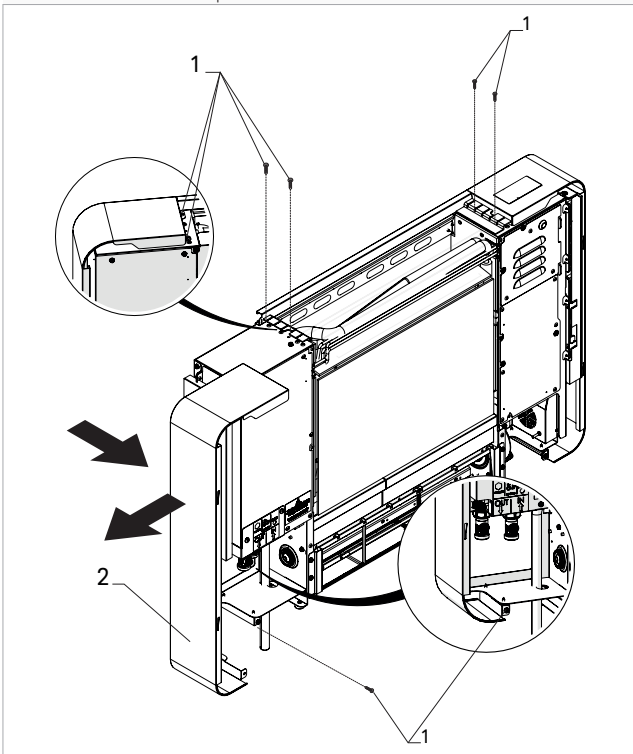

- ▶ remove the fixing screws
- ▶ pull the side panel towards you
- ▶ remove the side panel laterally

6.10.3 Positioning the device

⚠ The units are supplied with a paper template for marking the holes necessary for installation.

1. Hydraulic connection passage
2. Condensate drain
3. Electrical connection passage

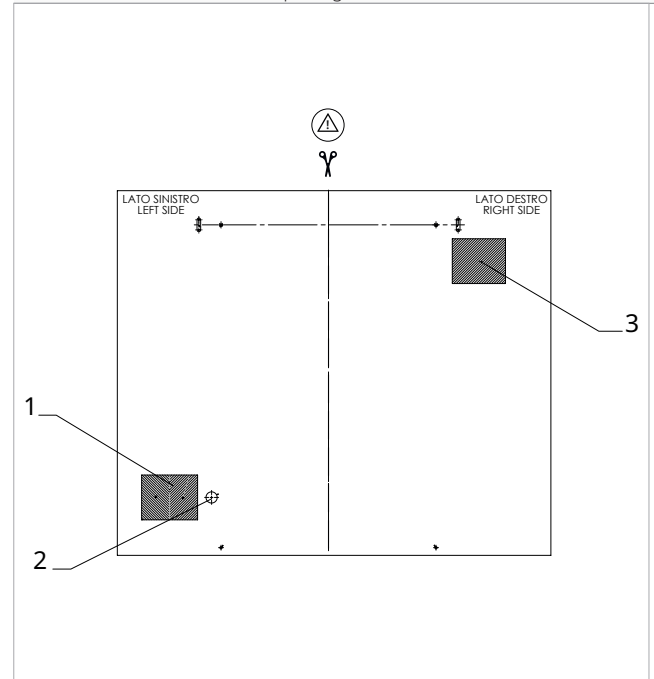

- ▶ use the paper template supplied with the device
- ▶ trace the position of the fixing brackets
- ▶ drill holes in the wall

⚠ Hold the template in the correct position with tape.

⚠ The template is unique for sizes 10 and 20. For size 20, it is necessary to cut the template according to the instructions on the template.

6. INSTALLATION

1. Plugs
2. Fixing bracket

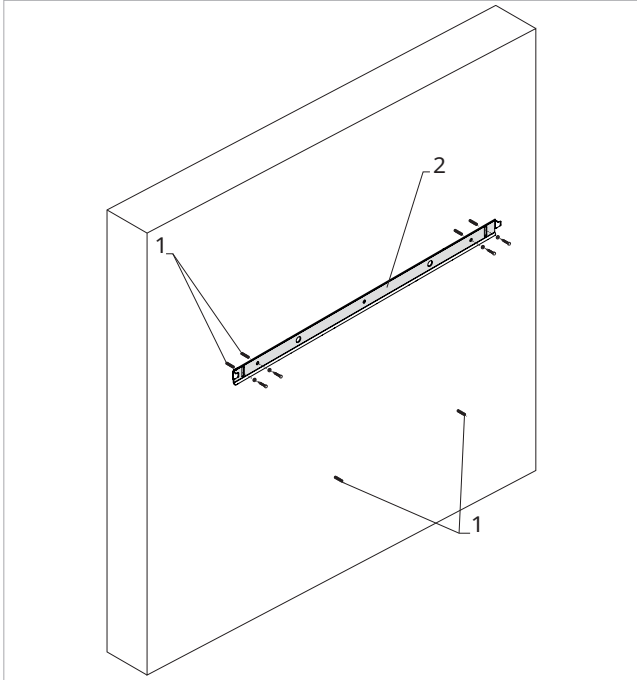

- ▶ insert the expansion plugs
- ▶ position the support brackets
- ▶ partially secure the screws

⚠ Do not fully secure the screws so that you can adjust the position of the appliance.

⚠ Use expansion plugs suitable for the chosen supporting structure.

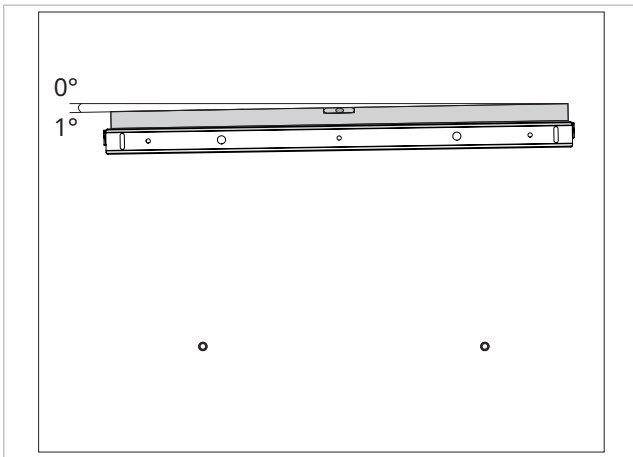

- ▶ use a level
- ▶ check the inclination towards the attachment side
- ▶ secure the screws

⚠ A maximum inclination of 1° towards the left side of the appliance is allowed to facilitate the drainage of condensate.

1. Fixing brackets
2. Unit
3. Lower fixing screws

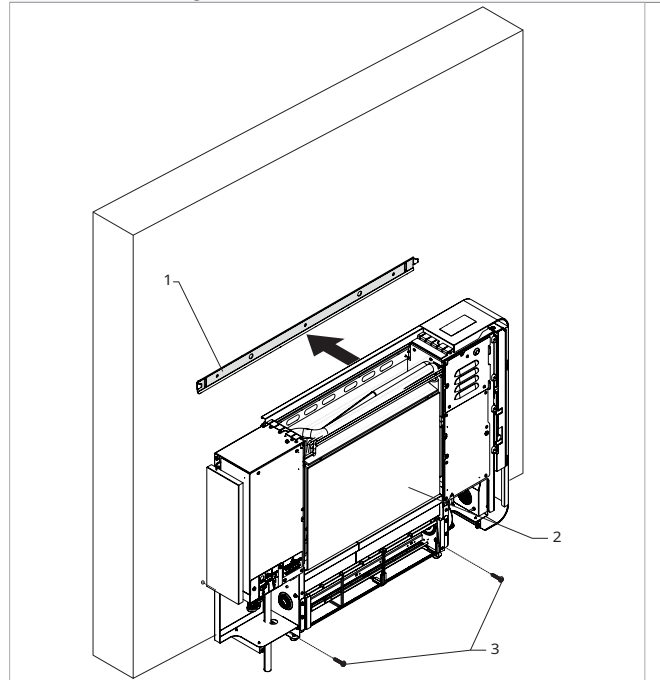

- ▶ hang the appliance from the bracket coupling
- ▶ check the correct attachment to the fixing bracket
- ▶ secure the unit with the lower fixing screws

⚠ **The unit must be secured with the fixing screws to avoid problems during operation.**

6.11 Condensation drain preparation

6.11.1 Preliminary warnings

- ⚠ This appliance is complete with a tray for collecting the condensation produced during operation, which must be channelled to a suitable place for drainage.
- ⚠ Use the installation template to properly position the condensate drain pipe inlet flush with the wall.
- ⚠ The hole for the condensation pipe must always slope towards the outside.
- ⚠ When connecting, take great care to avoid crushing the condensate drain pipe.
- ⚠ If the appliance is used for heating only, the condensate drain is not necessary. In this case, plug the drain connection.

If draining into the sewage system:

- ⚠ Make a siphon to prevent bad smells returning up the pipe towards the room. The curve of the siphon must be lower than the condensation collection pan.
- ⚠ The syphon must feature a plug in its lower part or must otherwise allow for quick disassembly for cleaning purposes.

If using an open drain:

- ⚠ Drain the condensate liquid flow directly onto a gutter or into a "grey water" drain
- ⚠ If the condensation is not collected, it will be deposited on the support surface. The water could freeze if the outdoor temperatures are below zero, thus creating a hazard. In this case, appropriate barriers should be installed in order to prevent people from approaching the area.

If a condensate drain cannot be made:

- ⚠ An appliance complete with condensate injection kit must be ordered.
- ⚠ The condensate injection kit must be fitted at the factory. It is not possible to fit the condensate injection kit following installation of the appliance.

6.11.2 Condensate drain dimensions

Models	u.m.	10	20	30
Condensate drain connection	mm	16	16	16

6.11.3 Connection

1. Liquid drain pipe

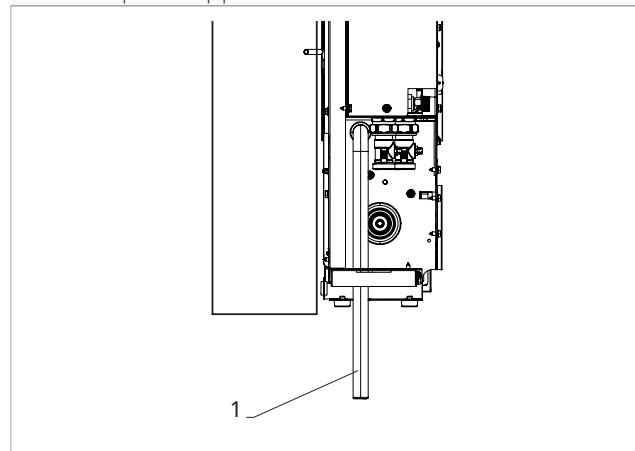

- ▶ connect the condensate drain pipe to the condensate drain connection
- ▶ direct the liquid drain pipe towards a suitable location for drainage
- ▶ keep a slope of 3% towards the drain location
- ▶ insulate fitting points

- ⚠ Check that the drop-break extension is present and properly installed.

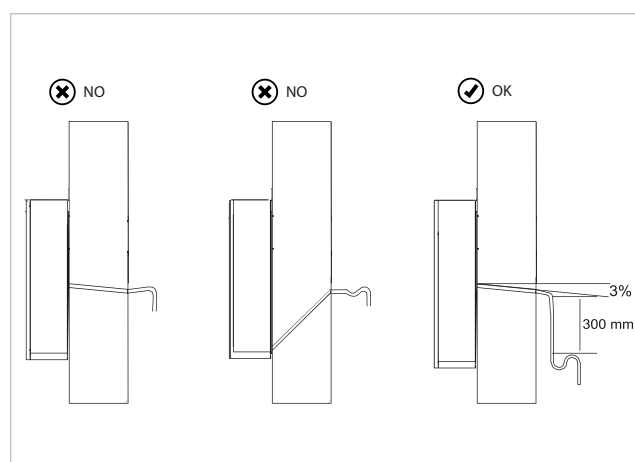

- ⚠ Pay attention to the angle of the condensate drain pipe.
- ⚠ Use plastic drainage pipes.
- ⚠ Avoid pipes made of metallic material.
- ⚠ Make sure all joints are sealed to prevent leakage of water.
- ⚠ Condensate drainage pipes must be insulated for both indoor and outdoor sections of the house to avoid condensation on the surface and/or freezing problems.
- ⚠ When mounting the pump, for vertical installations, the pump should be mounted under the side drain pan.

6.11.4 Check

Make sure that:

- the unit is installed perfectly level, or with a slight slope in the direction of condensate drainage

After the installation is completed:

- ▶ pour water very slowly into the condensate drain pan
- ▶ check for correct condensate drainage

6.12 Hydraulic connections

6.12.1 Preliminary warnings

- ⚠ The engineer is responsible for choosing the right water lines and their size, in accordance with good installation practices and the applicable law.
- ⚠ The hydraulic system is made by the installer and must be carried out with reference to the diagrams in this manual or on the website.
- ⚠ The hydraulic pipes connecting to the appliance must be suitably sized for the actual water flow required by the system in operation.
- ⚠ Undersized pipelines lead to poor system operation and/or a loss of thermal and cooling performance.
- ⚠ If the existing radiators are replaced, the size of the hydraulic lines must always be checked by a skilled designer.

⚠ Perform the following checks:

Pipe material condition and type:

- the condition of existing pipes and the material of which they are made must be taken into consideration to prevent corrosion and deterioration problems that could compromise system efficiency

Diameter of pipes (copper) in relation to the number of terminals:

- it is not advisable to implement the Aquarea Loop in systems with pipes of 8 mm or less in diameter
- for pipes with diameters of 10 and 12 mm, it is necessary to check the lengths and calculate the pressure drops referring to the range allowable for the Aquarea Loop units that will be installed
- pipes with a diameter of 14 mm or more are generally suitable for upgrading in most cases

Circulation pump selection:

- care must be taken when choosing the circulation pump to ensure system efficiency

6.12.2 Basic hydraulic scheme

A	Hydraulic loop diagram	6.	Flexible connections	13.	Plant drain cock
1.	Heat pump	7.	Antifreeze valve	14.	Automatic plant filling assembly
2.	Plant	8.	Shut-off cocks	15.	Buffer tank
3.	Flow switch (differential pressure switch)	9.	Condensate drainage kit (accessory)	16.	Automatic venting
4.	Electric heating element (accessory)	10.	Expansion vessel	17.	Main manifold
5.	Primary circulation pump	11.	3-bar safety valve	18.	Connective terminal manifold
		12.	Sludge filter	19.	Aquarea Loop
				20.	2/3-way valve kit (optional)

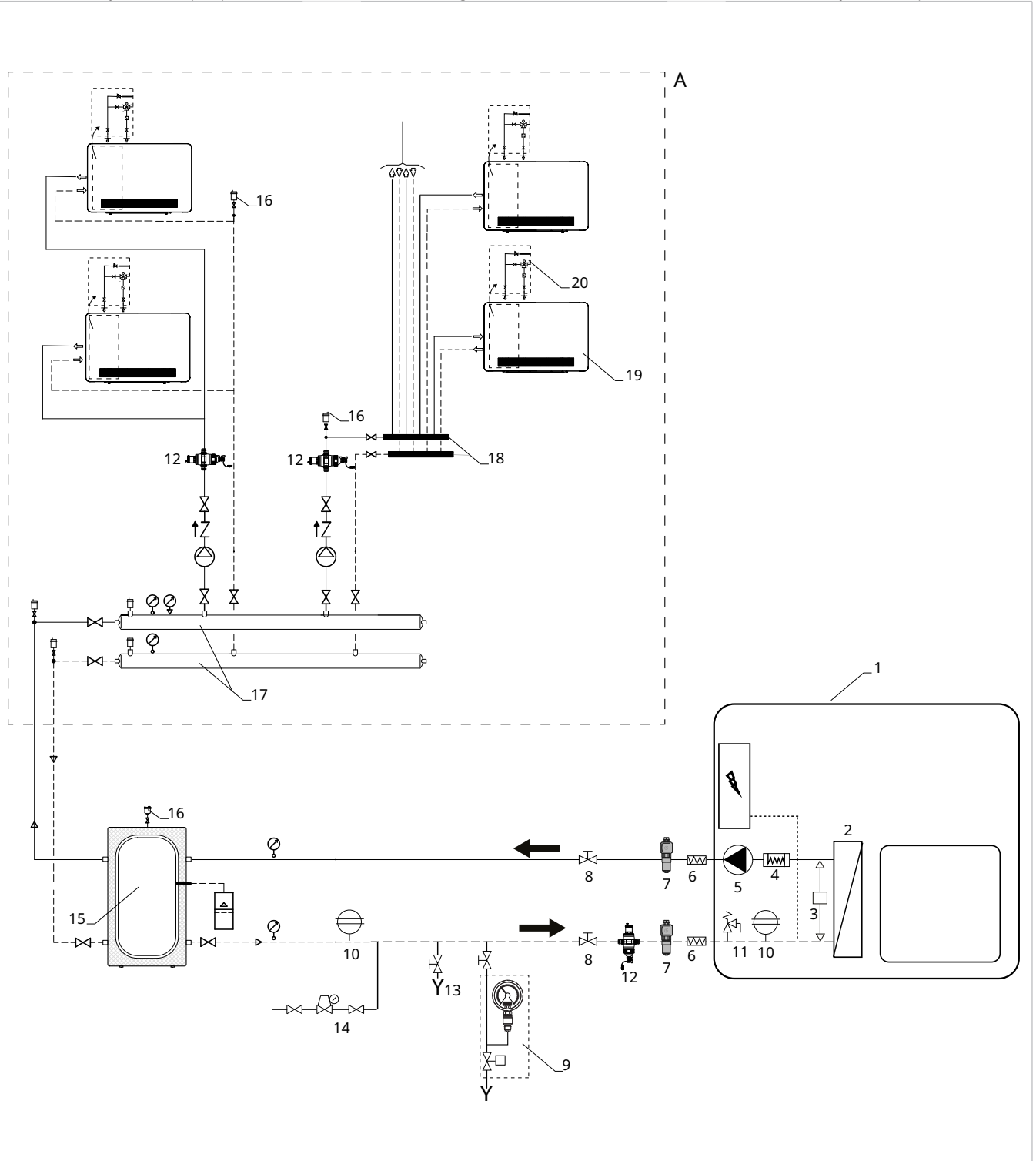

6.12.3 Position and dimensions

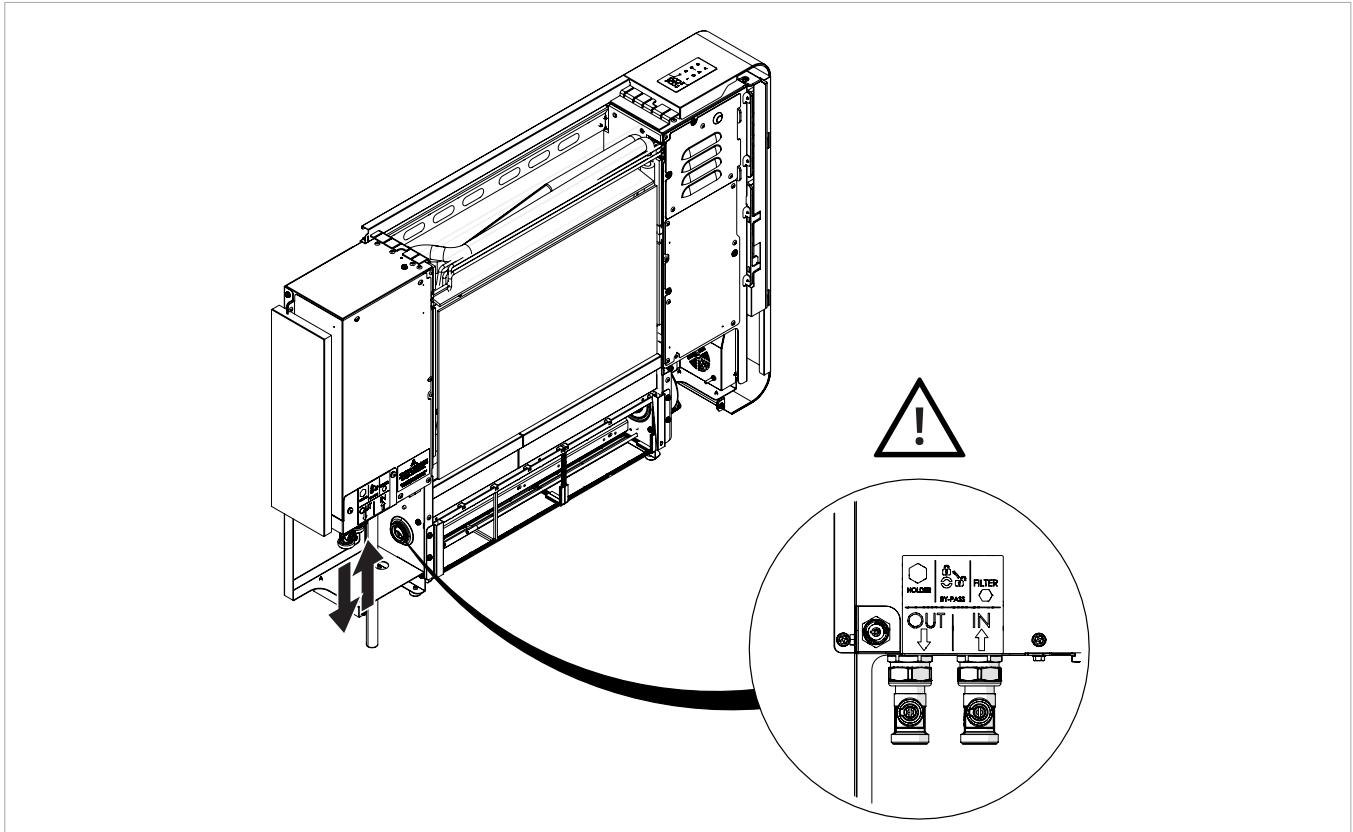

⚠ The water inlet and outlet positions must be observed.

Models	u.m.	10	20	30
Hydraulic connections	" EK	3/4	3/4	3/4

⚠ For dimensional information, refer to chapter "Technical information" p. 81.

- ▶ tighten the connections
- ▶ check for leaks

Only when installing in particularly humid environments:

- ▶ insulate the pipe sections connecting to the unit

6.12.4 System connection

To make the connections:

- ▶ use flexible couplings

6.12.5 Hydronic kits

The unit must be supplied with one of the following hydraulic kits:

- None
- 3-way modulating valve kit

ⓘ The position of the hydraulic connections does not change when the hydronic kit is installed.

⚠ For detailed information on accessories please refer to the "Configuration accessories" p. 78 section.

2-3 way valve setting

A	2-way valve setting (by-pass closed - default setting)
B	2/3-way valve setting (open by-pass)
C	N650423B - 2-way
D	N650423C - 3-way
1.	Holder
2.	Valve and vent access panel

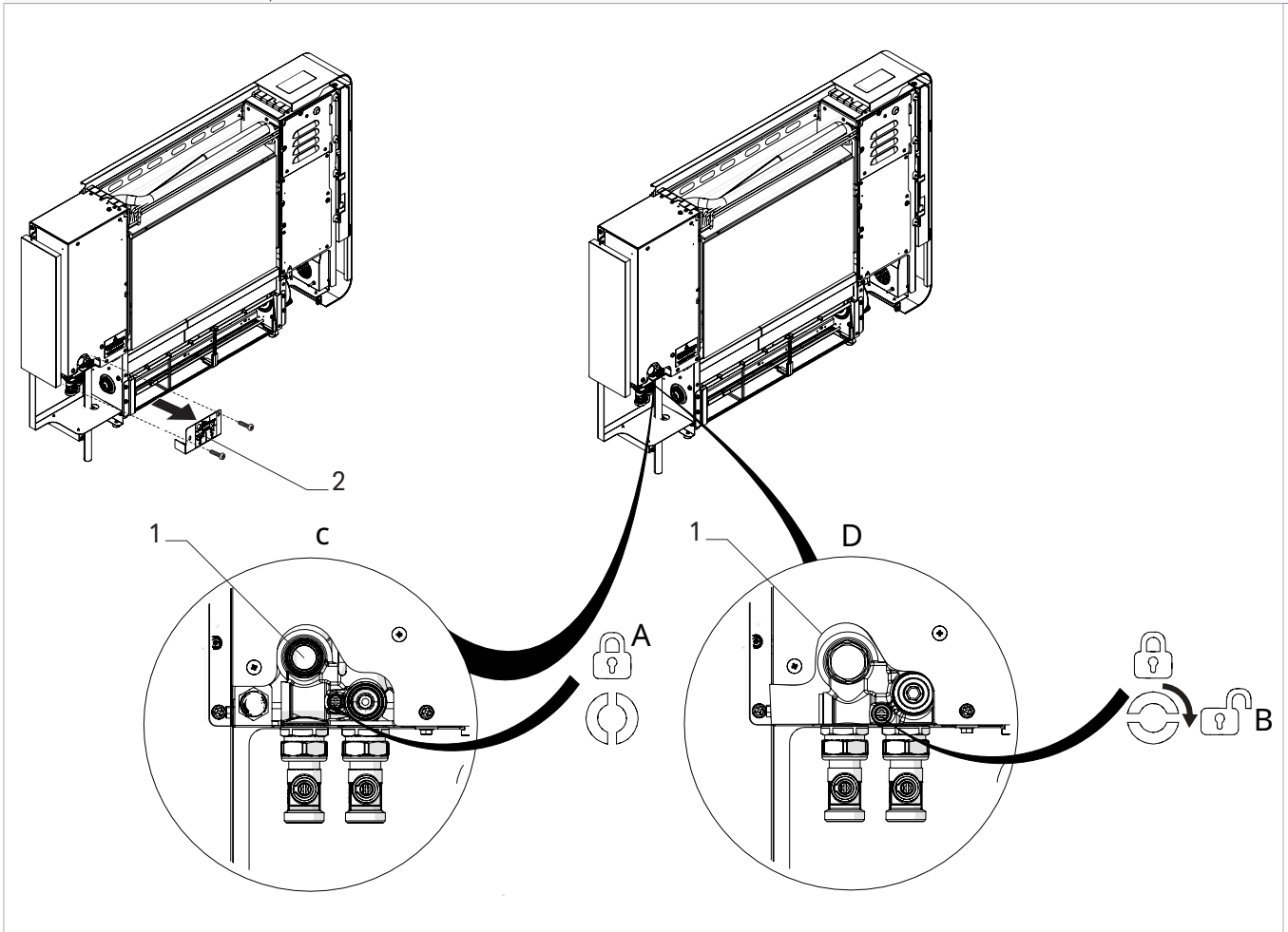

⚠ Check the valve code carefully to identify the 2-way only version or the 2/3-way version.

6.12.6 Filtration system

⚠ A filtering system must be installed on the loop in an area accessible for maintenance to safeguard the appliance from impurities in the water.

⚠ The recommended filtration system is through a dirt separator. Alternatively, a mesh filter can be used.

6.13 Filling the plant

The plant must be filled once the hydraulic connections have been completed.

6.13.1 Preliminary warnings

- ⚠ A filling system external to the unit must be provided.
- ⚠ All operations must be carried out with the machine stopped and disconnected from the power supply.
- ⚠ If an external auxiliary pump is used, it must be switched off.

⚠ The operating pressure of the plant must not exceed 1.5 bar with the pump off. To check for leaks in the plant during testing, it is advisable to raise the test pressure and then discharge it later to reach the correct working pressure. If the pressure exceeds 3 bar, the safety valve opens and discharges the excess water outside.

6.13.2 Water quality requirements

The quality of the water used must comply with the requirements set out in the following table; otherwise, a treatment system must be provided.

Plant water reference values		
pH		6,5 ÷ 7,8
Electrical conductivity	µS/cm	250 ÷ 800
Total hardness	°F	5 ÷ 15
Total Iron	ppm	0,2
Manganese	ppm	< 0,05
Chlorides	ppm	< 250
Sulphur ions		none
Ammonia ions		none

- ⚠ Well or groundwater not coming from an aqueduct should always be carefully analysed and, if necessary, conditioned with appropriate treatment systems.
- ⚠ A water softening plant must be used if the initial water hardness exceeds the value indicated in the table.
- ⚠ Excessive water softening (total hardness < 1.5 mmol/l) could generate corrosive phenomena in contact with metallic elements (piping or parts of the heat source). Also keep the conductivity value within 600 µS/cm.
- ⚠ Check the chloride concentration at the outlet after resin regeneration.
- ⊖ Introducing acids into the washing circuit is forbidden.
- ⊖ Constantly or frequently topping up the plant is forbidden because this can damage the heat exchanger of the appliance.

6.13.3 Filling

Before starting the filling operation:

- ▶ set the plant main switch in the OFF position.
- ▶ check that the plant drain cock is closed
- ▶ open all the air purge valves of the system

- ▶ open all the system's shut-off devices
- Open the vent valves of the appliance:**
- ▶ remove the access panel
 - ▶ open the vent valves of all terminals

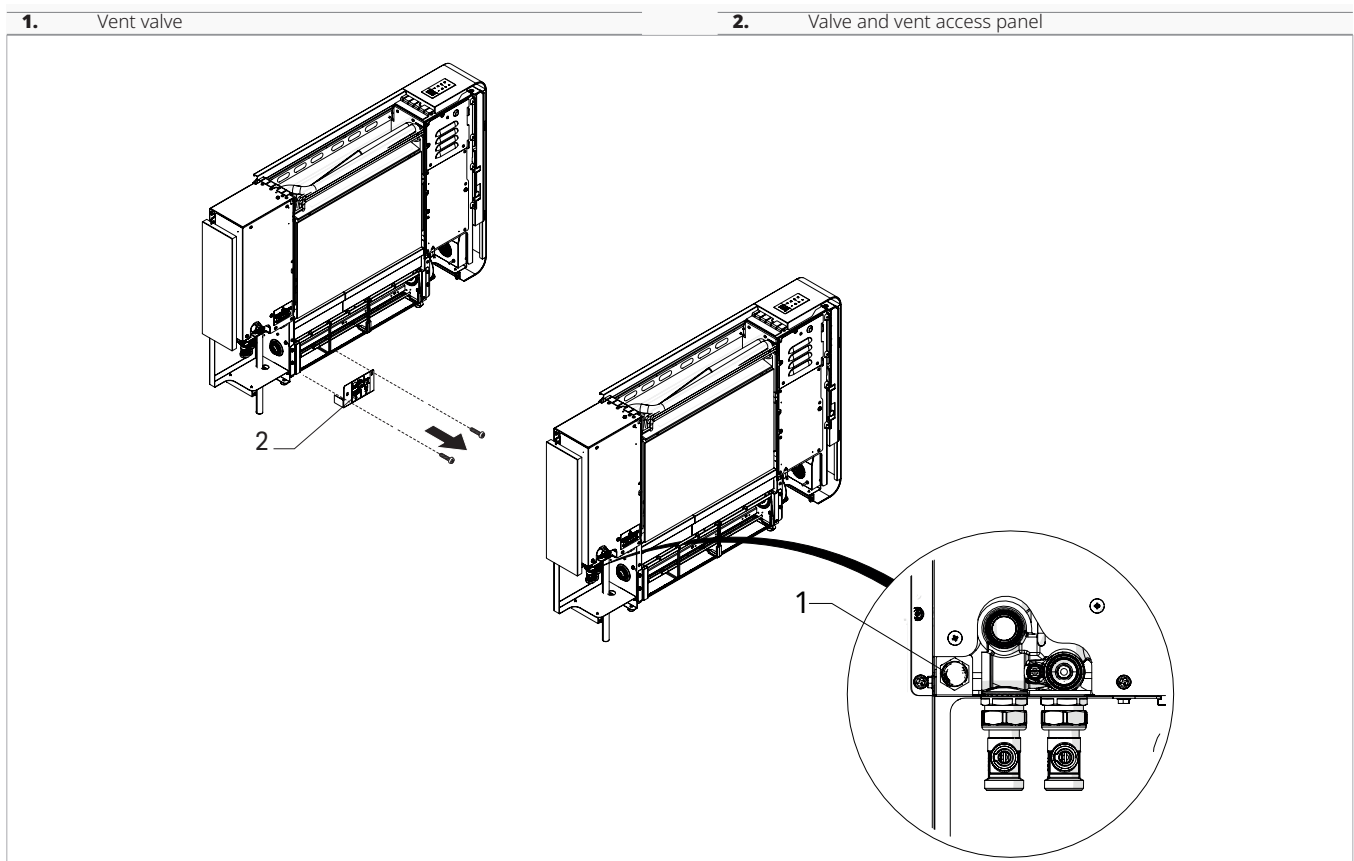

To fill the system:

- ▶ start filling by slowly opening the plant water filling cock on the outside of the appliance

When water starts coming out of the terminal vent valves:

- ▶ close the vent valves
- ▶ continue filling up to the pressure value required by the plant
- ▶ check that the expected nominal pressure has been reached
- ▶ isolate the water supply

- ▶ check the tightness of the gaskets

- ⚠ It is recommended to repeat this operation after the device has been running for a few hours.
- ⚠ Regularly check the system's pressure.
- ⚠ Keeping the system bleed open during operation may cause loss of performance and increase energy consumption.

6.14 Electric connections

6.14.1 Preliminary warnings

- ⚠ All operations of an electrical nature must be carried out by qualified personnel having the necessary training, who understands the legal requirements, and is informed about the risks related to such operations.
- ⚠ All connections must be made following the regulations in force in the country of installation.
- ⚠ Before carrying out any work, make sure that the power supply is switched off.
- ⚠ The unit must only be powered after all plumbing and electrical work has been completed.
- ⚠ References:
 - refer to the wiring diagrams in this manual for electrical connections
- ⚠ Make sure that:
 - the characteristics of the electric network are adapted to the absorption of the apparatus, considering also any other devices in parallel operation
 - the power supply voltage and system frequency match to the values indicated on the device's plate data
 - the cables must be appropriate for the type of installation in accordance with the applicable IEC standards
 - the power supply is provided with protection against overload and/or short-circuit
 - the disconnection device is located in an easily accessible place in order to be able to intervene in the event of an emergency
- ⚠ It is required:
 - provide a suitable earthing connection
 - provide an all-pole switch with a contact opening distance of 3 mm or more that allows complete disconnection under overvoltage category III conditions
 - install a residual-current device. Failure to install this device may result in electric shock
- ⚠ Use a dedicated power supply circuit. Never use a power supply to which another appliance is also connected because of the risk of overheating, electric shock or fire.
- ⚠ For the electrical connection, use a cable that is long enough to cover the entire distance without any connection. Do not use extension cables. Do not apply other loads on the power supply.
- ⚠ After connecting the interconnection and power cables, make sure that the cables are routed so that they do not apply excessive forces on the covers or electrical panels. Incomplete connection of the covers may result in overheating of the terminals, electric shock or fire.
- ⚠ Any replacement of the power cable must be carried out by authorised personnel and in accordance with the applicable national law.
- ⚠ The Manufacturer is not liable for any damage caused by the lack of earthing or failure to comply with the specifications in the respective diagrams.

⚠ The device is equipped with suppression filter as laid down by the applicable laws and standards. Use selective circuit breakers to compensate for the micro-dispersion on the earthing of this device.

⊖ It is forbidden the use of gas and water pipes for earthing the appliance.

Preliminary warnings for R290

- ⚠ R290 refrigerant gas is flammable and odourless.
- ⚠ Do not place flammable objects (spray cans) within 1 metre of the air outlet.
- ⚠ All precautions concerning the treatment of the refrigerant must be observed following the regulations in force.
- ⚠ Avoid proximity to sources of ignition in continuous operation (open flames, gas appliances, electric stoves, lighted cigarettes, etc.).
- ⊖ Smoking in the vicinity of the appliance is prohibited.
- ⊖ Using a mobile phone near the appliance is prohibited.
- ⚠ Perform the following checks:
 - carry out safety checks to ensure that the risk of combustion is minimised
 - avoid working in confined spaces
 - delimit the area around the workspace
 - ensure safe working conditions around the area by controlling flammable material

6.14.2 Power line dimensioning

For the size of the power supply cable and safety devices, use the following table.

Models	u.m.	10	20	30
Power Supply	V/ph/Hz	230/1/50	230/1/50	230/1/50
Maximum absorbed power	kW	0,40	0,89	1,15
Maximum absorbed current	A	1,74	3,87	5,01

6.14.3 Access to the terminal block

- 1. Fixing screws
- 2. Access panel

- 3. Terminal block for wiring
- 4. Cable gland

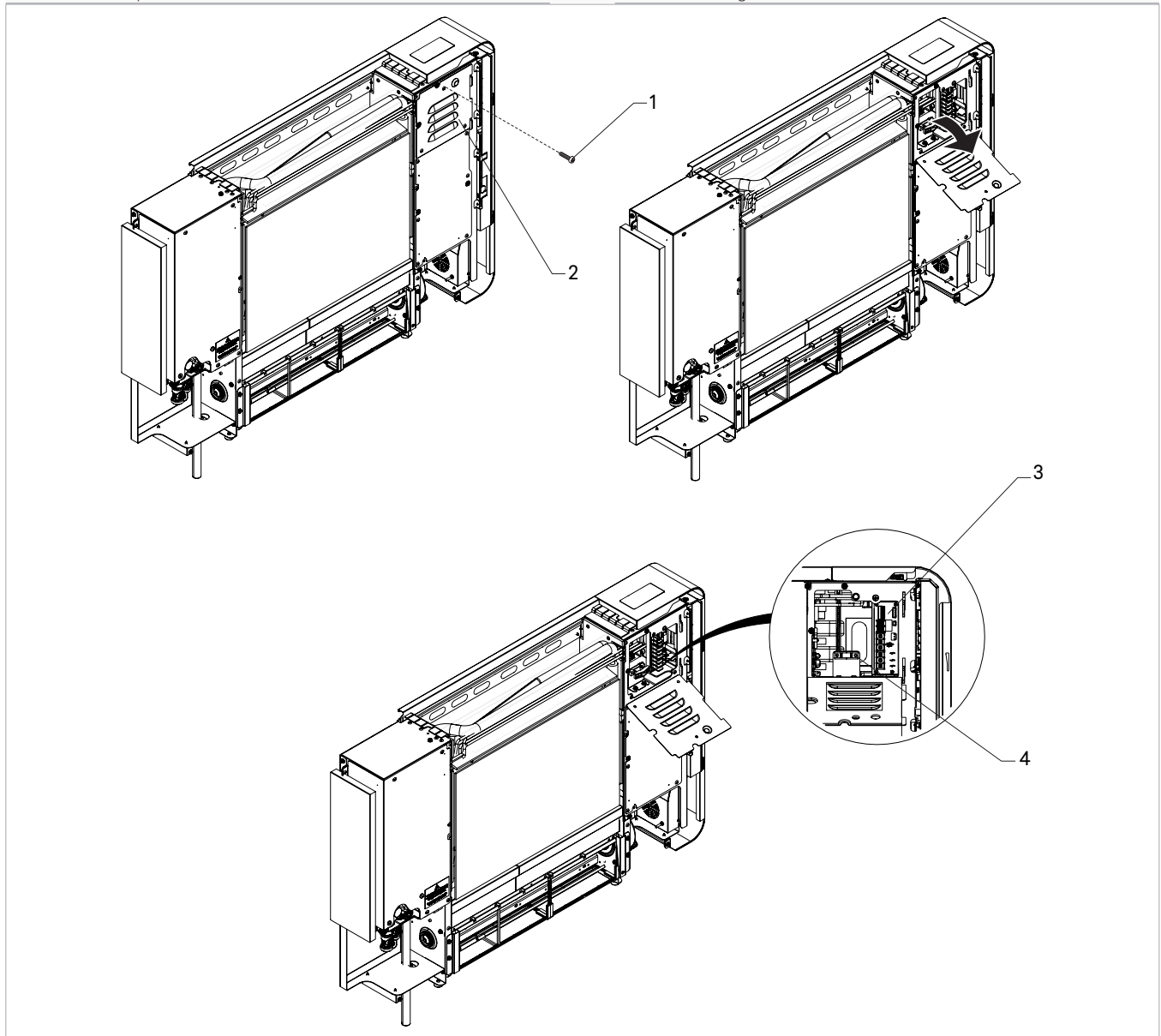

⚠ Before carrying out any works, please ensure the power supply is disconnected.

⚠ Access to the electrical panel is only permitted to qualified personnel.

To access:

- ▶ remove the front panel, if fitted

To access the connections:

- ▶ undo the electric panel fixing screw
- ▶ open the access panel

⚠ Refer to the information in the wiring diagram of the unit you are installing.

- ⚠ The electrical connection can be made by means of a cable laid in a wall-mounted conduit (see location shown on the template).
- ⚠ It is necessary to check that the power supply is provided with appropriate protection against electric shorts and/or overloads

6.14.4 Power supply connection

230~50	Unit power supply
AUX	Auxiliary 230V 5 A (activated by flow request)
C1	Generator call contact
CP	Presence contact (normally closed)
AB	Modbus connection / wall-mounted control
⊕	Earth connection

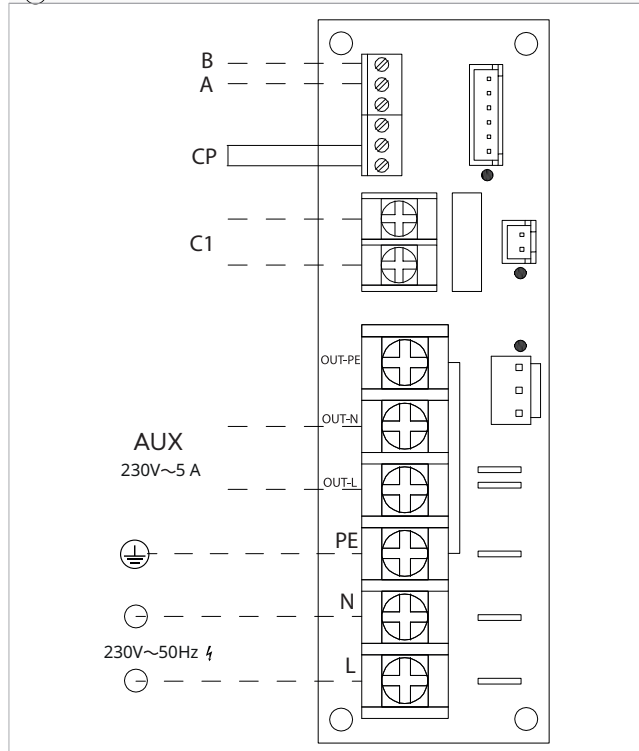

To make the connections:

- ▶ connect phase and neutral (L-N) to the connection terminal block
- ▶ connect the earth cable (⊕) to the connection terminal block
- ▶ fix the cable with the cable clamp

6.14.5 Auxiliary connections

Presence contact CP

When the CP contact opens (very low voltage, connected to a volt-free contact) the appliance is put in stand-by and CP appears on the display.

Through this contact it is possible to connect an external device that inhibits operation of the unit such as: window opening contact, remote on/off, infrared presence sensor, activation badge etc.

- ⚠ We recommend using a double insulated cable.

Generator call contact C1

Generator request contact. Activated when the appliance is calling (dry contact max. 1 A).

AB Modbus connection / wall-mounted control

Modbus connection for control with external supervisor.

6.15 Assembly of aesthetic panels and grilles

1. Fixing screws
2. Front panel

3. Upper grille

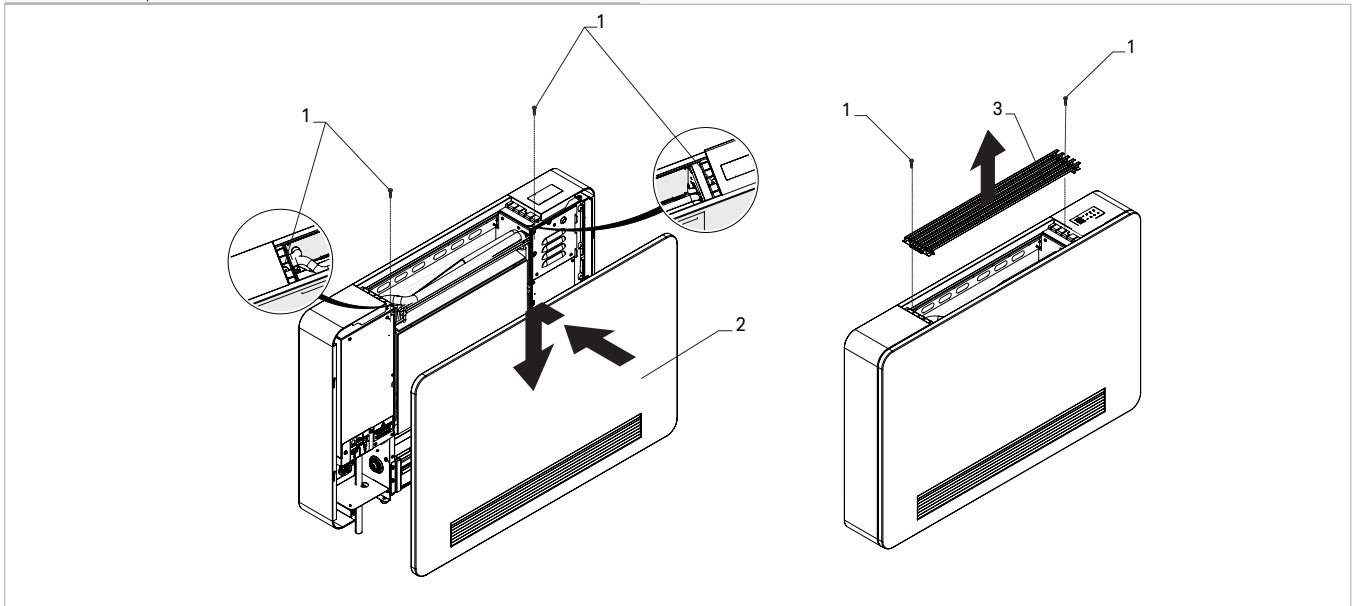

To assemble:

- ▶ position the front panel
- ▶ insert the fixing screws
- ▶ fasten the front panel fixing screws
- ▶ replace the upper grille
- ▶ insert the fixing screws
- ▶ fasten the upper grille fixing screws

7. TOUCHPAD - INTERFACE

7.1 Interface

7.1.1 Description

The touchpad control requires no connections and can be used to:

- show the operating status

- show any alarms
- select the various functions

⚠ For touchpad coding PCZ-EWA844, the Aquarea Home App is available.

7.1.2 Touchpad

Keys and functions related.

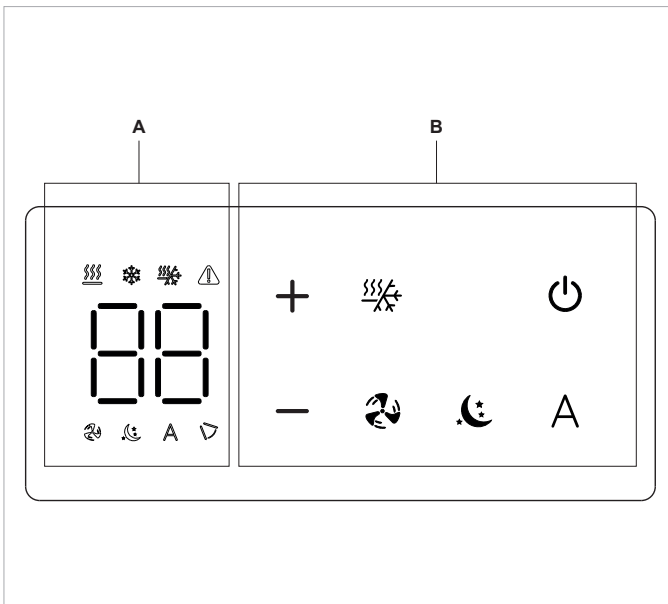







A	Display area
B	Keys area
	Setpoint
	Up key
	Down key
	This can be used to select the operating mode (Heating, Cooling or Auto-changeover)
	This can be used to select the power level (L1, L2, L3, L4)
	This can be used to switch the unit on or off
	Enables the Night function
	Enables the Automatic function
	Alarm signals

8. TOUCHPAD - MENU STRUCTURE

8.1 Touchpad

8.1.1 Structure overview

.....	Basic menu	# Access: hold down  for about 10 seconds
		# Contains: all the parameters that the user can modify according to the needs of the plant
		# Exit: press A twice
▶	Advanced menu	# Access: from the Basic menu simultaneously press   for about 5 seconds
		# Contains: the parameters that only the installer or qualified personnel can modify
		# Exit: press A , to go back to the Basic menu
.....	View menu	# Access: press simultaneously  A for about 10 seconds
		# Contains: information (in display only) on the current operation of the unit
		# Exit: press A twice
▶	Start menu	# Access: on the View menu, simultaneously press   for about 10 seconds
		# Contains: the parameters that only the installer or qualified personnel can modify
		# Exit: press A , to go back to the View menu

8.1.2 Structure details

.....	Basic menu	
▶	Ub	# Set: buzzer volume
		# Minimum: 00
		# Maximum: 03
▶	uP	# Set: Wi-Fi pairing
		# no: not activated
		# St: starting the pairing procedure
		# Setting: no
▶	ur	# Set: Wi-Fi reset
		# no: Not activated (default)
		# cr: Wi-Fi credentials reset
		# Sf: Not used
		# Hd: Not used
▶	oH	# Set: temperature offset in Heating mode
		# Minimum: -9 °C
		# Maximum: 9 °C
		# Setting: 0 °C
▶	oC	# Set: temperature offset in Cooling mode
		# Minimum: -9 °C
		# Maximum: 9 °C
		# Setting: 0 °C

- ▶ CF
 - # **Select:** temperature unit
 - # **°C:** degrees Celsius
 - # **°F:** degrees Fahrenheit

Advanced menu

- ▶ Fc (only with modulating valve)
 - # **Enable:** modulating valve flow configuration
 - # **Setting:** FL
- ▶ NO: no flow control, use as on/off valve (not used)
- ▶ FL: constant flow control
 - ▶ F1
 - # **Set:** water flow rate
 - # **Minimum:** 1
 - # **Maximum:** 20
 - # **Setting:**
 - # **Size 10:** 4
 - # **Size 20:** 8
 - # **Size 30:** 12
- ▶ dt: constant ΔT control
 - ▶ F1
 - # **Set:** heating ΔT
 - # **Minimum:** 1
 - # **Maximum:** 10
 - # **Setting:** 3
 - ▶ F2
 - # **Set:** cooling ΔT
 - # **Minimum:** 1
 - # **Maximum:** 10
 - # **Setting:** 3
- ▶ ot: constant output temperature control
 - ▶ F1
 - # **Set:** heating output temperature
 - # **Minimum:** 7
 - # **Maximum:** 40
 - # **Setting:** 9
 - ▶ F2
 - # **Set:** cooling output temperature
 - # **Minimum:** 7
 - # **Maximum:** 40
 - # **Setting:** 35
- ▶ HC
 - # **Select:** Heating only or Cooling only configuration
 - # **HC:** Heating and Cooling mode
 - # **HO:** Heating only mode
 - # **CO:** Cooling only mode
 - # **Setting:** HC
- ▶ ho
 - # **Enable:** Hotel mode
 - # **YS:** enabled
 - # **NO:** disabled
 - # **Setting:** NO
- ▶ in
 - # **State:** not used

▶ Ad	# Setting: Modbus address # Minimum: 01 # Maximum: 99 # Setting: 01
▶ rF	# Enable: remote function # YS: enabled # NO: disabled # Setting: NO
▶ co	# Enable: connectivity expansion module # YS: enabled # NO: disabled # Setting: YS
▶ iP	# Enable: injection pump kit activation # YS: enabled # NO: disabled # Setting: # NO: (default) # YS: for units with factory-fit injection pump kit

..... View menu

▶ UE	# View: firmware version
▶ FL	# View: water flow rate (L/min)
▶ in	# View: water loop inlet temperature (°C)
▶ ou	# Views: water outlet temperature (°C)
▶ Fi	# View: fan rotation speed (x100 rpm)
▶ CO	# View: compressor rotation speed (Hz)
▶ LE	# View: the level of condensate in the tray # Minimum: 1 # Maximum: 100 # hi: condensate level higher than maximum allowed # lo: condensate level below the minimum allowed

..... Start menu

▶ FF	# Force: modulating valve operation (for start-up operations only) # cL: forces full closing # oP: forces full opening # rA: temporarily activates self-regulation at nominal water flow rate # of: no forcing, use standard settings # Setting: of
▶ FL (repeats View menu item)	# View: water flow rate (L/min)
▶ in (repeats View menu item)	# View: water loop inlet temperature (°C)
▶ ou (repeats View menu item)	# Views: water outlet temperature (°C)

-
- ▶ iC (with injection pump kit only)
 - # **Run:** injection pump kit start-up procedure
 - # **of:** forces pump shutdown
 - # **St:** forces the pump priming procedure
 - # **on:** forces pump start-up
 - # **no:** no forcing, use standard settings
 - # **Setting:** of



 - ▶ LE (with injection pump kit only)
 - # **View:** the level of condensate in the tray
 - # **Minimum:** 0
 - # **Maximum:** 13
 - # **hi:** condensate level higher than maximum allowed
 - # **lo:** condensate level below the minimum allowed

9. TOUCHPAD - SETTINGS

⚠ In case of pairing of the touchpad with wall control, the connectivity expansion module must be deactivated. See paragraph "Connectivity expansion module" p. 48.

9.1 Basic menu

To access the basic menu



- ▶ press  for 10 seconds
Appears .

⚠ The control panel stores the last menu item used. The last position used appears at the next access.

To move within the menu or change values

- ▶ use 



To select a menu item and to confirm the changes made

- ▶ press 
The menu item is selected and the settings are accessed.
Changes are confirmed when the symbol  appears.

To exit menu items without saving

- ▶ press 
You exit the selected menu item.

To exit the basic menu

- ▶ press once 
Appears --.
- ▶ press  again
You exit the basic menu.

⚠ After a period of 30 seconds from the last action, the display exits the menu.

9.1.1 Menu items

Ub: Buzzer volume

uP: Provisioning Wi-Fi / BT

ur: Wi-Fi reset

oH: Temperature offset in Heating

oC: Temperature offset in Cooling

CF: Scale

9.1.2 Buzzer volume

To change the volume

- ▶ select 
the volume setting range is from 0 (min) to 3 (max).

⚠ The volume changes after change is confirmed.

9.1.3 Pairing

To make the pairing

- ▶ select 
- ▶ select St to enable pairing
ru appears when the pairing procedure is in progress.
YS appears when the pairing procedure has been completed.
By default the device is set to NO.

⚠ The device remains visible on Aquarea Home App for the first 15 minutes after the device is switched on.

⚠ The function is only available for touchpad control with Wi-Fi connection.

9.1.4 Wi-Fi reset

To reset the Wi-Fi

- ▶ select 
- ▶ select NO to disable Wi-Fi
- ▶ select cr to reset the credentials
By default the device is set to NO.

⚠ The function is only available for touchpad control with Wi-Fi connection.

9.1.5 Temperature offset in Heating

To set the temperature offset in Heating

- ▶ select 
The temperature offset setting range in Heating is from -9 °C (minimum) to 9 °C (maximum).

9.1.6 Temperature offset in Cooling

To set the temperature offset in Cooling

- ▶ select 
The temperature offset setting range in Cooling is from -9 °C (minimum) to 9 °C (maximum).

9.1.7 Scale

To change the temperature unit of measure



- ▶ select 
- ▶ select °C or °F
By default the temperature unit of measure is °C.

9.2 Advanced Menu

Through the control panel, it is possible to access the advanced menu.

⚠ To access the advanced menu, it is first necessary to access the basic menu. See section "Basic menu" p. 46.

To access the advanced menu



- ▶ from the basic menu press  at the same time for about 5 seconds
Appears 
The advanced menu is accessed.

⚠ The control panel stores the last menu item used. The last position used appears at the next access.

To move within the menu or change values

- ▶ use 



To select a menu item and to confirm the changes made

- ▶ press 
The menu item is selected and the settings are accessed.
Changes are confirmed when the symbol  appears.

To exit menu items without saving

- ▶ press 
You exit the selected menu item.

To exit the settings menu

- ▶ press 
Appears 
You return to the basic menu.

⚠ After a period of 30 seconds from the last action, the display exits the menu.

9.2.1 Menu items

FC: Modulating valve flow configuration

HC: Heating only or Cooling only configuration

ho: Hotel Mode

in: Not used

Ad: Modbus address

rF: Remote function

co: Connectivity expansion module

iP: Injection pump kit activation

9.2.2 Modulating valve flow configuration

⚠ The FC setting is only valid in the presence of the modulating valve.

To set the modulating valve flow configuration

- ▶ select 
- ▶ select FL to set constant flow control
- ▶ select dt to set constant ΔT control
- ▶ select ot to set constant output temperature control
By default, the appliance is set to FL.

⚠ The item NO cannot be used.

9.2.3 Heating only or Cooling only configuration

⚠ It is possible to disable the Heating or Cooling function by setting the unit in Heating only or Cooling only mode.

To set the Heating only or Cooling only mode

- ▶ select 
- ▶ select Hc to set the Heating and Cooling mode
- ▶ select Ho to set the Heating only mode
- ▶ select Co to set the Cooling only mode
By default, the unit is set to Hc.

9.2.4 Hotel Mode

To set the Hotel mode



- ▶ select 
- ▶ select YS to turn on Hotel mode
- ▶ select NO to turn off the Hotel mode
By default the device is set to NO.

Activating the Hotel mode:

- the Dehumidification Only and Automatic functions are deactivated
- only the Ventilation Only, Heating and Cooling functions remain active
- the temperature setting range is reduced, in Cooling you can set from 22 °C to 28 °C, in Heating you can set from 16 °C to 24 °C

9.2.5 Modbus address

To set the Modbus address

- ▶ select 
- ▶ act on 
- ▶ press  to confirm
By default the ModBus address is set to 1.
the setting range is from 1 (min) to 99 (max).

9.2.6 Remote function

To set the Remote function

- ▶ select 
- ▶ select NO to disable the Remote function
- ▶ select YS to enable Remote function
By default the device is set to NO.

⚠ Set the remote mode to make the touchpad view only.

⚠ The item is automatically set to YS when a control is connected.

9.2.7 Connectivity expansion module

To enable or disable the connectivity expansion module

- ▶ select □□
- ▶ select YS to activate the connectivity expansion module
- ▶ select NO to disable the connectivity expansion module

By default the device is set to NO.

⚠ In case of pairing with wall-mounted control, the connectivity expansion module must be deactivated.

9.2.8 Injection pump kit activation



To activate the injection pump kit

- ▶ select □□
 - ▶ select YS to activate
 - ▶ select NO to deactivate
- By default it is set to NO.*

9.3 View menu



The View menu can be accessed via the control panel.

To access the View menu



- ▶ press   at the same time for about 10 seconds
- CA appears.*
The start menu opens.

⚠ The control panel stores the last menu item used. The last position used appears at the next access.

To move within the menu or change values

- ▶ use  

To select a menu item and to confirm the changes made

- ▶ press 
- The menu item is selected and the settings are accessed.*
Changes are confirmed when the symbol  appears.

To exit menu items without saving

- ▶ press 
- You exit the selected menu item.*

To exit the View menu

- ▶ press 
- Compare UE.*

⚠ The control panel stores the last menu item used. The last position used appears at the next access.
Exits the View menu.

9.3.1 Menu items

UE: Firmware version

FL: Water flow rate (L/min)

in: Water inlet temperature (°C)

ou: Water outlet temperature (°C)

Fi: Fan rotation speed (x100 rpm)

CO: Compressor rotation speed



Le: Condensate level in the tray

9.4 Start menu

The Start menu can be accessed via the control panel.

⚠ **To access the Start menu, it is first necessary to access the View menu. See paragraph "View menu" p. 48.**



To access the Start menu

- ▶ from the View menu, press simultaneously   for about 10 seconds
- FF appears.*



⚠ The control panel stores the last menu item used. The last position used appears at the next access.

The start menu opens.

To move within the menu or change values

- ▶ use  

To select a menu item and to confirm the changes made

- ▶ press 
- The menu item is selected and the settings are accessed.*
Changes are confirmed when the symbol  appears.

To exit menu items without saving

- ▶ press 
- You exit the selected menu item.*

To exit the Start menu

- ▶ press 
- FF appears.*

⚠ The control panel stores the last menu item used. The last position used appears at the next access.
Exits the Start menu.

9.4.1 Menu items

FF: Forces modulating valve operation

Options:

of: No forcing, use standard settings

cL: Forces full closing

oP: Forces full opening

rA: Activates self-regulation at nominal water flow rate

FL: Water flow rate (L/min)

in: Water inlet temperature (°C)

ou: Water outlet temperature (°C)



IC: Injection pump kit start-up procedure



LE: Condensate level in the tray

 To be used for start-up operations only.

9.5 Visualisation of alarms on display

 In the event of an alarm, the device still maintains active functions.

 Alarms are indicated on the touchpad by the fixed  symbol and the alarm code.

Code	Alarm description
Er01	Ambient temperature sensor disconnected or faulty
Er02	Air exchanger temperature error
Er03	Source fluid temperature sensor error at plate heat exchanger outlet
Er04	Plate heat exchanger temperature sensor error
Er05	Faulty internal fan motor
Er06	Source fluid temperature error at plate heat exchanger inlet
Er07	Driver communication error
Er08	Compressor discharge sensor error
Er09	Communication error with remote thermostat
Er10	Condensate level in the bowl too high
CP	CP contact activation
Er12	Driver error
CE	Communication error between main circuit board and display
Er14	No water flow in the plate heat exchanger (loop)
Er16	No refrigerant / 4-way valve malfunction
Er17	Driver parameter error
Er18	Plate heat exchanger fluid flow error
Er21	Inverted plate heat exchanger fluid flow
Er22	Incorrect supply voltage
  *	Water inlet temperature > 55 °C or < 6 °C
* flashing	

10. WALL-MOUNTED CONTROL COD. PCZ-EEB749

10.1 Interface

10.1.1 Description

LED electronic control panels with touch interface for wall installation allow:

- room temperature control
- management of the main functions of the device
- temperature and humidity measurement
- fan speed regulation

They are fitted with:

- internal memory with data saving even in case of shut-down or power outage

⚠ After 20 seconds after the last action the panel brightness is reduced, only the room temperature is seen on the display.

⚠ The maximum brightness is restored to the pressure of any key.

⚠ Firmware version higher than 1.7 is needed.

⚠ **In case of pairing with units with connectivity expansion module (Wi-Fi), it must be deactivated on the Touchpad. See paragraph "Connectivity expansion module" p. 48.**

10.1.2 Display

Status and active alarms on display.

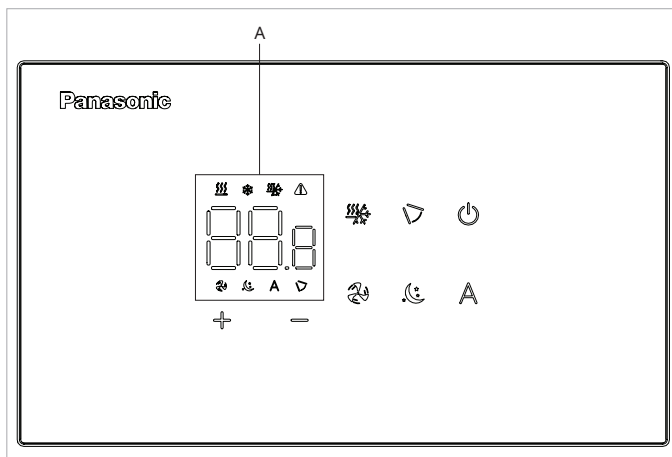

A	Display area
88.8	This indicates the setpoint (after 20 seconds it indicates the measured temperature)
⚠	Alarm signalling or function inhibited
▽	Function not available
🌀	Active ventilation function
🔥	Heating / Cooling (Automatic)
❄️	Cooling operating mode active
🔥	Heating operating mode active
⏸	Automatic function active
🌙	Night function active

10.1.3 Keys functions

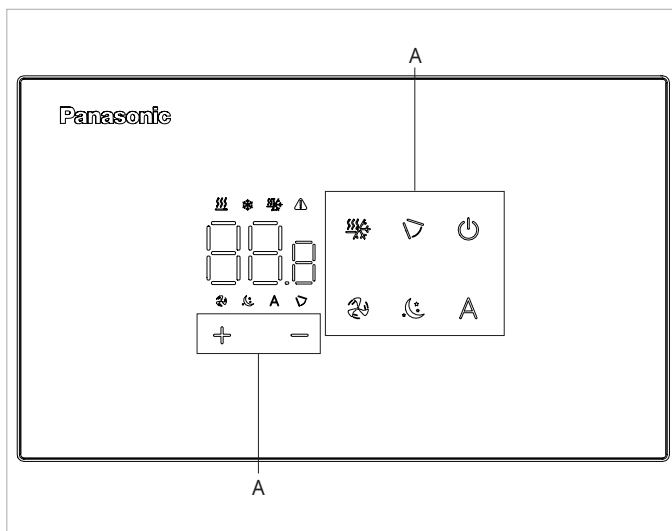

A	Keys area
+	Up key
-	Down key
🔥	This can be used to switch the unit on or off
▽	Function not available
🌀	This can be used to select the power level (L1, L2, L3, L4)
🔥/❄️	This can be used to select the operating mode (Cooling or Heating) or Autochangeover
⏸	Enables the Automatic function
🌙	Enables the Night function

10.2 Installation

10.2.1 Description

The wall-mounted remote control is an electronic LED thermostat with a touch interface, with the possibility of controlling multiple appliances equipped with the same electronic board. It is equipped with a temperature and humidity probe.

⚠ The control can manage a maximum of 16 units.

10.2.2 Mounting

⚠ The control panel must be mounted in an electrical back box.

⚠ A wall must be prepared to accommodate the electrical box before installing the wall control.

⚠ Ensure that:

- the wall supports the weight of the appliance
- the section of the wall does not contain piping or electrical lines
- the functionality of load-bearing elements is not compromised

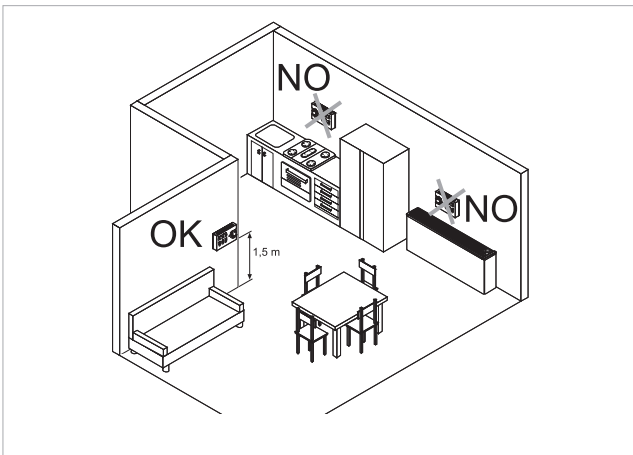

The wall-mounted remote control must be installed:

- on internal walls
- at a height of about 1,5 m from the floor

⚠ Should the control be located in an area utilised by persons with reduced physical capabilities, please refer to local regulations.

- away from doors or windows
- away from heat sources (heaters, convectors, stoves, direct sunlight)

⚠ The wall control is provided inside the package already assembled.

1. Back plate
2. Wall-mounted control panel

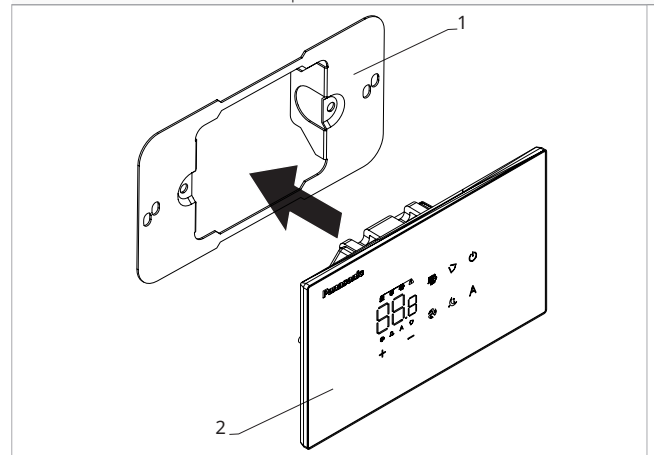

Before wall installation:

- ▶ separate the back plate from the control panel

1. Fixing screws
2. Back plate
3. Holes for fixing to electrical box
4. Electrical back box

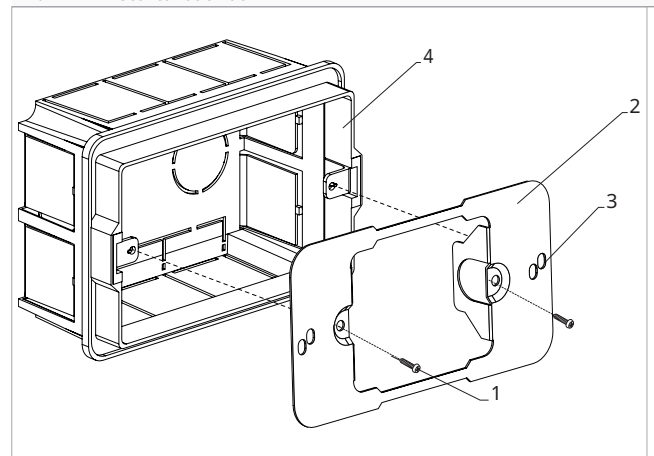

For wall mounting of the control panel:

- ▶ fix the back plate to the electrical back box with screws
- ▶ connect the electrical wiring

⚠ Before making the connections, please verify that the control terminal block is on the right-hand side.

1. Electrical back box
2. Back plate
3. Wall-mounted control panel

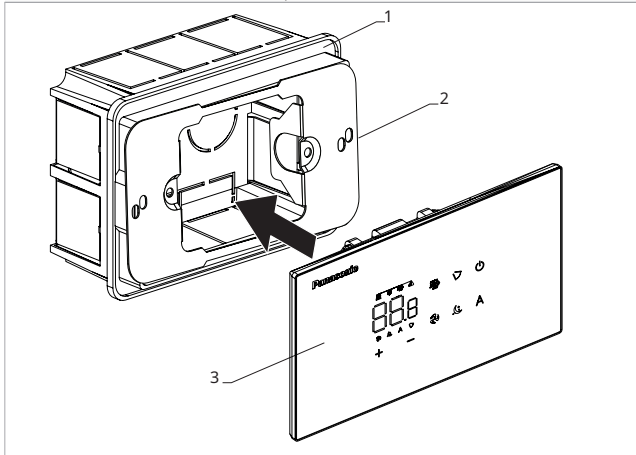

► Close the control panel

⚠ Pay attention not to crush the conductors when you close the control.

10.3 Single connection diagram

- 1.** Wall-mounted control panel
- 2.** Terminal block for device connection
- CP** Presence contact
- BA** Serial connection for wall-mounted remote control

- 12 V-DC 1A power supply
- Earth connection
- 230~50** Power supply connection 230 V / 50 Hz / 1 A
- RC** Wall-mounted control

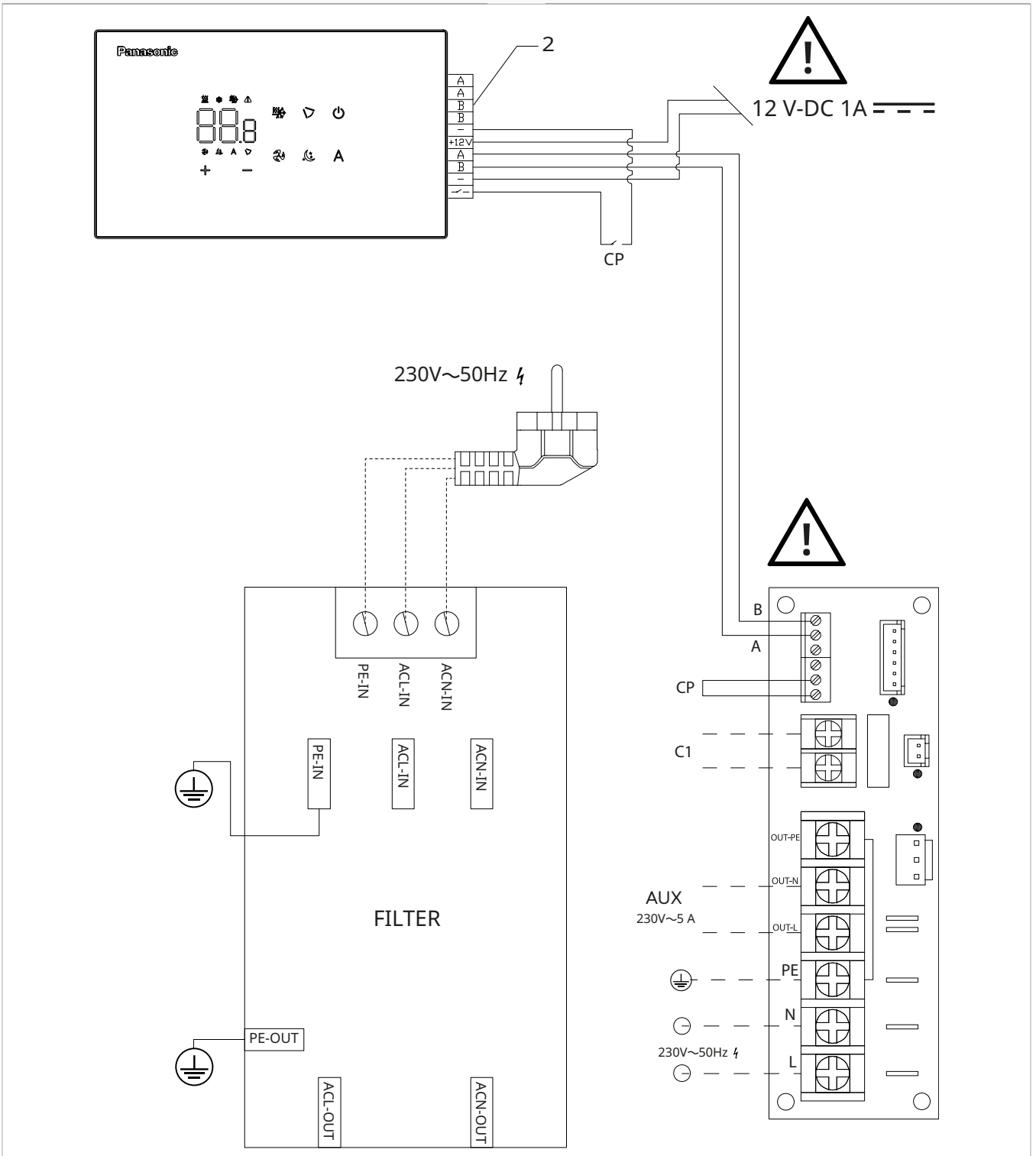

Reverse A and B for connecting the wall control panel with the board.

Power for the control is to be supplied through a 12 V-DC 1A power supply (not field supplied).

10.4 Multiple connection diagram

- 1.** Wall-mounted control panel
- 2.** Terminal block for device connection
- CP** Presence contact

- BA** Serial connection for wall-mounted remote control
- +** 12 V-DC 1A power supply
- RC** Wall-mounted control

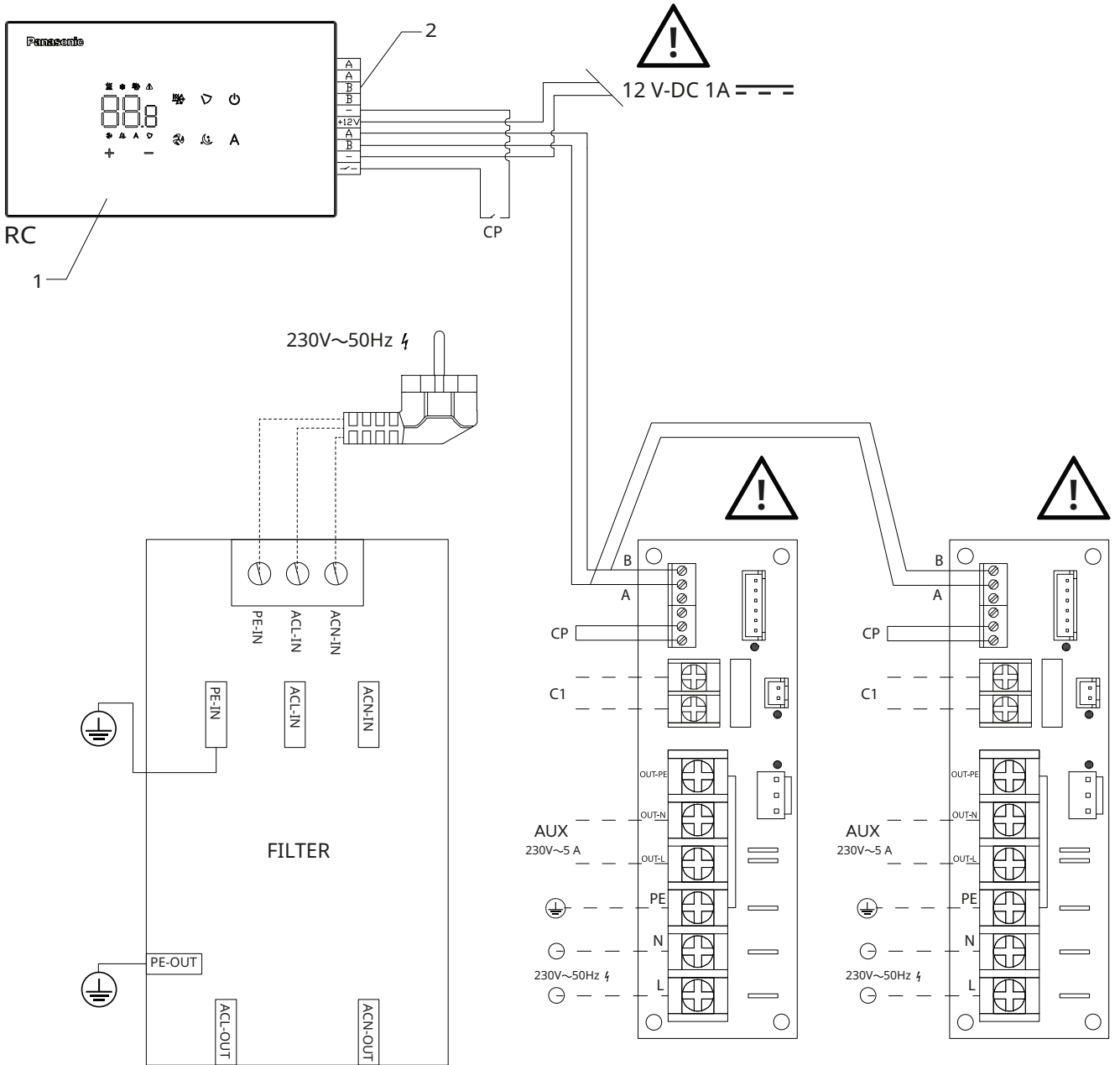

⚠ Reverse A and B for connecting the wall control panel with the boards.

⚠ Power for the control is to be supplied through a 12 V-DC 1A power supply (not field supplied).

10.5 Connections

10.5.1 Preliminary warnings

The terminals accept:

- rigid or flexible wires with a 0.2 to 1 mm² cross-section
- rigid or flexible wires with 0,5 mm² cross-section if two wires are connected to the same terminal block
- rigid or flexible wires with 0,75 mm² cross-section If the wires have wire end ferrules with a plastic collar

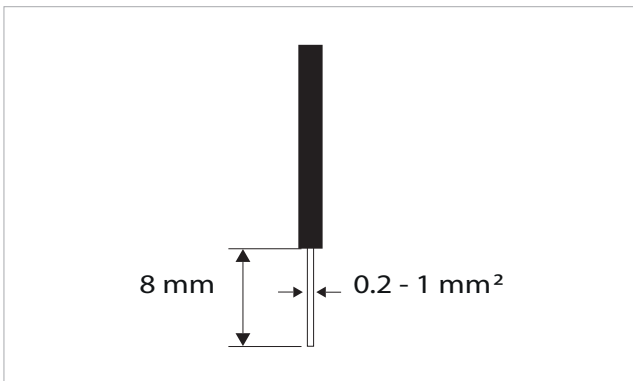

To connect the cables:

- ▶ strip 8 mm of the wire
- ▶ if the wire is rigid, you can insert it easily whereas
- ▶ if it is flexible, use appropriate crimp terminals
- ▶ push the wire in completely
- ▶ check the right fixing by pulling it gently

10.5.2 Control Panel

⚠ The control panel for wall control must be ordered separately.

Terminal block position:

1. Terminal block (Back view panel)

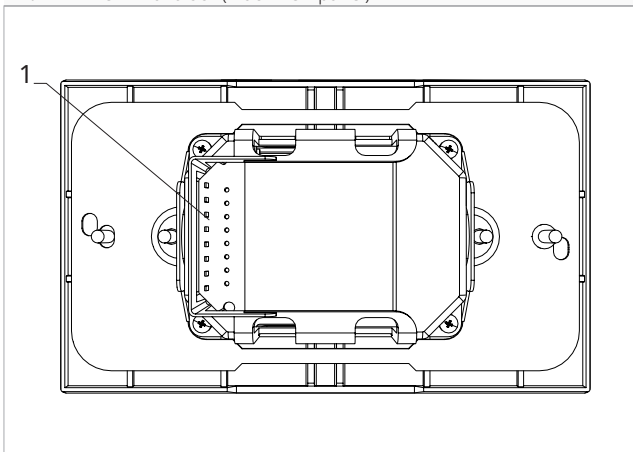

To make the connections:

- ▶ connect the + - power supply wires to a 12 V-DC 1A power supply
- ▶ connect the Modbus serial connection cables to terminals A and B

⚠ Reverse A and B for connecting the wall control panel with the board.

10.5.3 Presence contact CP

Through this device it is possible to connect an external control signal that inhibits the operation of the control signal, for example:

- opening window contact
- remote on/off
- infrared presence sensor
- activation badge
- remote change of season

Function

The contact is normally open (NO).

- ▶ when closing the CP contact, connected to a potential-free contact, the device switches to standby mode
CP appears on the display.
- ▶ At the touch of a button on the display the symbol ⚠ flashes.

⊖ It is forbidden to connect the CP input to that of another unit electronic board. Use separate contacts.

10.5.4 RS485 Serial Connection

The wall-mounted remote control can be connected through an RS485 serial line to one or more devices, up to a maximum of 16.

The devices must be equipped with an electronic board suitable for remote control.

For the connection:

- ▶ follow the indication on the connection diagram
- ▶ connect respecting the polarity indication A and B

⚠ Use a two core cable shielded cable suitable for the RS485 serial connection with a minimum section of 0,35 mm².

⚠ Keep the two core cable separate from power supply cable by a minimum of 50 mm.

⚠ Create a wire path in order to minimize the length of the lead wire.

⚠ Complete the line with the 120 Ω resistor.

⊖ It is forbidden make star connections.



⚠ In the case of a connection between several devices, it is mandatory to carry out the matching between control and device.

10.5.5 Extended display





To enable device connectivity and enable selection of fan power level, the display must be extended. See section "Extended display" p. 57.

10.6 Basic menu



To switch on the control

- ▶ press and hold  for 3 seconds
The display shows .
- ▶ release 
The display lights up.

To access the basic menu

- ▶ with the display switched on, press and hold  until  appears
- ▶ release the  key
The symbol  appears

To navigate in the menu

- ▶ use the icons  

To select a menu item and to confirm the changes made



- ▶ press the icon 
Confirming the change takes you to the next item.

To exit the menu

- ▶ wait 30 seconds for automatic shutdown

 After a period of 30 seconds from the last action, the display exits the menu.

To switch off the control

- ▶ press and hold  for 3 seconds
oF appear.
- ▶ release the  key
The display turns off.

10.6.1 Menu items

ot: AIR probe offset (air probe setting)

ur: Value read by the R.H. sensor

ut: Probe Offset PT4

uS: Humidity setpoint

uI: Humidity hysteresis

CF: Scale





ub: Buzzer volume

uu: Not used

uP: Not used

10.6.2 Set AIR probe offset





To set the air probe offset

- ▶ select 
- ▶ press  to change settings
- ▶ increase or decrease the value with the icons  
- ▶ press  to confirm
*By default it is set to -2,5°C.
The setting range is from a minimum of -12.0 °C to a maximum of 12.0 °C.*

10.6.3 Set probe offset RH





 Modify only after real deviations from an actual measurement has been established with professional equipment.

To set the RH probe offset

- ▶ select 
- ▶ press  to change settings
- ▶ increase or decrease the value with the icons  
- ▶ press  to confirm
By default it is set to -2,5.





10.6.4 Set the humidity setpoint

To set the humidity setpoint

- ▶ select 
- ▶ press  to change settings
- ▶ increase or decrease the value with the icons  
- ▶ press  to confirm
*By default it is set to 50.
The setting range is from 20.0% to 90.0%.*



10.6.5 Setting the humidity hysteresis

To set the humidity hysteresis

- ▶ select 
- ▶ press  to change settings
- ▶ increase or decrease the value with the icons  
- ▶ press  to confirm
*By default it is set to 5.
The setting range is from 1 (min) to 30 (max).*





10.6.6 Scale

To change the temperature unit of measure

- ▶ select 
- ▶ press  to change settings
- ▶ select °C or °F
- ▶ press  to confirm
By default the temperature unit of measure is ° C.

10.6.7 Adjusting the volume

To change the volume

- ▶ select 
- ▶ press  to change settings
- ▶ increase or decrease the value with the icons  
- ▶ press  to confirm
*By default it is set to 1.
the volume setting range is from 0 (min) to 3 (max).*





 The volume changes after confirming the modification.

10.7 Advanced Menu

Through the control panel, it is possible to access the advanced menu.

⚠ To access the advanced menu, it is first necessary to access the basic menu. See section "Basic menu" p. 56.

To access the advanced menu

- ▶ from the basic menu press **A**
Appears 
- ▶ press the  key once
Appears 
- ▶ press  to confirm and log in
The advanced menu is accessed.

To navigate in the menu

- ▶ use the icons  

To select a menu item and to confirm the changes made

- ▶ press  for 2 seconds
Confirming the change takes you to the next item.

To exit the menu

- ▶ wait 30 seconds after the last action

⚠ After a period of 30 seconds from the last action, the display exits the menu.

10.7.1 Menu items

Ad: Modbus address (only used when connecting with the Aquarea Home)

Pr: Not used

di: Options for digital input

rH: Not used

rC: Not used

UC: Not used

Ac: Not used

Ah: Not used

Ed: Extended display





Ab: Enabling brightness sensor





Fr: Not used

10.7.2 Set device address for communication

⚠ Used only in case of connection with the Aquarea Home.

To set the Modbus address



- ▶ select 
- ▶ press  to change settings
- ▶ press   simultaneously to change the value shown on the display
The value shown in the display flashes.

- ▶ press  to confirm
- ▶ increase or decrease the value with the icons  
- ▶ press  to confirm
*By default the Modbus address is set to 01.
The setting range is from 01 (min) to 99 (max).*

10.7.3 To select digital input

⚠ Used only in case of connection with the Aquarea Home.

To change the digital input

- ▶ select 
- ▶ press  to change settings
- ▶ select CP for presence contact (default)
- ▶ select CO to cooling open
- ▶ select CC to cooling close
- ▶ press  to confirm
By default digital input is set to CP.

⚠ For return to the default settings, set the digital input to "CP".

⚠ By selecting one of the other inputs (CO,CC) the seasonality is locked. It is not possible to modify it through the key  of the control.

10.7.4 Extended display

⚠ Allows device connectivity and enables the selection of the ventilation power level.

⚠ To use the ventilation speed selection, it is necessary to enable the display extension.





To enable the display extension

- ▶ select 
- ▶ select no to disable
- ▶ select Ys to enable
By default, the device is set to no.

10.7.5 Optical sensor

⚠ By default, the brightness sensor is set.

To disable the brightness sensor:

- ▶ select 
- ▶ press 
Appear Ys.
- ▶ press 
- ▶ select no
- ▶ press  to confirm
The brightness sensor is disabled.

⚠ The brightness sensor adapts to room lighting.

10.8 Alarm display on wall control panel

- ⚠ In the event of an alarm, the device still maintains active functions.
- ⚠ Alarm codes are shown on the on-board display. Refer to the "Visualisation of alarms on display" *p. 77* chapter for the complete list.

11. WALL-MOUNTED CONTROL PCZ-EFB749

11.1 Interface

11.1.1 Description

LED electronic control panels with touch interface for wall installation allow:

- room temperature control
- management of the main functions of the device
- temperature and humidity measurement
- fan speed regulation

They are fitted with:

- internal memory with data saving even in case of shut-down or power outage

⚠ After 20 seconds after the last action the panel brightness is reduced, only the room temperature is seen on the display.

⚠ The maximum brightness is restored to the pressure of any key.

⚠ Firmware version higher than 1.7 is needed.

⚠ **It is mandatory to disable the connectivity expansion module (Wi-Fi) from the Touchpad. See paragraph "Connectivity expansion module" p. 48.**

⚠ For wall control coding PCZ-EFB749, the Aquarea Home App is available.

11.1.2 Display

Status and active alarms on display.

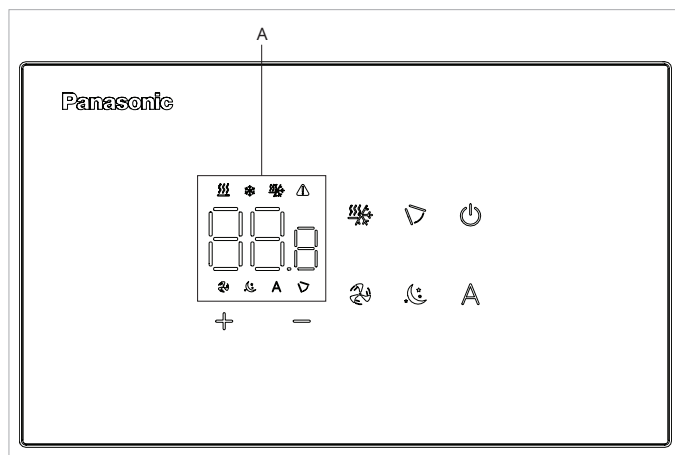

A	Display area
	This indicates the setpoint (after 20 seconds it indicates the measured temperature)
	Alarm signals
	Function not available
	Active ventilation function
	Heating / Cooling (Automatic)
	Cooling operating mode active
	Heating operating mode active
	Automatic function active
	Night function active

11.1.3 Keys functions

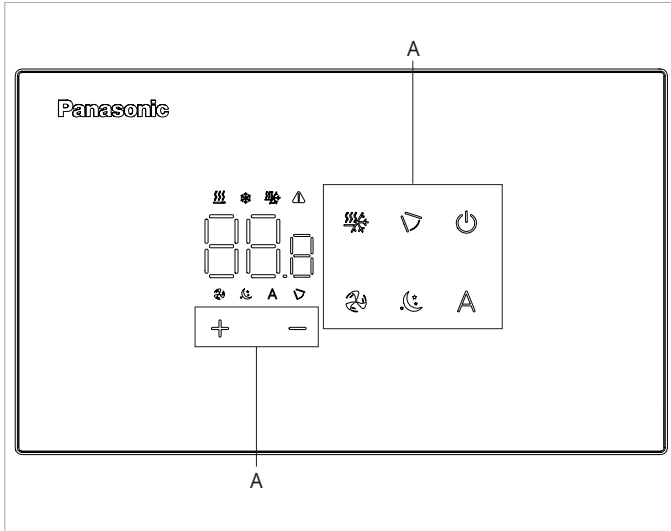

A	Keys area
	Up key
	Down key
	This can be used to switch the unit on or off
	Function not available
	This controls the ventilation speed (L1, L2, L3, L4)
	This can be used to select the operating mode (Cooling or Heating) or Autochangeover
	Enables the Automatic function
	Enables the Night function

11.2 Installation

11.2.1 Description

The wall-mounted remote control is an electronic LED thermostat with a touch interface, with the possibility of controlling multiple appliances equipped with the same electronic board. It is equipped with a temperature and humidity probe.

- The control can manage a maximum of 16 units.
- For wall control coding PCZ-EFB749, the Aquarea Home App is available.

11.2.2 Mounting

- The control panel must be mounted in an electrical back box.
- A wall must be prepared to accommodate the electrical box before installing the wall control.
- Ensure that:
 - the wall supports the weight of the appliance
 - the section of the wall does not contain piping or electrical lines
 - the functionality of load-bearing elements is not compromised

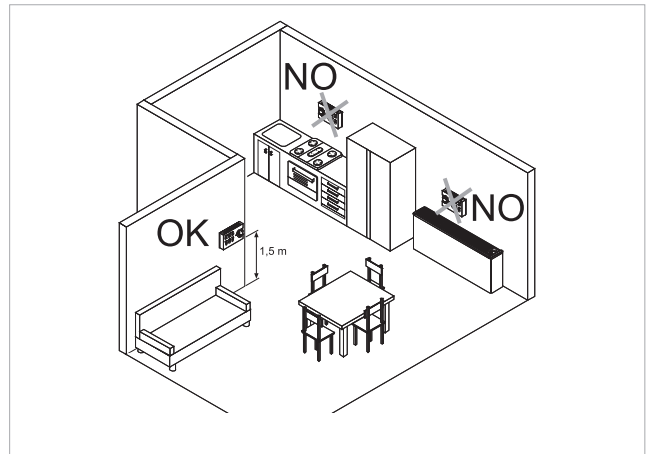

The wall-mounted remote control must be installed:

- on internal walls
- at a height of about 1,5 m from the floor
- Should the control be located in an area utilised by persons with reduced physical capabilities, please refer to local regulations.
 - away from doors or windows
 - away from heat sources (heaters, convectors, stoves, direct sunlight)
- The wall control is provided inside the package already assembled.

- | | |
|----|----------------------------|
| 1. | Back plate |
| 2. | Wall-mounted control panel |

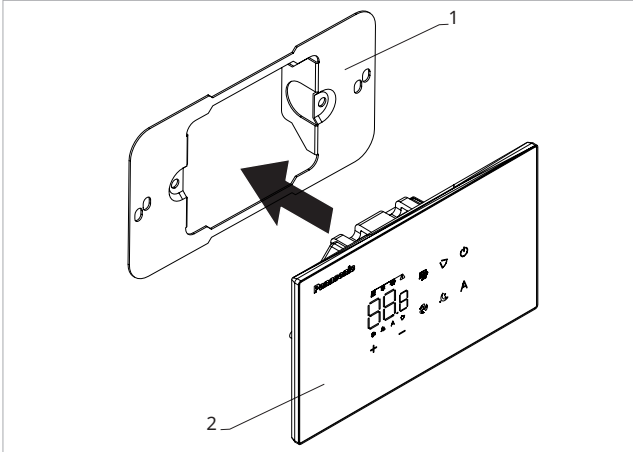

⚠ Pay attention not to crush the conductors when you close the control.

Before wall installation:

- ▶ separate the back plate from the control panel

- | | |
|----|------------------------------------|
| 1. | Fixing screws |
| 2. | Back plate |
| 3. | Holes for fixing to electrical box |
| 4. | Electrical back box |

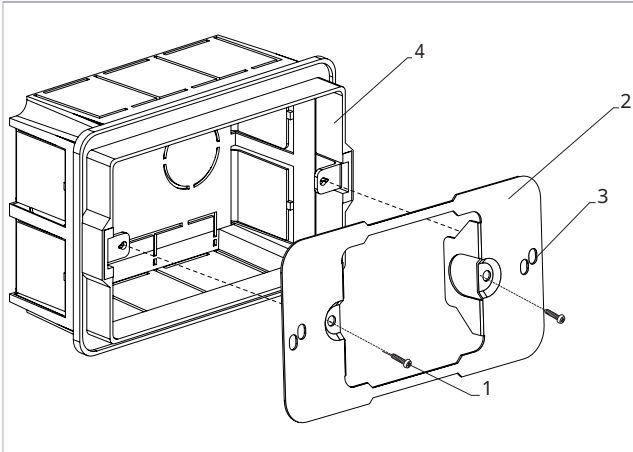

For wall mounting of the control panel:

- ▶ fix the back plate to the electrical back box with screws
- ▶ connect the electrical wiring

⚠ Before making the connections, please verify that the control terminal block is on the right-hand side.

- | | |
|----|----------------------------|
| 1. | Electrical back box |
| 2. | Back plate |
| 3. | Wall-mounted control panel |

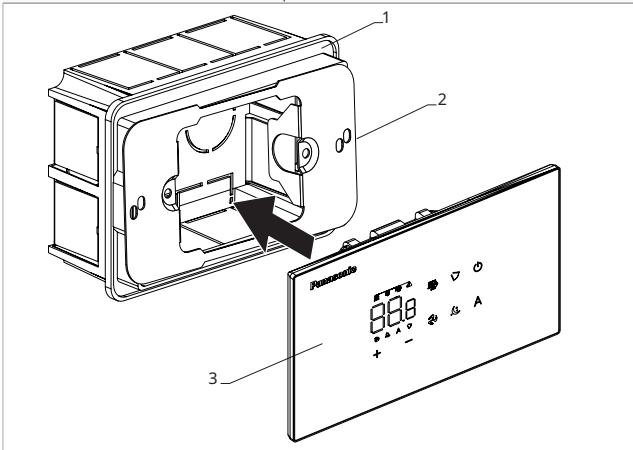

- ▶ Close the control panel

11.3 Single connection diagram

- 1. Wall-mounted control panel
- 2. Terminal block for device connection
- CP Presence contact
- BA Serial connection for wall-mounted remote control

- 12 V-DC 1A power supply
- Earth connection
- 230~50** Power supply connection 230 V / 50 Hz / 1 A
- RC** Wall-mounted control

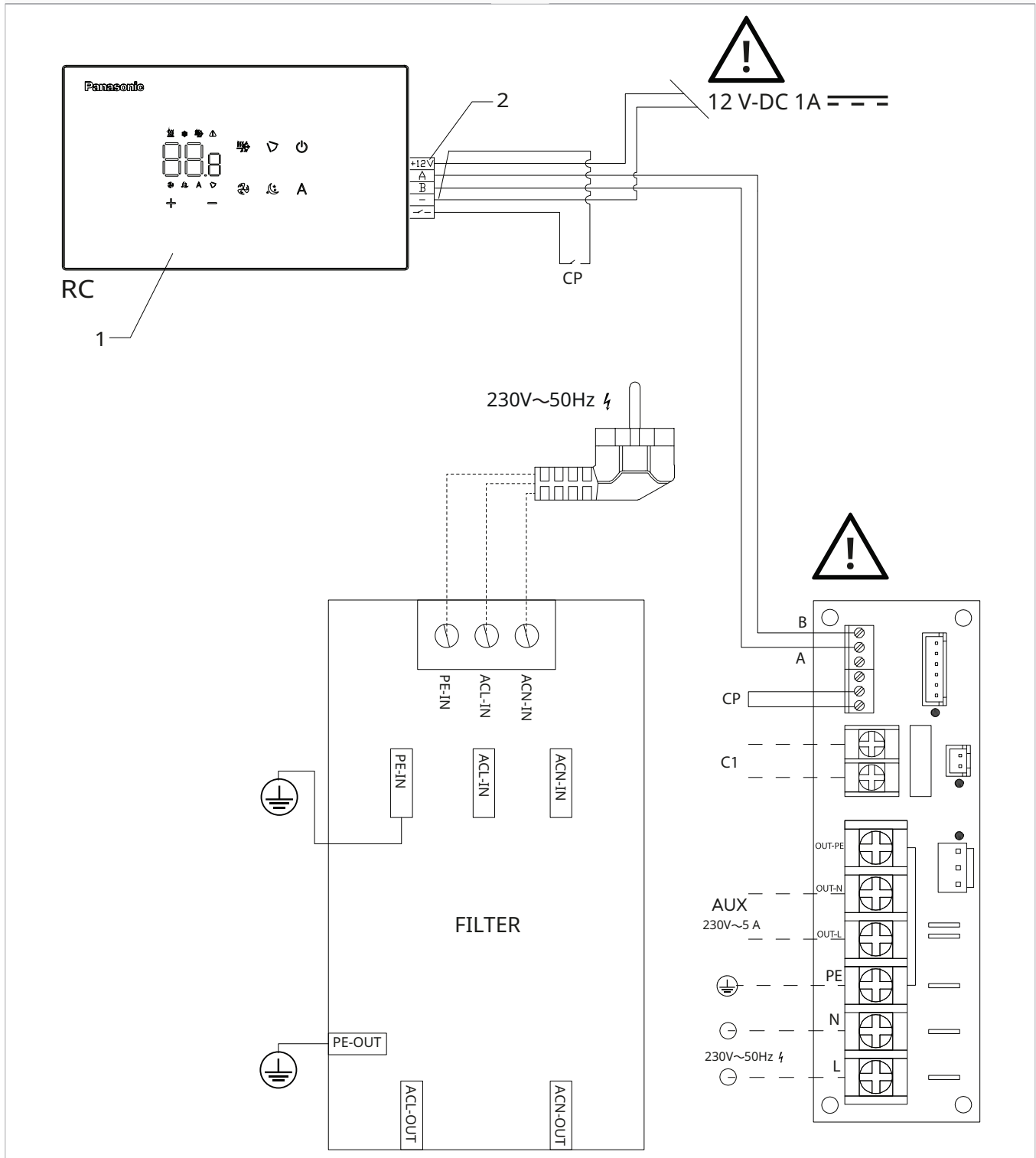

Reverse A and B for connecting the wall control panel with the board.

Power for the control is to be supplied through a 12 V-DC 1A power supply (not field supplied).

11.4 Multiple connection diagram

- 1.** Wall-mounted control panel
- 2.** Terminal block for device connection
- CP** Presence contact

- BA** Serial connection for wall-mounted remote control
- 12V-DC 1A** 12 V-DC 1A power supply
- RC** Wall-mounted control

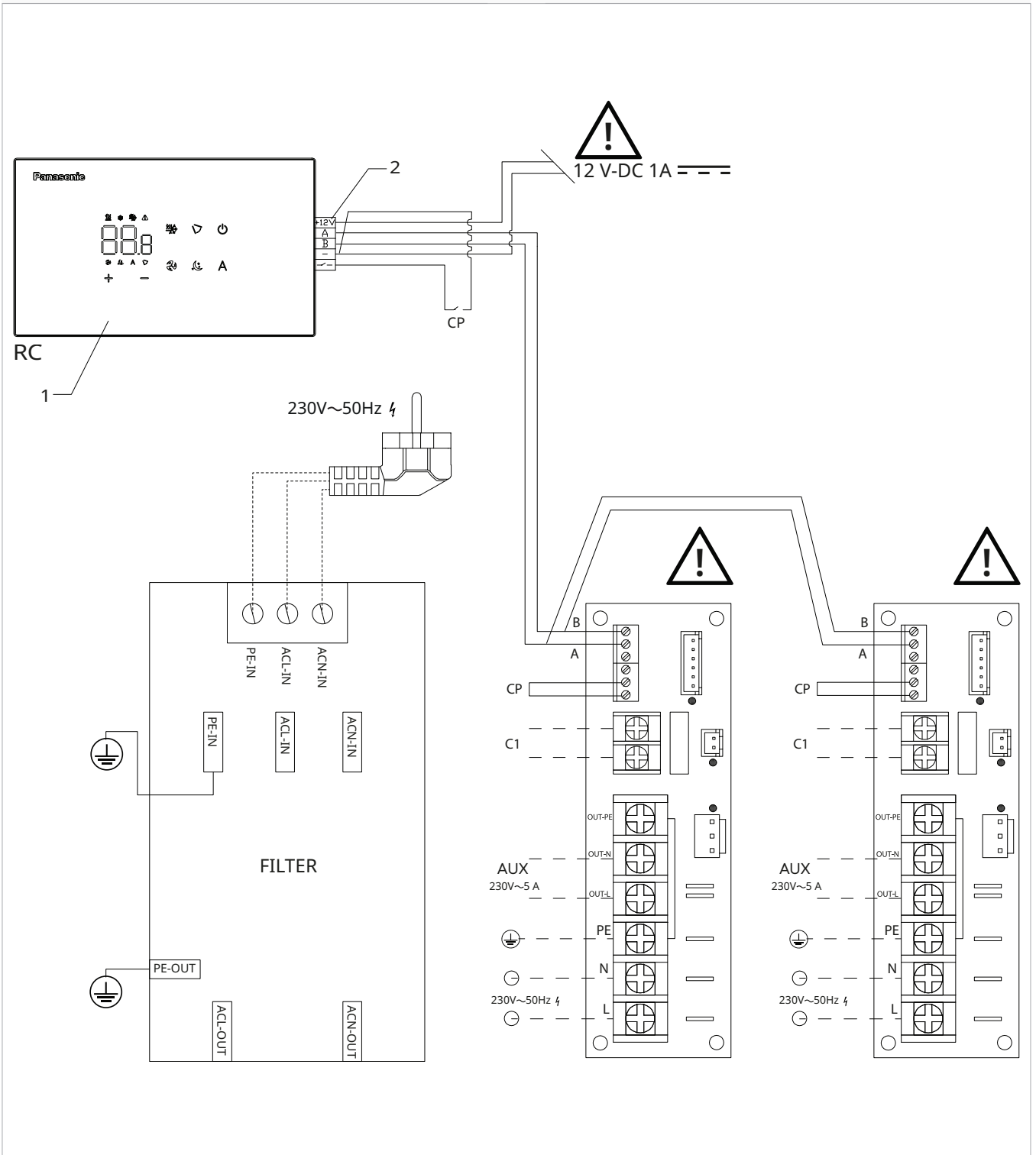

⚠ Reverse A and B for connecting the wall control panel with the boards.

⚠ Power for the control is to be supplied through a 12 V-DC 1A power supply (not field supplied).

11.5 Connections

11.5.1 Preliminary warnings

⚠ The terminals for connecting the control panel and the presence contact CP are inserted in a plastic bag and placed inside the electrical box.

1. Terminal blocks

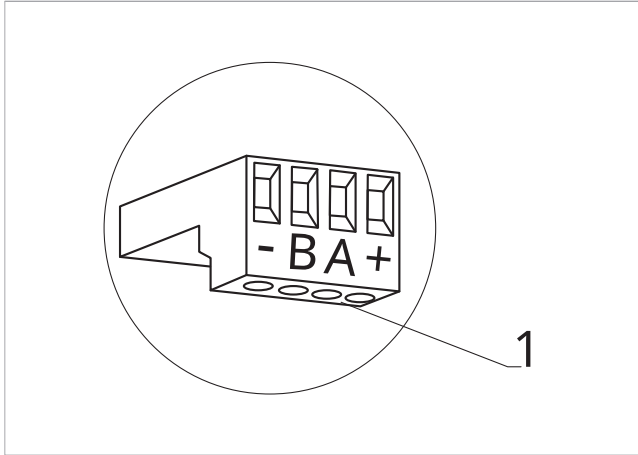

The terminals accept:

- rigid or flexible wires with a 0.2 to 1 mm² cross-section
- rigid or flexible wires with 0,5 mm² cross-section if two wires are connected to the same terminal block
- rigid or flexible wires with 0,75 mm² cross-section if the wires have wire end ferrules with a plastic collar

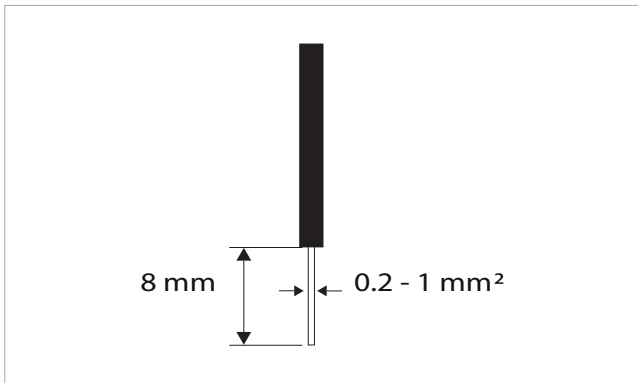

To connect the cables:

- ▶ strip 8 mm of the wire
- ▶ if the wire is rigid, you can insert it easily whereas
- ▶ if it is flexible, use appropriate crimp terminals
- ▶ push the wire in completely
- ▶ check the right fixing by pulling it gently

11.5.2 Control Panel

⚠ The control panel for wall control must be ordered separately.

Terminal block position:

1. Terminal block (Back view panel)

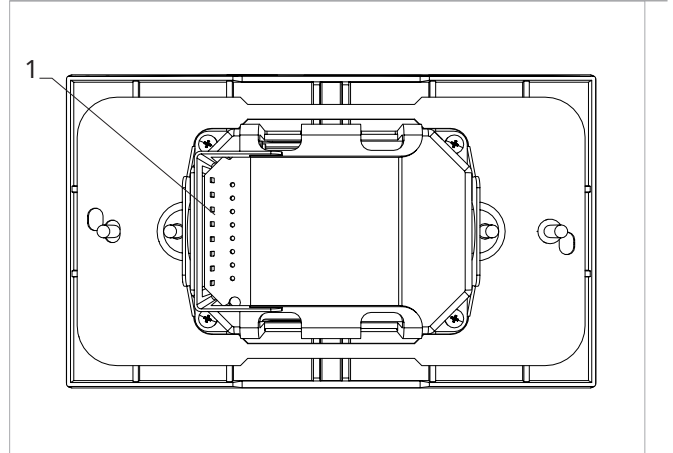

To make the connections:

- ▶ connect the + - power supply wires to a 12 V-DC 1A power supply
- ▶ connect the Modbus serial connection cables to terminals A and B

⚠ Reverse A and B for connecting the wall control panel with the board.

11.5.3 Presence contact CP

Through this device it is possible to connect an external control signal that inhibits the operation of the control signal, for example:

- opening window contact
- remote on/off
- infrared presence sensor
- activation badge

Function

The contact is normally open (NO).

- ▶ when closing the CP contact, connected to a potential-free contact, the device switches to stand-by mode

CP appears on the display.

- ▶ At the touch of a button on the display the symbol ⚠ flashes.

⊖ It is forbidden to connect the CP input to that of another unit electronic board. Use separate contacts.

The CP presence contact can be configured for heating and cooling operation via the "To select digital input" *p. 67* settings menu item (digital input).

11.5.4 RS485 Serial Connection

The wall-mounted remote control can be connected through an RS485 serial line to one or more devices, up to a maximum of 16.

The devices must be equipped with an electronic board suitable for remote control.

For the connection:

- ▶ follow the indication on the connection diagram
- ▶ connect respecting the polarity indication A and B

- ⚠ Use a two core cable shielded cable suitable for the RS485 serial connection with a minimum section of 0,35 mm².
- ⚠ Keep the two core cable separate from power supply cable by a minimum of 50 mm.
- ⚠ Create a wire path in order to minimize the length of the lead wire.

- ⚠ Complete the line with the 120 Ω resistor.
- ⊖ It is forbidden make star connections.





11.5.5 Extended display

- ⚠ To enable device connectivity and enable selection of fan power level, the display must be extended. See section "Extended display" p. 67.



11.6 Functions

11.6.1 Basic menu

To access the basic menu

- ▶ with the display off, hold down  for 10 seconds
The device turns on and  appears
- ▶ keep pressed until the indication  appears
- ▶ release the  key
The symbol  appears

To navigate in the menu

- ▶ use the icons  

To select a menu item and to confirm the changes made

- ▶ press the icon 
Confirming the change takes you to the next item.

To exit the menu

- ▶ press the icon  for 10 seconds
- ▶ or wait 30 seconds

- ⚠ After 30 seconds from the last action, the display exits the menu and the changes made are saved automatically.

Menu items

ot: AIR probe offset (air probe setting)

ur: Value read by the R.H. sensor

ut: Probe Offset PT4

uS: Humidity setpoint

uI: Humidity hysteresis

CF: Scale





ub: Buzzer volume

uu: Wi-Fi reset

up: Wi-Fi pairing

Set AIR probe offset





To set the air probe offset

- ▶ select 
- ▶ press  to change settings
- ▶ increase or decrease the value with the icons  
- ▶ press  to confirm
*By default it is set to -2,5°C.
The setting range is from a minimum of -12.0 °C to a maximum of 12.0 °C.*

Set probe offset RH





- ⚠ Modify only after real deviations from an actual measurement has been established with professional equipment.

To set the RH probe offset

- ▶ select 
- ▶ press  to change settings
- ▶ increase or decrease the value with the icons  
- ▶ press  to confirm
By default it is set to -2,5.





Set the humidity setpoint

To set the humidity setpoint

- ▶ select 
- ▶ press  to change settings
- ▶ increase or decrease the value with the icons  
- ▶ press  to confirm
*By default it is set to 50.
The setting range is from 20.0% to 90.0%.*

Setting the humidity hysteresis

To set the humidity hysteresis

- ▶ select 
- ▶ press  to change settings
- ▶ increase or decrease the value with the icons  
- ▶ press  to confirm
By default it is set to 5.

The setting range is from 1 (min) to 30 (max).

Scale

To change the temperature unit of measure

- ▶ select
- ▶ press to change settings
- ▶ select °C or °F
- ▶ press to confirm
By default the temperature unit of measure is °C.

Adjusting the volume

To change the volume

- ▶ select
- ▶ press to change settings
- ▶ increase or decrease the value with the icons
- ▶ press to confirm
By default it is set to 1.
The volume setting range is from 00 (min) to 03 (max).

The volume changes after confirming the modification.

Factory reset

To reset the factory parameters

- ▶ select
- ▶ press to change settings
- ▶ select No to keep current parameters
- ▶ select Yes to reset the factory parameters
- ▶ press to confirm
By default digital input is set to No.

Wi-Fi reset

To reset the Wi-Fi credentials and return the device to its original configuration

- ▶ select
- ▶ press to change settings
- ▶ use the icons in sequence
Appears
- ▶ press
- ▶ appears to reset Wi-Fi credentials.
- ▶ press to confirm
Credentials have been reset.

Activate Wi-Fi

To activate Wi-Fi

- ▶ select
- ▶ press to change settings
- ▶ use the icons in sequence
Appears
- ▶ press
- ▶ appears to enable Wi-Fi pairing.
- ▶ press to confirm

The device remains visible on Aquarea Home App for the first 15 minutes after the device is switched on.

11.6.2 Advanced Menu

To access the setup menu, it is necessary to access the Basic menu. See section "Basic menu" p. 65.

The special functions menu can be accessed via the control panel.

To access the advanced menu

- ▶ from the basic menu press
- ▶ Appears
- ▶ press the key once
Appears
- ▶ press to confirm and log in
The advanced menu is accessed.

To navigate in the menu

- ▶ use the icons

To select a menu item and to confirm the changes made

- ▶ press for 2 seconds
Confirming the change takes you to the next item.

To exit the menu

- ▶ press for about 10 seconds
Appears
- ▶ press for about 10 seconds
The display turns off.

- ▶ or wait 30 seconds after the last action

After 30 seconds from the last action, the display exits the menu and the changes made are saved automatically.

Menu items

Ad: Modbus address (only used when connecting with the Aquarea Home)

Pr: Not used

di: Options for digital input

rH: Not used

rC: Not used

UC: Not used

Ac: Not used

Ah: Not used

Ed: Extended display









Ab: Enabling brightness sensor

Fr: Not used

Set device address for communication



⚠ Used only in case of connection with the Aquarea Home.

To set the Modbus address

- ▶ select 
- ▶ press  to change settings
- ▶ press   simultaneously to change the value shown on the display
The value shown in the display flashes.
- ▶ press  to confirm
- ▶ increase or decrease the value with the icons  
- ▶ press  to confirm
*By default the Modbus address is set to 01.
The setting range is from 01 (min) to 99 (max).*

To select digital input

To change the digital input

- ▶ select 
- ▶ press  to change settings
- ▶ select CP for presence contact (default)
- ▶ select CO to cooling open
- ▶ select CC to cooling close
- ▶ press  to confirm
By default digital input is set to CP.

⚠ For return to the default settings, set the digital input to "CP".

⚠ By selecting one of the other inputs (CO,CC) the seasonality is locked. It is not possible to modify it through the key  of the control.

Extended display

⚠ **Allows device connectivity and enables the selection of the ventilation power level.**

⚠ To use the ventilation speed selection, it is necessary to enable the display extension.





To enable the display extension

- ▶ select 
- ▶ select no to disable
- ▶ select Ys to enable
By default, the device is set to no.

Optical sensor

⚠ By default, the brightness sensor is set.

To disable the brightness sensor:

- ▶ select 
- ▶ press  *Appear Ys.*
- ▶ press 
- ▶ select no
- ▶ press  to confirm
The brightness sensor is disabled.

⚠ The brightness sensor adapts to room lighting.

11.6.3 Alarm display on wall control panel

⚠ In the event of an alarm, the device still maintains active functions.

⚠ Alarm codes are shown on the on-board display. Refer to the "Visualisation of alarms on display" *p. 49* chapter for the complete list.

12. PUTTING IT INTO SERVICE

12.1 Preliminary warnings

- ⚠ **This section is dedicated to the Authorised Service Centre. The features of the Authorised Service Centre are described in chapter "Recipients" p. 6.**
- ⚠ **The initial start-up of the heat pump must be carried out by the Authorised Service Centre.**
- ⚠ **For detailed information on accessories please refer to the "Configuration accessories" p. 78 section.**
- ⚠ The customer must be present when the appliance is tested and informed of the contents of the manual and procedures. After commissioning, the manual and the warranty certificate must be handed over to the customer.
- ⚠ Before start-up, all work (electrical and plumbing connections, filling and venting of air from the plant) must be completed.

12.1.1 Preliminary warnings for R290

- ⚠ The unit uses environmentally friendly R290 refrigerant gas, with a Global Warming Potential (GWP) = 3. Do not release R290 gas into the atmosphere.
- ⚠ R290 refrigerant gas is flammable and odourless.
- ⚠ Do not place flammable objects (spray cans) within 1 metre of the air outlet.
- ⚠ All precautions concerning the treatment of the refrigerant must be observed following the regulations in force.
- ⚠ Avoid proximity to sources of ignition in continuous operation (open flames, gas appliances, electric stoves, lighted cigarettes, etc.).
- ⚠ Do not use any means to speed up the defrosting process.

- ⊖ Smoking in the vicinity of the appliance is prohibited.
- ⊖ Using a mobile phone near the appliance is prohibited.
- ⊖ It is forbidden to use means to accelerate the defrosting process or for cleaning other than those recommended.
- ⚠ Perform the following checks:
 - carry out safety checks to ensure that the risk of combustion is minimised
 - avoid working in confined spaces
 - delimit the area around the workspace
 - ensure safe working conditions around the area by controlling flammable material

Leak detection

- ⊖ The use of combustion fluid detectors, e.g. a halide torch or other detection system using an open flame, is forbidden.
- ⚠ Follow the instructions below for leak detection:
 - use electronic detectors to detect flammable refrigerants
 - check that the detectors are properly calibrated before use
 - calibration operations must be carried out in an area free from refrigerant
 - make sure that the detector is not a potential source of combustion and that it is suitable for the refrigerant used
 - all open flames must be removed if a leak is suspected
 - in the event of a leak requiring brazing, it is mandatory to recover all the refrigerant from the system or isolate it (by means of shut-off valves) in a part of the system away from the leak
- ⚠ The use of silicone sealant may affect the effectiveness of some types of leak detectors.

12.2 First start-up

12.2.1 Preliminary checks

Before proceeding with start-up, check that:

Functional

- all safety conditions have been met
- the unit has been properly secured to the supporting surface or wall
- the minimum technical clearances have been respected

Hydraulics

- the hydraulic connections have been made according to the instructions in the manual
- the hydraulic plant has been filled and vented
- the system pressure is between 1 and 2 bar with the circulation pump switched off
- the loading tap is closed
- the shut-off valves of the hydraulic circuit are open
- condensate drainage has been carried out correctly
- the dirt separator or mesh filter is installed and clean

- ⊖ Operating the unit without adequate water filtration installed and clean is forbidden.

Electrics

- the cross-section of the power supply cables is suitable for the absorption of the appliance and the length of the connection made
- the earthing was performed correctly
- the electrical connections have been established correctly
- all electrical connections are properly secured and all terminals properly tightened
- the voltage is within a tolerance of 10% of the rated voltage of the unit
-
- the control panel has been installed and connected correctly

Wall-mounted control (optional)

- display extension has been enabled, see paragraph "Extended display" p. 67

12.2.2 Water quality checks

The technician must measure the reference values of the water in the system with special test kits.

- ⚠ Take the necessary steps to achieve the indicated limits if the total hardness is greater than 15 °F or some top-up water reference values are not within the limits indicated.
- ⚠ Water from wells or groundwater that is not from an aqueduct should always be carefully analysed. If necessary, condition with appropriate treatment systems.
- ⚠ If a softener is installed, in addition to following the Manufacturer's instructions, adjust the outlet water hardness to not less than 5 °F (by performing pH and salinity tests) and check the outlet chloride concentration after adjusting the resins.

12.2.3 Powering up

- ⚠ **If the unit has been transported horizontally and only then placed vertically, wait at least 2 hours before powering the appliance.**

To start the unit:

- ▶ set the main switch to ON
- ▶ The display will light up in a few seconds.

To start the unit:

- ▶ press the key 

- ⚠ **Refer to the Control Panel Manual to carry out the operations.**

12.2.4 Series/parallel connection type check

- ⚠ When upgrading existing systems, the hydraulic connection between the various units may be in series or parallel according to the system type. This information should have already been assessed during the design phase with the survey of the existing system.

- ⚠ The 2/3-way valve kit set indifferently for either 3-way or 2-way operation must be installed in the case of systems with parallel connection.

- ⚠ The 2/3-way valve kit set for 3-way operation must be installed in the case of systems with series connection. Otherwise, when one unit stops, the units installed downstream will shut down due to lack of flow.

To check correct operation:

- ▶ close isolation valve on a unit
- ▶ check that in all units of the same branch the flow of water has stopped
- ▶ check whether other units in the system are without water flow

- ⚠ Checks by the installer.

12.2.5 Start menu





The control of the units Aquarea Loop has a dedicated Start menu with specific function for:

- Flow meter water flow measurement
- Measuring the water inlet/outlet temperature
- Setting the valve all open
- Setting the valve all closed
- Setting the modulating valve at nominal flow rate





- ⓘ See section "Touchpad - Menu structure" p. 42.

12.2.6 Loop flow calibration and balancing

Accessing the Start menu

- ▶ press  to switch the unit on
- ▶ press   at the same time for about 10 seconds
UE appears, the start menu opens.
- ▶ press   for 10 seconds
FF appears, the Start menu opens.





Forced valve opening

- ▶ press  to log in
- ▶ use  
- Select option oP - Forces full opening of the valve.*
- ▶ press  to confirm

- ⚠ Wait at least 2 minutes for the valve to open fully.

Checking the water flow rate

- ⚠ Check that the system pump is on at maximum head.
- ⓘ Refer to the installer's manual for using a head-controlled inverter pump.

- ▶ press 
FF appears.
- ▶ use  
- ▶ select option FL - Water flow rate (L/min)
- ▶ press  to log in
- ▶ read the flow rate value on the display
- ▶ record the collected data on the start-up form

- ⚠ Repeat the procedure for each appliance.

Use the flow calibration table below to check that the flow rate is within the correct values.

Flow calibration table

Models	u.m.	P-CWSL**		
		10	20	30
Hydraulic data				
Minimum water flow rate	L/min	2,0	4,0	6,0
Nominal flow rate	L/min	4,0	8,0	12,0
Maximum water flow rate	L/min	6	12	18

If all terminals are within the values in the table:

- ▶ no action is necessary

If all terminals have the flow rate value higher than the maximum:

- ▶ reduce the flow rate of the loop pump
- ▶ repeat the check until within range

If all terminals have the flow value below the minimum:

- ▶ check the loop pressure drop
- ▶ review pump sizing

In case of mixed situations:

- ▶ start with the unit with the highest flow rate
- ▶ adjust the holder of the units with the highest flow rate to within the reference range
- ▶ calibrate each unit only once
- ▶ check that the most disadvantaged unit is within the reference range

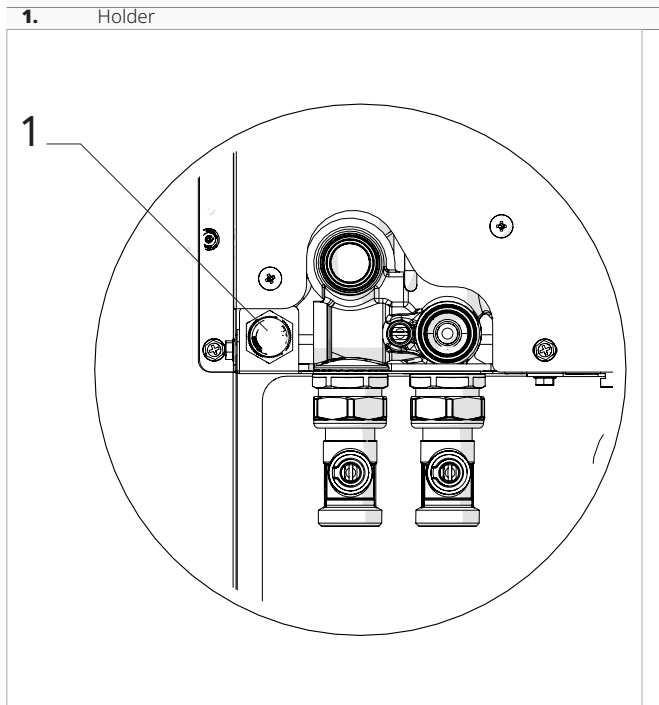

Before exiting the Start menu to remove the forced valve opening

- ▶ once the flows are adjusted
- ▶ press to confirm
- ▶ select FF
- ▶ press to access
- ▶ select of
- ▶ press to confirm

The forced opening is automatically removed after 2 hours.

Wait a few minutes and check the nominal value with the table.

To exit the Start menu

- ▶ press *FF appears.*
Exits the Start menu.

12.2.7 Lockshield valve adjustment

The lockshields supplied with the hydraulic kits provide an adjustment that balances the system load losses. To ensure a correct adjustment and balancing of the circuit, follow the procedure indicated below:

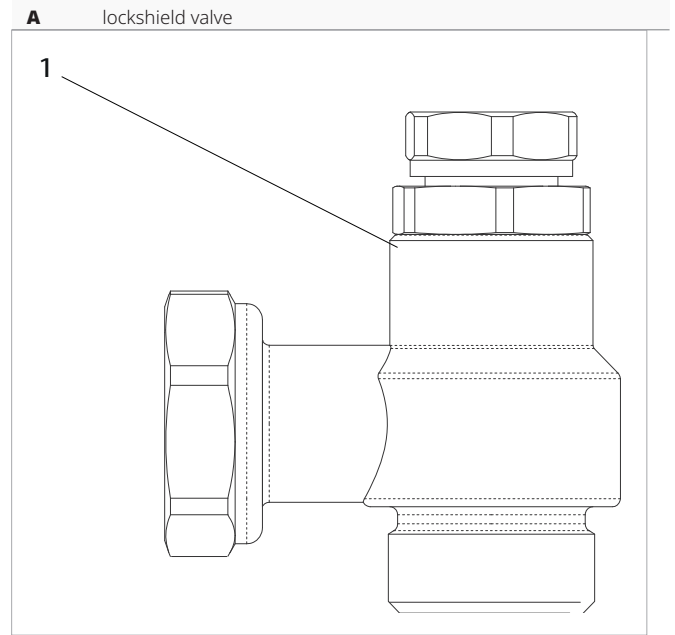

- ▶ use a screwdriver
- ▶ loosen and remove the slotted grub screw inside the hexagonal head
- ▶ use a 5 mm Allen key
- ▶ close the adjustment screw

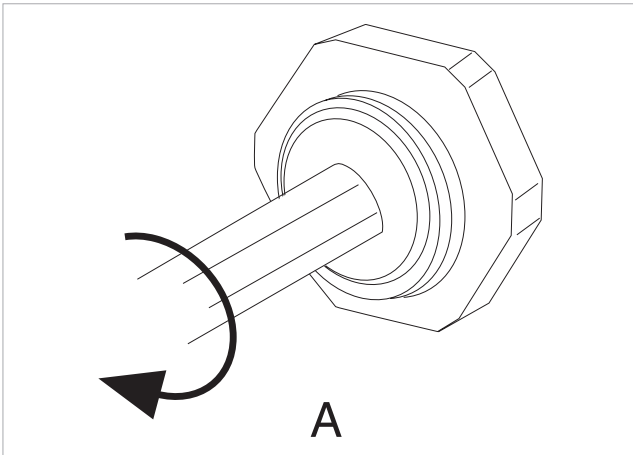

- ▶ re-tighten the slotted grub screw
- ▶ mark the reference point for the adjustment with an "x" (B)

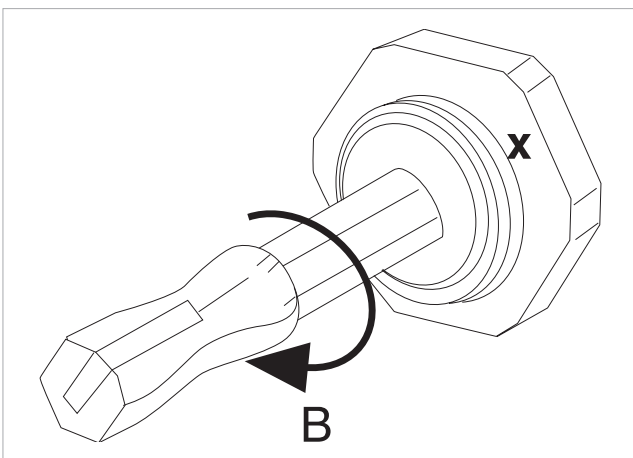

- ▶ align the screwdriver with the "x"
- ▶ then open with a number of turns (C) according to diagram Δp-Q

⚠ The number of turns refers to the micrometric screw.

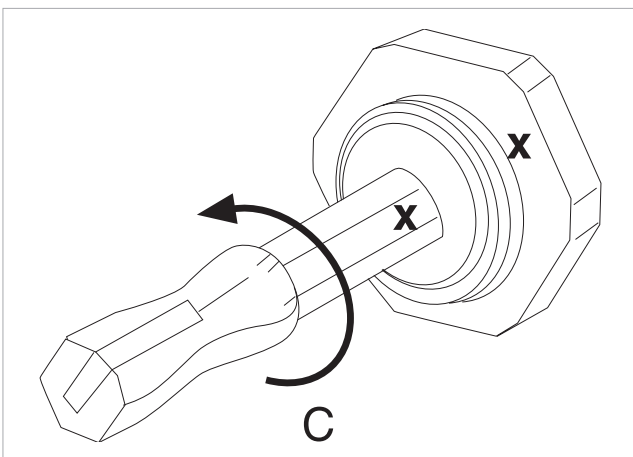

- ▶ fully open the screw

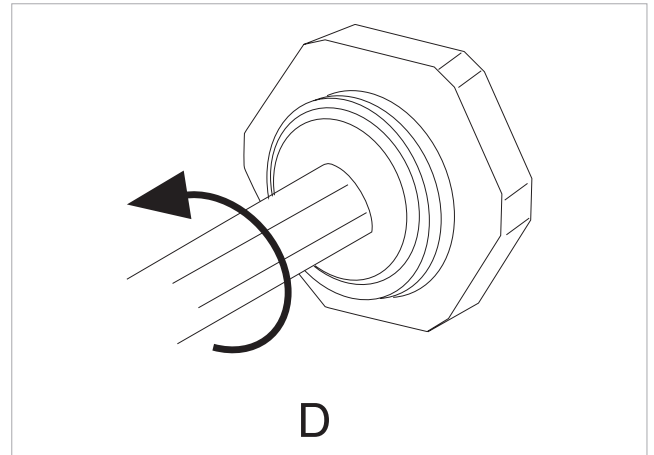

Now the pre-adjustment has been set and will not change if there are repeated openings or closings with the Allen key.

12.2.8 Checks with the machine switched on

After starting up, check that

Functional

- verify the different modes of operation
- check that the appliance performs a shutdown and subsequent restart
- switch the appliance off and on again and check that it restarts correctly
- check that the appliance operates in the recommended operating conditions (see technical data table)

⚠ Refer to the Control Panel Manual to carry out the operations.

Water temperature check in Heating mode

- ▶ set the set point to maximum temperature
- ▶ enter the view menu
- ▶ access to FL
- ▶ check that the water flow rate is correct see table "Flow calibration table" *p. 70*
- ▶ access to CO
- ▶ check that the value is greater than 0
- ▶ log on in and ou
- ▶ check that ou is less than in

Water temperature check in Cooling mode

- ▶ set the set point at minimum temperature
- ▶ enter the view menu
- ▶ access to FL
- ▶ check that the water flow rate is correct see table "Flow calibration table" *p. 70*
- ▶ access to CO
- ▶ check that the value is greater than 0
- ▶ log on in and ou
- ▶ check that ou is greater than in

Electrics

- the current draw of the compressor is lower than the maximum indicated in the technical specifications table
- the supply voltage value is within the set limits and does not fall below the nominal value during compressor operation -10 %

Hydraulics

- the hydraulic circuit is completely deaerated.

⚠ Carry out the measurements indicated on the Test Sheet for the first start-up.

Presence of air

Check that no air pockets are still present once the electrical connections have been established and the circulation pump has been switched on.

In the presence of air pockets:

- stop the pump several times

- vent again

⚠ To avoid dangerous cavitation that could damage the pump and make the entire appliance less efficient, the suction pressure, with the pump on, measured by the pressure gauge on the appliance, must not be less than 0.6 bar.

⚠ Carry out the priming procedure for the injection pump kit if the injection pump kit is present. See paragraph "Putting it into service " p. 79.

12.3 Plant delivery

Once all the checks and controls on the correct operation of the plant have been completed, the installer must explain the following to the user:

- the basic functional characteristics of the appliance
- the instructions for use
- the routine maintenance

12.4 Long period shut-down

The following operations must be carried out if the air-to-water heat pump is not used for a long time:

- ▶ disable the device
- ▶ turn the master switch of the appliance to position 0-, OFF.

After switching off the appliance:

- ▶ switch off the indoor terminal units by setting the switch of each appliance to the "Off" position
- ▶ set the main system switch to "Off"
- ▶ isolate the water supply

⚠ Contact the Authorised Service Centre.

⚠ If the outside temperature may fall below zero degrees centigrade, with the likelihood of frost, the hydraulic plant must be drained or antifreeze liquid (e.g. ethylene glycol) must be added in the doses recommended by the manufacturer.

To restart the heat pump after it has been out of operation for a long time, contact the Service Centre.

12.5 Draining the plant

The appliances are not equipped with a drain cock, it is necessary to provide one on a pipe connecting to the plant at a point near and below the appliance.

12.5.1 Preliminary warnings

⚠ All operations must be carried out with the machine stopped and disconnected from the power supply.

12.5.2 Draining

Before starting the emptying operation:

- ▶ check that the plant water filling loop cock is closed

To drain the plant:

- ▶ open the drain cock on the outside of the appliance
- ▶ open all the air purge valves of the plant and its terminals

13. MAINTENANCE

13.1 Preliminary warnings

⚠ This section is dedicated to the Authorised Service Centre. The features of the Authorised Service Centre are described in chapter "Recipients" p. 6.

⚠ For detailed information on accessories please refer to the "Configuration accessories" p. 78 section.

⚠ This unit contains fluorinated greenhouse gases covered by the Kyoto Protocol. Maintenance and disposal operations must be carried out by qualified personnel only.

Before each cleaning and maintenance intervention:

- ▶ disconnect the device from the power supply by turning the system main switch to "OFF"
- ▶ wait for the components to cool down in order to avoid any burns

⊖ Carrying out any technical or cleaning work before disconnecting the unit from the power supply is forbidden.

⚠ Make sure that there is no voltage before operating.

⚠ After completing the maintenance work, the unit must be restored its original condition.

⚠ Handle refrigerant with care. Leaking refrigerant can cause freezing.

13.1.1 Preliminary warnings for R290

⚠ The unit uses environmentally friendly R290 refrigerant gas, with a Global Warming Potential (GWP) = 3. Do not release R290 gas into the atmosphere.

⚠ R290 refrigerant gas is flammable and odourless.

⚠ Do not place flammable objects (spray cans) within 1 metre of the air outlet.

⚠ All precautions concerning the treatment of the refrigerant must be observed following the regulations in force.

⚠ Avoid proximity to sources of ignition in continuous operation (open flames, gas appliances, electric stoves, lighted cigarettes, etc.).

⚠ If refrigerant gas escapes, ventilate the room abundantly and leave. Call the Authorised Service Centre or professionally qualified personnel as soon as possible and do not intervene on the appliance yourself.

⊖ Smoking in the vicinity of the appliance is prohibited.

⊖ Using a mobile phone near the appliance is prohibited.

⊖ It is forbidden to use means to accelerate the defrosting process or for cleaning other than those recommended.

⚠ Perform the following checks:

- carry out safety checks to ensure that the risk of combustion is minimised
- avoid working in confined spaces
- delimit the area around the workspace
- ensure safe working conditions around the area by controlling flammable material

Leak detection

⊖ The use of combustion fluid detectors, e.g. a halide torch or other detection system using an open flame, is forbidden.

⚠ Follow the instructions below for leak detection:

- use electronic detectors to detect flammable refrigerants
- check that the detectors are properly calibrated before use
- calibration operations must be carried out in an area free from refrigerant
- make sure that the detector is not a potential source of combustion and that it is suitable for the refrigerant used
- all open flames must be removed if a leak is suspected
- in the event of a leak requiring brazing, it is mandatory to recover all the refrigerant from the system or isolate it (by means of shut-off valves) in a part of the system away from the leak

⚠ The use of silicone sealant may affect the effectiveness of some types of leak detectors.

13.2 Once-a-year operations

The once-a-year maintenance plan includes the following operations and checks and must be carried out by the Authorised Service Centre or by qualified personnel.

13.2.1 Routine maintenance of the unit

Hydraulic circuit

Check:

- water circuit filling
- hydraulic circuit filter cleanness
- safety device control
- absence of air in the circuit
- that the water flow rate to the heat exchangers is always constant
- the glycol percentage, if any is present

Electric circuit

Check:

- electrical supply voltage
- electric draw
- tightness of connections
- that there is no damage or excessive wear on the electrical cables
- the seals and sealing materials have not deteriorated to such an extent that they are no longer suitable for preventing the development of flammable atmospheres inside
- correct fixing of the cable clamps
- safety devices

Mechanical checks

Check:

- the tightness of the screws, the compressors and the electrical box and the external panelling of the unit
- the conditions of the structure

⚠ Poor fastenings cause abnormal noises and vibrations.

⚠ Treat any rusty parts with paints suitable to eliminate or reduce the rust.

Cleaning

- clean the air heat exchanger coil
- clean the condensate drip tray
- clean cosmetic covering elements

⚠ Use brushes or tools that do not involve risks of perforating the exchangers or igniting flames to clean the exchangers.

Refrigeration checks

Make sure that:

- the marking on the equipment must remain visible and legible. Illegible markings and graphics must be corrected
- the thermodynamic values are within the nominal parameters

The company responsible for maintenance must keep a logbook in which the following information is recorded:

- the technician who performed the maintenance or repair,
- the dates and results of the checks,
- the quantity and type of fluorinated gas used,
- any quantities added or recovered during servicing, repair or final disposal.

⚠ Filling the refrigeration circuit with a refrigerant other than the one indicated is forbidden. Using a different refrigerant gas can cause serious damage to the unit.

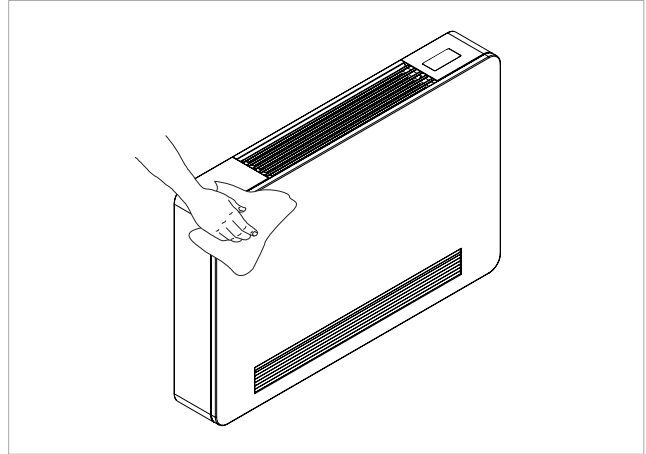
13.2.2 External cleaning

Clean the external surfaces with a soft damp cloth.

⚠ Disconnect the unit from the power supply before each cleaning and maintenance intervention by setting the main power supply switch to off.

⚠ Do not use abrasive sponges, or abrasive or corrosive detergents, as you might damage the painted surfaces.

13.2.3 Cleaning the filters

Clean the air filter after a period of continuous use and according to the concentration of impurities in the air, or when you wish to start-up the appliance after a period of inactivity.

⚠ The filter is located in the bottom part of the appliance.

⚠ Wait for the components to cool down in order to avoid any burns.

⚠ Pay attention to the sharp edges.

1. Filter

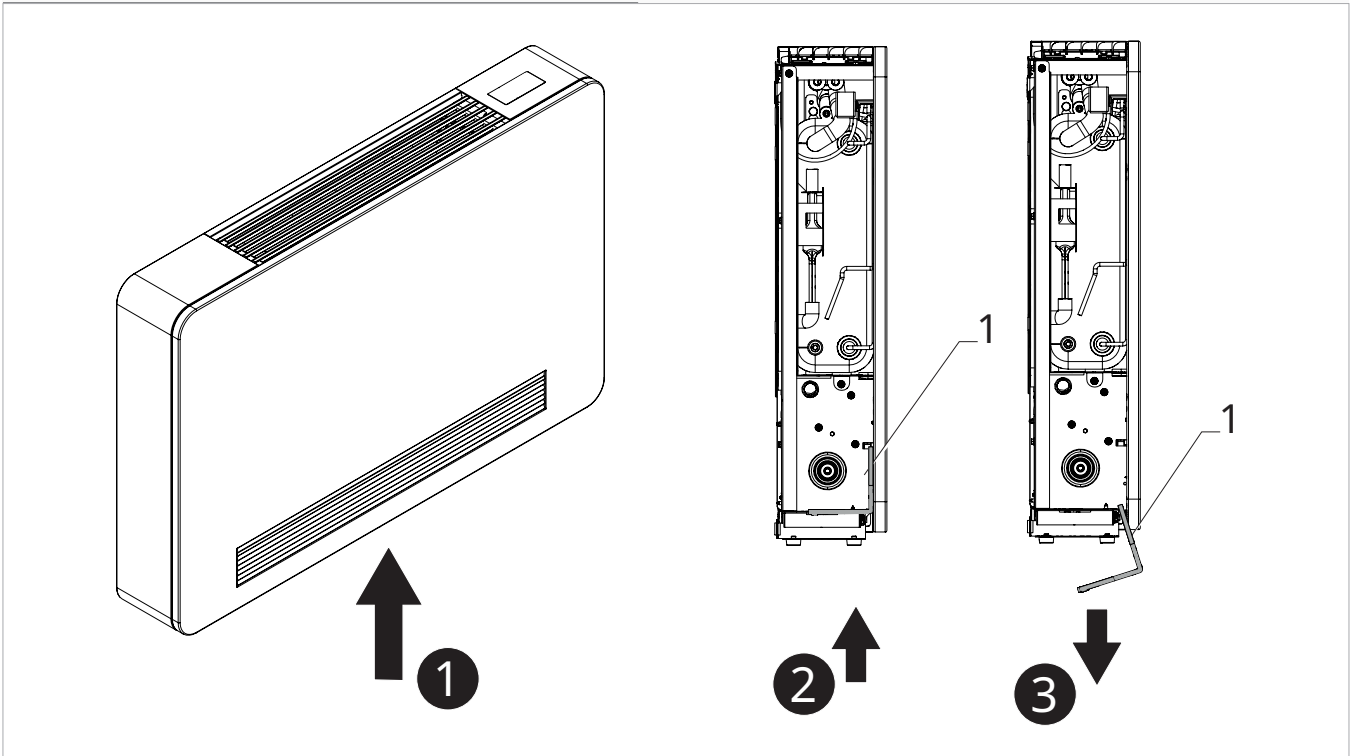
**To remove the filter:**

- ▶ Push up the plastic tabs on the bottom of the filter
- ▶ Unhook the filter from its housing
- ▶ remove the filter by pulling it downwards

To reassemble the filter:

- ▶ proceed in reverse order

- ⚠ Check that the filter is fitted correctly.
- ⊘ It is forbidden to use the device without its mesh filter.
- ⚠ Do not use detergents or solvents.

14. TROUBLESHOOTING

14.1 Troubleshooting table



⚠ Check for alarms on the on-board display. In the event of a malfunction, please refer to the following table. If, after performing the suggested checks, the prob-

lem is not solved, please contact the Authorised Technical Assistance.

Anomalies	Possible causes	Remedies
The appliance doesn't switch on	No power supply	Check there is power supply (by turning a light on, for example).
		Check that the thermal-magnetic circuit breaker used exclusively to protect the appliance has not been tripped (if it has, reset it). If the problem repeats immediately, please call the Service Centre and avoid trying to make the appliance work.
The appliance does not cool/heat adequately.	The temperature set is too high or too low.	Check and, if necessary, adjust the temperature setting on the remote control
	The air filter is clogged	Check the air filter and clean it if necessary
	Check that there are no other obstacles to the air flow both inside and outside the appliance.	Remove anything that might block the air flow.
	The heating and cooling load has increased (for example, a door or a window has been left open or an appliance has been installed in the room which generates a lot of heat).	Try to reduce the heating and cooling load of the room following instructions below: Cover large windows exposed to sunlight with curtains or with external maskings (blinds, porches, reflecting films, etc.); The air conditioned room must remain closed for as long as possible; Avoid turning on halogen lamps or other high energy consumption appliances such as small ovens, steam irons, hot plates etc.).

14.2 Visualisation of alarms on display

 In the event of an alarm, the device still maintains active functions.

 A flashing  symbol and alarm code are displayed on the touchpad to indicate alarms.

Code	Alarm description	Solution
Er01	Ambient temperature sensor disconnected or faulty	If the alarm does not automatically reset, disconnect and reconnect the power supply. If the alarm does not reset, contact the Authorised Service Centre.
Er02	Air heat exchanger temperature sensor error	If the alarm does not automatically reset, disconnect and reconnect the power supply. If the alarm does not reset, contact the Authorised Service Centre.
Er03	Water temperature sensor error at plate heat exchanger outlet	If the alarm does not automatically reset, disconnect and reconnect the power supply. If the alarm does not reset, contact the Authorised Service Centre.
Er04	Plate heat exchanger temperature sensor error	If the alarm does not automatically reset, disconnect and reconnect the power supply. If the alarm does not reset, contact the Authorised Service Centre.
Er05	Faulty internal fan motor	Check that the filter is fitted correctly. Disconnect and restore power to the appliance. If the malfunction persists, contact the Authorised Service Centre.
Er06	Water temperature sensor error at plate heat exchanger inlet	If the alarm does not automatically reset, disconnect and reconnect the power supply. If the alarm does not reset, contact the Authorised Service Centre.
Er07	Driver communication error	Disconnect and restore power to the appliance. If the malfunction persists, contact the Authorised Service Centre.
Er08	Compressor discharge sensor error	If the alarm does not automatically reset, disconnect and reconnect the power supply. If the alarm does not reset, contact the Authorised Service Centre.
Er09	Communication error with remote thermostat	Check that thermostat is switched on and that the set functions are activated on the appliance. Otherwise, contact the Authorised Service Centre.
Er10	Condensate level in the bowl too high	The condensate drain is not functioning properly, contact the Authorised Service Centre.
CP	CP contact activation	Open contact. The appliance only switches on when the contact is closed, check the terminal connection.
Er12	Driver error	Disconnect and restore power to the appliance. If the malfunction persists, contact the Authorised Service Centre.
CE	Communication error between main circuit board and display	You cannot see the function on the display, please contact the Authorised Service Centre.
Er14	No water flow in the plate heat exchanger (loop)	Check hydraulic pressure and correct circulation. If the malfunction persists, contact the Authorised Service Centre.
Er16	No refrigerant / 4-way valve malfunction	Disconnect and restore power to the appliance. If the malfunction persists, contact the Authorised Service Centre.
Er17	Driver parameter error	Disconnect and restore power to the appliance. If the malfunction persists, contact the Authorised Service Centre.
Er18	Plate heat exchanger fluid flow error	Disconnect and restore power to the appliance. If the malfunction persists, contact the Authorised Service Centre.
Er21	Inverted plate heat exchanger fluid flow	Operation of the appliance is still guaranteed. Contact the installer and reverse the pipes.
Er22	Incorrect supply voltage	Disconnect and restore power to the appliance. If the malfunction persists, contact the Authorised Service Centre.
BL	Key lock	To unlock the display, press simultaneously  for 3 seconds.
 *	Water inlet temperature > 55 °C or < 6 °C	Check for proper water circulation in the appliance, the opening of any zone valves and the operation (and consistent hot/cold setting) of the heat pump.
* flashing		

15. CONFIGURATION ACCESSORIES

15.1 Basic hydronic kit

1. Basic hydronic kit

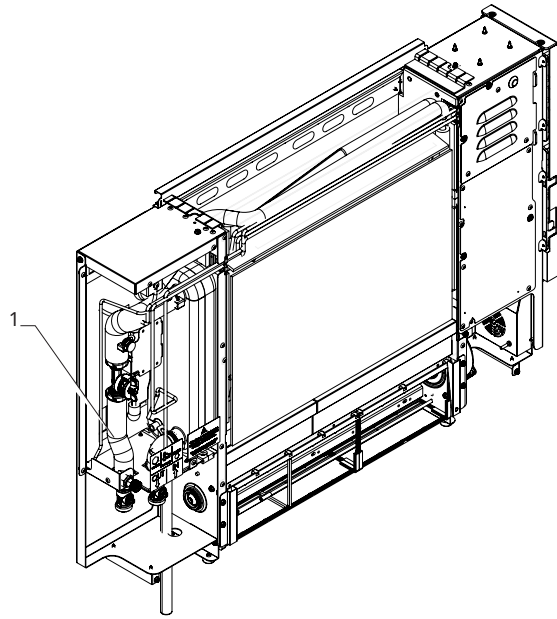

15.2 2/3-way on/off valve kit

1. 2/3-way on/off valve kit

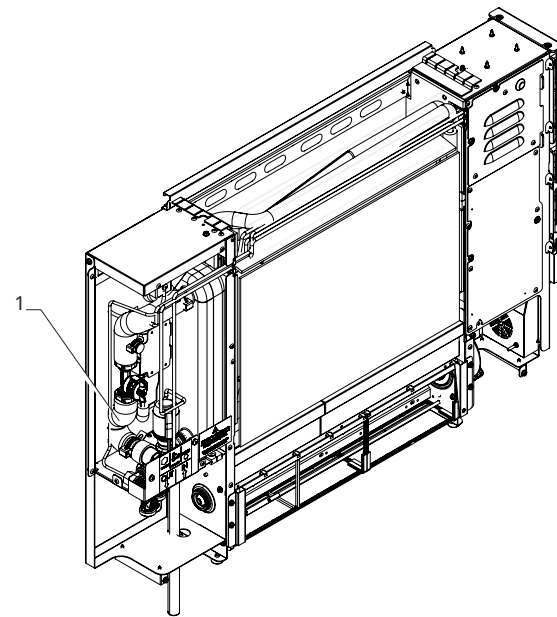

15.3 2/3-way modulating valve kit

1. 2/3-way modulating valve kit

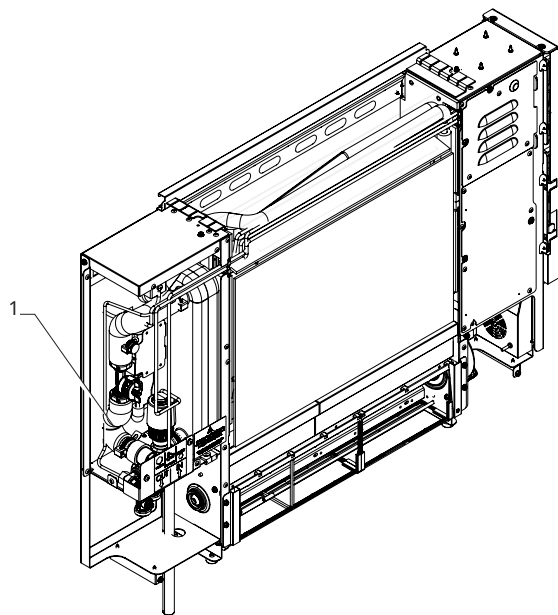

15.4 Injection pump kit

The injection pump kit is used in system situations in which it is not possible to drain condensate through a draining system.

The kit injects condensate into the hydraulic circuit. An overpressure relief system must be provided.

1. Injection pump kit

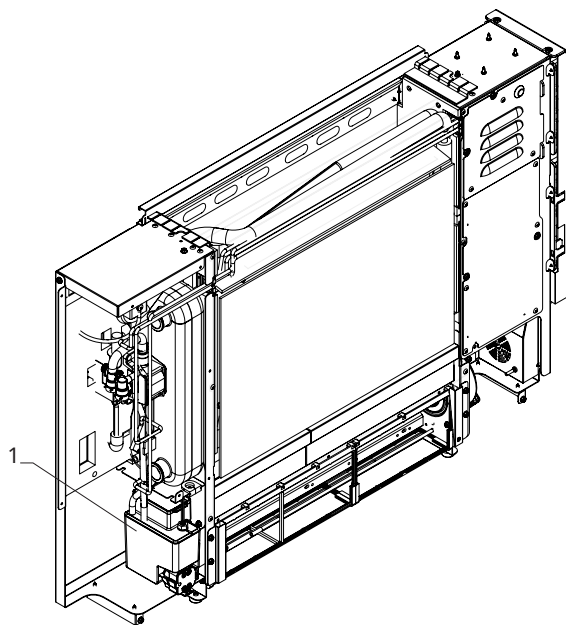







15.4.1 Putting it into service

To access the Start menu



- ▶ press \oplus \ominus at the same time for about 10 seconds
Compare UE.

- ▶ press \oplus \ominus at the same time for about 10 seconds
FF appears.

To activate the priming procedure of the injection pump kit

- ▶ press in sequence 
iC appears.
- ▶ press  to log in
- ▶ press in sequence 
oF appear.
- ▶ press  to confirm
- ▶ fill the kit reservoir with 150 ml of water
- ▶ check that iC is still present on the display
- ▶ press  to log in
- ▶ press in sequence 
St appears.
- ▶ press  to confirm
After a few seconds the pump will start to make noise.
Wait until the noise subsides. This means that the pump has primed. If not, check the connections and repeat the procedure.



To activate the condensate drain

- ▶ check that iC is still present on the display
- ▶ press  to log in
- ▶ press in sequence 
on appears.

 The control panel stores the last menu item used. The last position used appears at the next access.

- ▶ press  to confirm
The pump will start to drain water into the system and will automatically stop when the water level is sufficient.

To check the level

- ▶ check that iC is still present on the display
- ▶ press  to log in
- ▶ press in sequence 
Appear LE.
- ▶ press  to confirm
The water level will begin to slowly decrease until it reaches 0.
If the display shows hi or lo, check the system pressure.

To exit the menu

- ▶ press 3 times 

After 5 minutes of inactivity all settings are disabled and return to standard operation.

16. TECHNICAL INFORMATION

16.1 Technical data

Models	u.m.	10	20	30
Cooling performance (W 30 °C; A 27 °C)				
Maximum cooling capacity	kW	1,20	1,70	3,00
Nominal cooling capacity	kW	1,12	1,52	2,59
Minimum Cooling Capacity	kW	0,20	0,30	0,60
Rated power consumption	kW	0,2	0,3	0,5
EER		5,60	4,90	5,51
SEER		5,50	6,10	7,90
Heating performance (W 20 °C; A 20 °C)				
Maximum heat output	kW	1,40	2,30	3,60
Nominal heat power	kW	1,04	2,08	3,10
Minimum heat output	kW	0,40	0,40	0,80
Rated power consumption	kW	0,2	0,3	0,5
COP		5,78	6,12	6,08
SCOP		6,44	6,92	6,74
Electrical data				
Power Supply	V/ph/Hz	230/1/50	230/1/50	230/1/50
Maximum absorbed power	kW	0,40	0,89	1,15
Maximum absorbed current	A	1,74	3,87	5,01
Aeraulic data				
Ventilation speed	Nr.	4 (+ super-minimum silent)	4 (+ super-minimum silent)	4 (+ super-minimum silent)
Maximum air flow	m ³ /h	160	330	500
Medium air flow	m ³ /h	105	205	305
Minimum flow rate	m ³ /h	50	100	175
nominal air flow rate	m ³ /h	145	295	440
General characteristics				
Type of compressor		Rotary DC Inverter	Rotary DC Inverter	Rotary DC Inverter
Sound data				
Maximum sound pressure level	dB(A)	40	42	44
Nominal sound pressure	dB(A)	33	34	35
Minimum sound pressure level	dB(A)	28	29	31
Maximum sound power level	dB(A)	48	50	52
Hydraulic data				
Hydraulic connections	" EK	3/4	3/4	3/4
Nominal flow rate for heating	L/min	3,7	7,7	12,0
Nominal flow rate for cooling	L/min	4,5	5,2	9,0
Nominal pressure drop in heating mode	kPa	6,80	11,20	12,50
Nominal pressure loss in heating mode with flow control valve	kPa	7,80	14,20	20,50

Models	u.m.	10	20	30
Nominal pressure drop in cooling mode	kPa	4,80	5,40	7,50
Nominal pressure drop in cooling mode with flow control valve	kPa	5,40	6,70	11,80
Refrigerant gas data				
Type of refrigerant		R290	R290	R290
Quantity of refrigerant	kg	0,10	0,14	0,15
Product dimensions and weight				
Width	mm	775	975	1225
Height	mm	641	641	641
Total depth	mm	144	144	144
Empty weight	kg	35,0	40,0	45,0
Operating limits				
Heating - Indoor air min/max	°C	5/27	5/27	5/27
Heating - Water min/max	°C	10/45	10/45	10/45
Cooling - Indoor air min/max	°C	18/35	18/35	18/35
Cooling - Water min/max	°C	15/50	15/50	15/50

16.2 Operating limits

Limits of operation of the control

	u.d.m.	Heating	Cooling
Minimum room relative humidity	%	15	15
Maximum room relative humidity	%	80	80
Minimum room air temperature	°C	-10	-10
Maximum room air temperature	°C	50	50

16.3 Dimensions

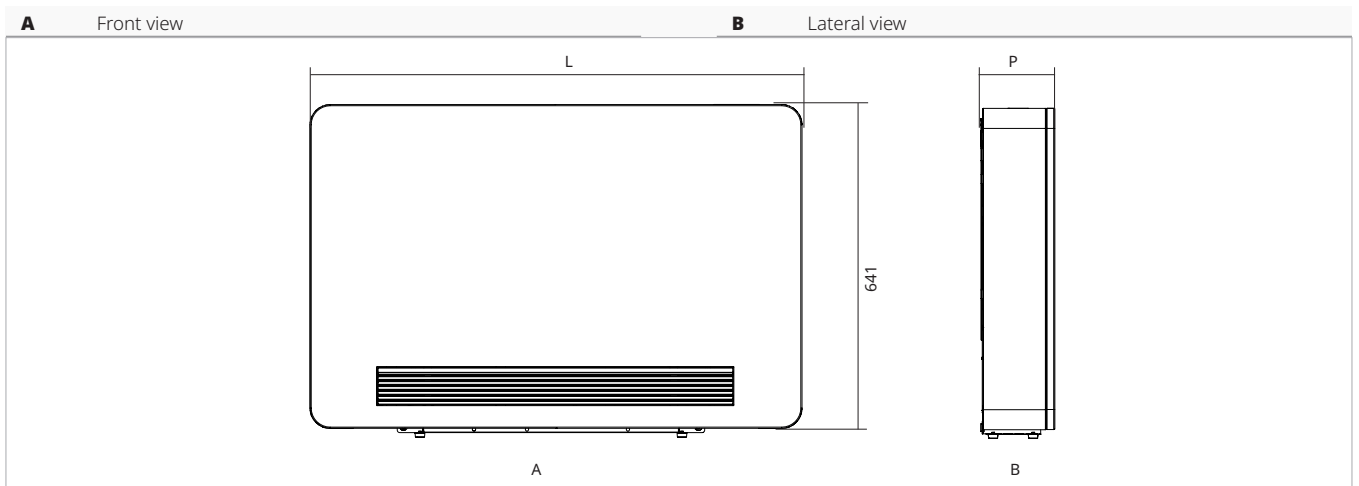

Models	u.m.	10	20	30
Product dimensions and weight				
Width	mm	775	975	1225
Height	mm	641	641	641
Total depth	mm	144	144	144
Empty weight	kg	35,0	40,0	45,0

16.4 Installation template

16.4.1 Model 10 - 20

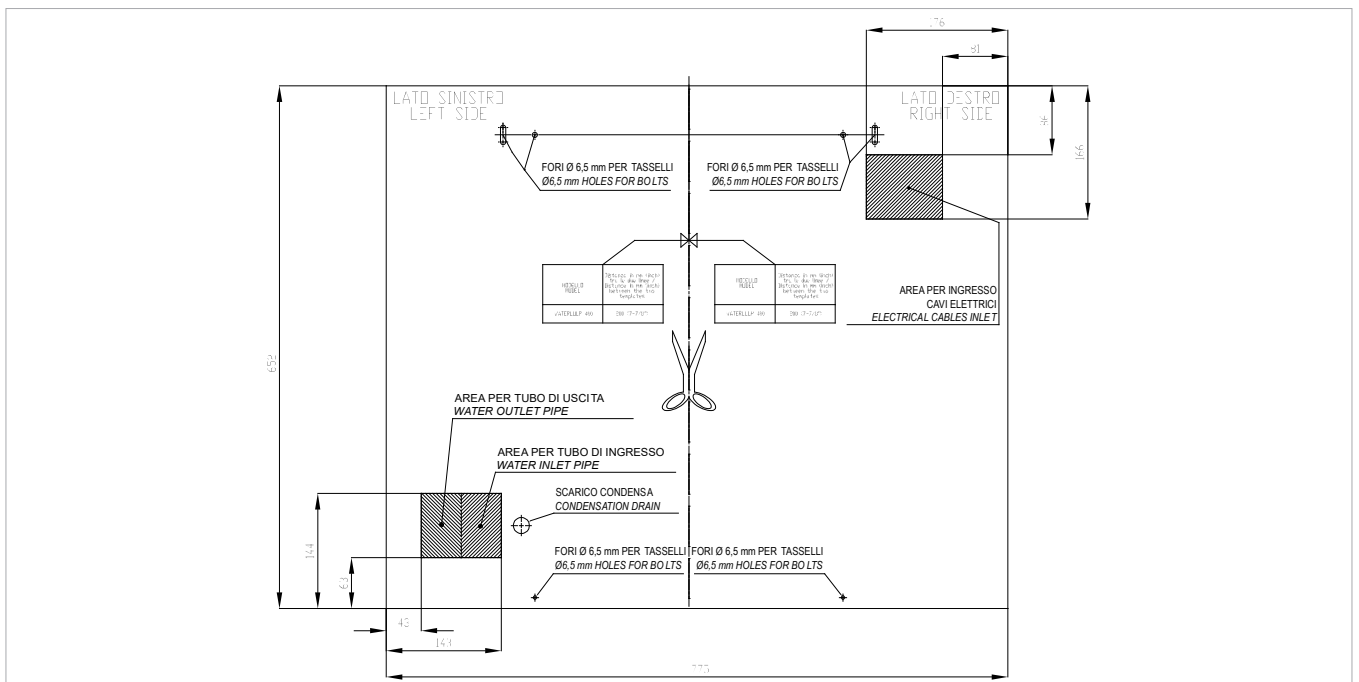

16.5 Information requirements for water/brine-to-air air conditioners

16.5.1 Technical data according to tab. 12 EU Ecodesign Directive 2016/2281

Model 10

Technical data according to tab. 12 EU Ecodesign Directive 2016/2281								
Water-to-air air conditioner								
Model: Information to identify the model to which the information relates:							Aquarea Loop 10	
Indoor side heat exchanger of air conditioner							[default: water/brine]	
Indoor side heat exchanger of air conditioner							[default: air]	
Type: compressor driven vapour compression or sorption process							compression	
If applicable: driver or compressor: [electric motor or fuel driven, gaseous or liquid fuel, internal or external combustion engine]							electric motor	
Item	Symbol	Value	Unit	Item	Symbol	Value	Unit	
Rated cooling capacity	Prated,c	1,1	kW	Seasonal energy efficiency of room cooling	$\eta_{s,c}$	244	%	
Declared cooling capacity for part load at given outdoor temperatures T_j and indoor 27°/19 °C (dry/wet bulb)				Declared energy efficiency ratio or gas utilisation efficiency/auxiliary energy factor for part load at given outdoor temperatures T_j				
External temperature T_j	Cooling tower (inlet/output)	On the ground						
$T_j = +35\text{ °C}$	30/35	10/15	PdC	1,33	kW	$T_j = +35\text{ °C}$	EER_g or $GUE_{c,bin}/AEF_{c,bin}$	4,81
$T_j = +30\text{ °C}$	26/*	10/*	PdC	0,89	kW	$T_j = +30\text{ °C}$	EER_g or $GUE_{c,bin}/AEF_{c,bin}$	5,47
$T_j = +25\text{ °C}$	22/*	10/*	PdC	0,63	kW	$T_j = +25\text{ °C}$	EER_g or $GUE_{c,bin}/AEF_{c,bin}$	7,49
$T_j = +20\text{ °C}$	18/*	10/*	PdC	0,60	kW	$T_j = +20\text{ °C}$	EER_g or $GUE_{c,bin}/AEF_{c,bin}$	8,97
Degradation coefficient for air conditioners (**)			Cdc	0,90	-			
Energy consumption in modes other than "active mode"								
"Off" mode			P_{OFF}		kW	"Crankcase heating" mode	P_{CK}	kW
Thermostat mode off			P_{TO}	0,005	kW	Standby mode	P_{SB}	0,001 kW
Other items								
Capacity control		Variable						
Sound power level, external		L_{WA}	48/-	dB				
If engine driven Emissions of nitrogen oxides (if applicable)		NOX (***)	-	mg/kWh of power supplied by GCV fuel	For water/brine-to-air air conditioners: rated brine or water flow rate, outdoor side heat exchanger	--	0,27	m ³ /h
Refrigerant GWP			0,02	kg CO ₂ eq (100 years)				
Contact information	Panasonic Testing Centre, Panasonic Marketing Europe GmbH Winsbergring 15, 22525 Amburgo, Germania							
(**) If Cdh is not determined by measurement, the default degradation coefficient for heat pumps is 0,25.								
(***) As of 26 September 2018. If the information relates to multi-split air pumps, test results and performance data may be obtained based on the performance of the outdoor unit combined with one or more indoor units as recommended by the manufacturer or importer.								

Model 20

Technical data according to tab. 12 EU Ecodesign Directive 2016/2281								
Water-to-air air conditioner								
Model: Information to identify the model to which the information relates:							Aquarea Loop 20	
Indoor side heat exchanger of air conditioner							[default: water/brine]	
Indoor side heat exchanger of air conditioner							[default: air]	
Type: compressor driven vapour compression or sorption process							compression	
If applicable: driver or compressor: [electric motor or fuel driven, gaseous or liquid fuel, internal or external combustion engine]							electric motor	
Item	Symbol	Value	Unit	Item	Symbol	Value	Unit	
Rated cooling capacity	Prated,c	1,92	kW	Seasonal energy efficiency of room cooling	$\eta_{s,c}$	268	%	
Declared cooling capacity for part load at given outdoor temperatures Tj and indoor 27°/19 °C (dry/wet bulb)				Declared energy efficiency ratio or gas utilisation efficiency/auxiliary energy factor for part load at given outdoor temperatures Tj				
External temperature Tj	Cooling tower (inlet/output)	On the ground						
Tj = +35 °C	30/35	10/15	PdC	2,33	kW	Tj = +35 °C	EER_d or $GUE_{c,bin}/AEF_{c,bin}$	4,66
Tj = +30 °C	26/*	10/*	PdC	1,63	kW	Tj = +30 °C	EER_d or $GUE_{c,bin}/AEF_{c,bin}$	6,95
Tj = +25 °C	22/*	10/*	PdC	1,02	kW	Tj = +25 °C	EER_d or $GUE_{c,bin}/AEF_{c,bin}$	7,48
Tj = +20 °C	18/*	10/*	PdC	0,56	kW	Tj = +20 °C	EER_d or $GUE_{c,bin}/AEF_{c,bin}$	8,06
Degradation coefficient for air conditioners (**)			Cdc	0,90	-			
Energy consumption in modes other than "active mode"								
"Off" mode			P _{OFF}		kW	"Crankase heating" mode	P _{CK}	kW
Thermostat mode off			P _{TO}	0,005	kW	Standby mode	P _{SB}	0,001 kW
Other items								
Capacity control			Variable					
Sound power level, external			L _{WA}	50/-	dB			
If engine driven Emissions of nitrogen oxides (if applicable)			NOX (***)	-	mg/kWh of power supplied by GCV fuel	For water/brine-to-air air conditioners: rated brine or water flow rate, outdoor side heat exchanger	--	0,312 m ³ /h
Refrigerant GWP				0,02	kg CO ₂ eq (100 years)			
Contact information	Panasonic Testing Centre, Panasonic Marketing Europe GmbH Winsbergring 15, 22525 Amburgo, Germania							
(**) If Cdh is not determined by measurement, the default degradation coefficient for heat pumps is 0,25.								
(***) As of 26 September 2018. If the information relates to multi-split air pumps, test results and performance data may be obtained based on the performance of the outdoor unit combined with one or more indoor units as recommended by the manufacturer or importer.								

Model 30

Technical data according to tab. 12 EU Ecodesign Directive 2016/2281	
Water-to-air air conditioner	
Model: Information to identify the model to which the information relates:	Aquarea Loop 30

Indoor side heat exchanger of air conditioner						[default: water/brine]		
Indoor side heat exchanger of air conditioner						[default: air]		
Type: compressor driven vapour compression or sorption process						compression		
If applicable: driver or compressor: [electric motor or fuel driven, gaseous or liquid fuel, internal or external combustion engine]						electric motor		
Item	Symbol	Value	Unit	Item	Symbol	Value	Unit	
Rated cooling capacity	Prated,c	2,7	kW	Seasonal energy efficiency of room cooling	$\eta_{s,c}$	409	%	
Declared cooling capacity for part load at given outdoor temperatures Tj and indoor 27°/19 °C (dry/wet bulb)				Declared energy efficiency ratio or gas utilisation efficiency/auxiliary energy factor for part load at given outdoor temperatures Tj				
External temperature Tj	Cooling tower (inlet/output)	On the ground						
Tj = +35 °C	30/35	10/15	PdC	3,12	kW	Tj = +35 °C	EER _g or GUE _{c,bin} /AEF _{c,bin}	4,60
Tj = +30 °C	26/*	10/*	PdC	2,27	kW	Tj = +30 °C	EER _g or GUE _{c,bin} /AEF _{c,bin}	7,37
Tj = +25 °C	22/*	10/*	PdC	1,37	kW	Tj = +25 °C	EER _g or GUE _{c,bin} /AEF _{c,bin}	13,43
Tj = +20 °C	18/*	10/*	PdC	1,14	kW	Tj = +20 °C	EER _g or GUE _{c,bin} /AEF _{c,bin}	20,45
Degradation coefficient for air conditioners (**)			Cdc	0,90	-			
Energy consumption in modes other than "active mode"								
"Off" mode			P _{OFF}		kW	"Crankcase heating" mode	P _{CK}	kW
Thermostat mode off			P _{TO}	0,005	kW	Standby mode	P _{SB}	0,001 kW
Other items								
Capacity control			Variable					
Sound power level, external			L _{WA}	52/-	dB			
If engine driven Emissions of nitrogen oxides (if applicable)			NOX (***)	-	mg/kWh of power supplied by GCV fuel	For water/brine-to-air air conditioners: rated brine or water flow rate, outdoor side heat exchanger	--	0,54 m ³ /h
Refrigerant GWP				0,02	kg CO ₂ eq (100 years)			
Contact information	Panasonic Testing Centre, Panasonic Marketing Europe GmbH Winsbergring 15, 22525 Amburgo, Germania							
(**) If Cdh is not determined by measurement, the default degradation coefficient for heat pumps is 0,25.								
(***) As of 26 September 2018. If the information relates to multi-split air pumps, test results and performance data may be obtained based on the performance of the outdoor unit combined with one or more indoor units as recommended by the manufacturer or importer.								

16.6 Information requirements for heat pumps

16.6.1 Technical data according to tab. 14 EU Ecodesign Directive 2016/2281

Model 10

Technical data according to tab. 14 EU Ecodesign Directive 2016/2281							
The air/water heat pump							
Model: Information to identify the model to which the information relates:							Aquarea Loop 10
Indoor side heat exchanger of air conditioner							[default: water]
Indoor side heat exchanger of air conditioner							[default: air]
Type: compressor driven vapour compression or sorption process							no
If applicable: driver or compressor: [electric motor or fuel driven, gaseous or liquid fuel, internal or external combustion engine]							electric motor
Parameters shall be declared for the average heating season, parameters for the warmer and colder heating seasons are optional.							
Item	Symbol	Value	Unit	Item	Symbol	Value	Unit
Nominal heating capacity	Prated,h	1,39	kW	Seasonal energy efficiency of space heating	$\eta_{s,H}$	254	%
Declared heating capacity for part load at indoor temperature 20 °C and outdoor temperature Tj				Declared coefficient of performance or gas utilisation efficiency/ auxiliary energy factor for part load at given outdoor temperatures Tj			
Tj = -7 °C	Pdh	1,03	kW	Tj = -7 °C	COP_d or $GUE_{c,bin}/AEF_{c,bin}$	5,68	
Tj = +2 °C	Pdh	0,64	kW	Tj = +2 °C	COP_d or $GUE_{c,bin}/AEF_{c,bin}$	6,85	
Tj = +7 °C	Pdh	0,43	kW	Tj = +7 °C	COP_d or $GUE_{c,bin}/AEF_{c,bin}$	7,00	
Tj = +12 °C	Pdh	0,21	kW	Tj = +12 °C	COP_d or $GUE_{c,bin}/AEF_{c,bin}$	6,28	
T _{biv} = bivalent temperature	Pdh		kW	T _{biv} = bivalent temperature	COP_d or $GUE_{c,bin}/AEF_{c,bin}$		
T _{OL} = operating limit	Pdh		kW	T _{OL} = operating limit	COP_d or $GUE_{c,bin}/AEF_{c,bin}$		
For air-water heat pumps: Tj = - 15 °C (if T _{OL} < - 20 °C)	Pdh		kW	For heat pumps water-to-air: Tj = - 15 °C (se T _{OL} < - 20 °C)	COP_d or $GUE_{c,bin}/AEF_{c,bin}$		
Bivalent temperature	T _{biv}		°C	For heat pumps water/air: operation limit temperature	T _{ol}		°C
Degradation coefficient for air conditioners (**)							
Energy consumption in modes other than "active mode"				Additional heating unit			
"Off" mode	P _{OFF}		kW	Safety heating capacity (*)	ebu		kW
Thermostat mode off	P _{TO}	0,005	kW	Type of energy absorbed			
"carter heating" mode	P _{CK}		kW	Standby mode	P _{SB}	0,001	kW
Other items							
Capacity control		Variable					

Measured sound power level, indoor/ outdoor		L _{WA}	48/-	dB	For air/air heat pumps: air flow, measured outside	--	-	m ³ /h
If engine driven Emissions of nitrogen oxides (if applicable)		NOX (***)	-	mg/kWh of power supplied by GCV fuel	For heat pumps water/air brine: water flow or nom- inal brine, external heat exchanger	--	0,22	m ³ /h
Refrigerant GWP			0,02	kg CO ₂ eq (100 years)				
Contact information	Panasonic Testing Centre, Panasonic Marketing Europe GmbH Winsbergring 15, 22525 Amburgo, Germania							
(*)								
(**) If Cdh is not determined by measurement then the default degradation coefficient of heat pumps shall be 0,25.								
From 26 September 2018. Where information relates to multi-split heat pumps, the test result and performance data may be obtained on the basis of the performance of the outdoor unit, with a combination of indoor unit(s) recommended by the manufacturer or importer.								

Model 20

Technical data according to tab. 14 EU Ecodesign Directive 2016/2281							
The air/water heat pump							
Model: Information to identify the model to which the information relates:							Aquarea Loop 20
Indoor side heat exchanger of air conditioner							[default: water]
Indoor side heat exchanger of air conditioner							[default: air]
Type: compressor driven vapour compression or sorption process							no
If applicable: driver or compressor: [electric motor or fuel driven, gaseous or liquid fuel, internal or external combustion engine]							electric motor
Parameters shall be declared for the average heating season, parameters for the warmer and colder heating seasons are optional.							
Item	Symbol	Value	Unit	Item	Symbol	Value	Unit
Nominal heating capacity	Prated,h	2,14	kW	Seasonal energy efficiency of space heating	$\eta_{s,H}$	272	%
Declared heating capacity for part load at indoor temperature 20 °C and outdoor temperature Tj				Declared coefficient of performance or gas utilisation efficiency/ auxiliary energy factor for part load at given outdoor temperatures Tj			
Tj = -7 °C	Pdh	1,56	kW	Tj = -7 °C	COP_d or $GUE_{c,bin}^d / AEF_{c,bin}$	6,03	
Tj = +2 °C	Pdh	0,99	kW	Tj = +2 °C	COP_d or $GUE_{c,bin}^d / AEF_{c,bin}$	8,20	
Tj = +7 °C	Pdh	0,65	kW	Tj = +7 °C	COP_d or $GUE_{c,bin}^d / AEF_{c,bin}$	8,29	
Tj = +12 °C	Pdh	0,61	kW	Tj = +12 °C	COP_d or $GUE_{c,bin}^d / AEF_{c,bin}$	8,29	
T _{biv} = bivalent temperature	Pdh		kW	T _{biv} = bivalent temperature	COP_d or $GUE_{c,bin}^d / AEF_{c,bin}$		
T _{OL} = operating limit	Pdh		kW	T _{OL} = operating limit	COP_d or $GUE_{c,bin}^d / AEF_{c,bin}$		
For air-water heat pumps: Tj = - 15 °C (if T _{OL} < - 20 °C)	Pdh		kW	For heat pumps water-to-air: Tj = - 15 °C (se T _{OL} < - 20 °C)	COP_d or $GUE_{c,bin}^d / AEF_{c,bin}$		
Bivalent temperature	T _{biv}		°C	For water-to-air heat pumps: Operation limit temperature	T _{ol}		°C
Degradation coefficient for air conditioners (**)				Cdc	0,90	-	
Energy consumption in modes other than "active mode"				Additional heating unit			
"Off" mode	P _{OFF}		kW	Safety heating capacity (*)	ebu		kW
Thermostat mode off	P _{TO}	0,005	kW	Type of energy absorbed			
"carter heating" mode	P _{CK}		kW	Standby mode	P _{SB}	0,001	kW
Other items							
Capacity control		Variable					
Measured sound power level, indoor/ outdoor	L _{WA}	50/-	dB	For air/air heat pumps: air flow, measured outside	--	-	m ³ /h

If engine driven Emissions of nitrogen oxides (if applicable)		NOX (***)	-	mg/kWh of power supplied by GCV fuel	For heat pumps water/air brine: water flow or nominal brine, external heat exchanger	--	0,462	m ³ /h
Refrigerant GWP			0,02	kg CO ₂ eq (100 years)				
Contact information	Panasonic Testing Centre, Panasonic Marketing Europe GmbH Winsbergring 15, 22525 Amburgo, Germania							
(*)								
(**) If Cdh is not determined by measurement then the default degradation coefficient of heat pumps shall be 0,25.								
From 26 September 2018. Where information relates to multi-split heat pumps, the test result and performance data may be obtained on the basis of the performance of the outdoor unit, with a combination of indoor unit(s) recommended by the manufacturer or importer.								

Model 30

Technical data according to tab. 14 EU Ecodesign Directive 2016/2281							
The air/water heat pump							
Model: Information to identify the model to which the information relates:							Aquarea Loop 30
Indoor side heat exchanger of air conditioner							[default: water]
Indoor side heat exchanger of air conditioner							[default: air]
Type: compressor driven vapour compression or sorption process							no
If applicable: driver or compressor: [electric motor or fuel driven, gaseous or liquid fuel, internal or external combustion engine]							electric motor
Parameters shall be declared for the average heating season, parameters for the warmer and colder heating seasons are optional.							
Item	Symbol	Value	Unit	Item	Symbol	Value	Unit
Nominal heating capacity	Prated,h	3,05	kW	Seasonal energy efficiency of space heating	$\eta_{s,H}$	254	%
Declared heating capacity for part load at indoor temperature 20 °C and outdoor temperature Tj				Declared coefficient of performance or gas utilisation efficiency/ auxiliary energy factor for part load at given outdoor temperatures Tj			
Tj = -7 °C	Pdh	2,73	kW	Tj = -7 °C	COP_d or $GUE_{c,bin} / AEF_{c,bin}$	5,66	
Tj = +2 °C	Pdh	1,43	kW	Tj = +2 °C	COP_d or $GUE_{c,bin} / AEF_{c,bin}$	6,97	
Tj = +7 °C	Pdh	0,89	kW	Tj = +7 °C	COP_d or $GUE_{c,bin} / AEF_{c,bin}$	8,38	
Tj = +12 °C	Pdh	0,89	kW	Tj = +12 °C	COP_d or $GUE_{c,bin} / AEF_{c,bin}$	8,38	
T _{biv} = bivalent temperature	Pdh		kW	T _{biv} = bivalent temperature	COP_d or $GUE_{c,bin} / AEF_{c,bin}$		
T _{ol} = operating limit	Pdh		kW	T _{ol} = operating limit	COP_d or $GUE_{c,bin} / AEF_{c,bin}$		
For air-water heat pumps: Tj = - 15 °C (if T _{ol} < - 20 °C)	Pdh		kW	For heat pumps water-to-air: Tj = - 15 °C (se T _{ol} < - 20 °C)	COP_d or $GUE_{c,bin} / AEF_{c,bin}$		
Bivalent temperature	T _{biv}		°C	For water-to-air heat pumps: Operation limit temperature	T _{ol}		°C
Degradation coefficient for air conditioners (**)							
Energy consumption in modes other than "active mode"				Additional heating unit			
"Off" mode	P _{OFF}		kW	Safety heating capacity (*)	ebu		kW
Thermostat mode off	P _{TO}	0,005	kW	Type of energy absorbed			
"carter heating" mode	P _{CK}		kW	Standby mode	P _{SB}	0,001	kW
Other items							
Capacity control		Variable					
Measured sound power level, indoor/ outdoor	L _{WA}	52/-	dB	For air/air heat pumps: air flow, measured outside	--	-	m ³ /h

If engine driven Emissions of nitrogen oxides (if applicable)		NOX (***)	-	mg/ kWh of power sup- plied by GCV fuel	For heat pumps water/air brine: water flow or nom- inal brine, external heat exchanger	--	0,72	m ³ /h
Refrigerant GWP			0,02	kg CO ₂ eq (100 years)				
Contact information	Panasonic Testing Centre, Panasonic Marketing Europe GmbH Winsbergring 15, 22525 Amburgo, Germania							
(*)								
(**) If Cdh is not determined by measurement then the default degradation coefficient of heat pumps shall be 0,25.								
From 26 September 2018. Where information relates to multi-split heat pumps, the test result and performance data may be obtained on the basis of the performance of the outdoor unit, with a combination of indoor unit(s) recommended by the manufacturer or importer.								

Panasonic[®]

Panasonic Corporation
1006 Kadoma, Kadoma City, Osaka, Japan