

Control Installation Manual
(original instructions)

EN

Panasonic[®]

N421119A - Rev.03 - 07-2025

Aquarea Air - Floor Standing

P-FAL** series

First of all, we would like to thank you for having chosen a device of our production.

We are sure you will be happy with it because it represents the state of the art in the technology of home air conditioning.

By following the suggestions contained in this manual, the product you have purchased will provide trouble free operation, giving you optimum room temperatures with minimum energy costs.

Panasonic Corporation

Conformity

Refer to the Installation Manual of the paired unit.

Markings



TABLE OF CONTENTS

1. Coding	4	8. Wall-mounted control Cod. PCZ-EFB749	37
1.1 Coding accessories	4	8.1 Interface	37
2. General information	5	8.2 Installation	37
2.1 About the manual	5	8.3 Single connection diagram	39
2.2 General warnings	6	8.4 Multiple connection diagram	40
2.3 Basic rules of security	6	8.5 Connections	41
2.4 Disposal	7	8.6 Functions	42
3. Preparation for touchpad connection	8	9. Connection 0-10 V Code PCZ-B10842	47
3.1 Preliminary warnings	8	9.1 Installation	47
3.2 Preparation for command connection	8	9.2 Connection diagram	47
4. Touchpad cod. PCZ-ECA844	13	9.3 Connections with 0-10 V thermostats	48
4.1 Interface	13	9.4 LED signal	48
4.2 Description	13	10. Technical information	49
4.3 PCB	14	10.1 Operating limits	49
4.4 Connections	15		
4.5 Functions	15		
5. Touchpad coding PCZ-EWA844	18		
5.1 Interface	18		
5.2 Description	18		
5.3 PCB	19		
5.4 Connections	20		
5.5 Functions	20		
6. Preparation for connecting wall controls	23		
6.1 Preliminary warnings	23		
6.2 Preparation for command connection	23		
7. Wall-mounted control Cod. PCZ-EEB749	27		
7.1 Interface	27		
7.2 Installation	27		
7.3 Single connection diagram	29		
7.4 Multiple connection diagram	30		
7.5 Connections	31		
7.6 Functions	32		





1. CODING

⚠ The present manual refers to the products:

- Aquarea Air - Floor Standing

1.1 Coding accessories





This instruction manual refers to the following accessory codes.

	Accessory description	Code
Controls on the device		
	On-board control, with continuously modulating thermostat.	PCZ-ECA844
	On-board control, with continuously modulating thermostat, with integrated Wi-Fi module.	PCZ-EWA844
Wall-mounted control panels		
PCB		
	Electronic board on board unit with continuous modulation. For connection to wall-mounted control.	PCZ-ESE845
Control panels		
	LED electronic control panel with touch interface, wall mounted complete with thermostat and room temperature and relative humidity probe. Cable connection. White colour	PCZ-EEB749
	LED electronic control panel with touch interface, wall-mounted complete with thermostat and room temperature and relative humidity probe with integrated Wi-Fi module. Cable connection. White colour	PCZ-EFB749
Standard wall mounted controls		
PCB		
	On-board electronic printed circuit board for control from systems with 0-10 V analogue output.	PCZ-B10842

2. GENERAL INFORMATION

2.1 About the manual





This manual was written to provide all the explanations for the correct management of the device.

-  This instruction manual forms an integral part of the device and therefore must be carefully preserved and must ALWAYS travel with it, even if you transfer the device to another owner or relocate it to other premises. If the manual gets damaged or lost, download a copy from the website.
-  Read this manual carefully before proceeding with any operation and follow the instructions in the individual chapters.
-  The Manufacturer accepts no liability for damages to persons or property caused by failure to follow the instructions in this manual.
-  This document is restricted in use to the terms of the law and may not be copied or transferred to third parties without the express authorisation of the Manufacturer.

2.1.1 Editorial pictograms

The pictograms in the next chapter provide the necessary information for correct and safe use of the machine in a rapid and unmistakable way.

Related to security

-  **High risk warning (bold text)**
 - The operation described above presents a risk of serious physical injury, fatality, major damage to the device and/or to the environment if not carried out in compliance with safety regulations.
-  Low risk warning (plain text)
 - The operation described above presents a risk of minor physical injury or minor damage to the device and/or to the environment if not carried out in compliance with safety regulations.
-  Prohibition (plain text)
 - Refers to prohibited actions.
-  **Important information (bold text)**
 - This indicates important information that must be taken into account during the operations.



In the texts

- ▶ procedures
- lists

In the control panels

- ▶ actions required
- Expected responses following an action.*

In the figures

- 1 The numbers indicate the individual components.
- A The capital letters indicate component assemblies.
-  The white numbers in black marks indicate a series of actions to be carried out in sequence.
-  The black letter in white identifies an image when there are several images in the same figure.

2.1.2 Pictograms on the product

Symbols are used in some parts of the device:

Related to security



Read instruction manual

Read the instructions carefully before performing any work on the device.



Instruction manual

Read the information available in the technical documentation of the device.



Caution: electrical danger

- The concerned personnel is informed to the presence of electricity and the risk of suffering an electric shock.

2.1.3 Recipients

User

Non-expert person capable of operating the product in safe conditions for people, for the product itself and the environment, interpreting an elementary diagnostic of faults and abnormal operating conditions, carrying out simple adjustment, checking and maintenance operations.

Installer

Expert person qualified to position and connect (hydraulically, electrically, etc.) the unit to the plant; this person is responsible for handling and correct installation according to the instructions provided in this manual and the national standards currently in force.

Authorized Service Center

Expert and qualified person authorised directly by the manufacturer to carry out all routine and supplementary maintenance operations, as well as every adjustment, check, repair and replacement of parts necessary during the life of the unit itself.

2.1.4 Manual organization

The manual is divided into sections each dedicated to one or more target groups.

Coding

It addresses all recipients.
It contains the list of products and/or accessories referred to in the manual.

General information

It addresses all recipients.
It contains general information and important warnings that should be known before installing and using the device.

Installation

It is addressed exclusively to the installer.

It contains specific warnings and all the information necessary for positioning, mounting and connecting the appliance.

Control panels

It is addressed only and exclusively to the Installer and the Authorised Service Centre.
These are sections dedicated to the different types of controls and electronic boards combined with the range with specific information for that combination.

Technical information

It addresses all recipients.
It contains detailed technical information about the appliance.

2.2 General warnings

- ⚠ Specific warnings are given in each chapter of the document and must be read before starting operations.
- ⚠ All personnel involved must be aware of the operations and dangers that may arise when beginning all unit installation operations.
- ⚠ Installation performed outside the warnings provided in this manual and use of the appliance outside the prescribed temperature limits will invalidate the warranty.
- ⚠ The installation and maintenance of climate control equipment can be dangerous due to live electrical components inside the appliances. The installation, initial start-up and subsequent maintenance phases must be carried out exclusively by authorized and qualified personnel (see first start-up request form enclosed with the appliance).
- ⚠ Any contractual or extra-contractual liability for damage caused to persons, animals or property, due to installation adjustment and maintenance errors, or improper use, is excluded. All uses not expressly indicated in this manual are not permitted.
- ⚠ Only suitably qualified installers are authorized to install the device. After having completed installation, the installer will issue a declaration of conformity to the plant manager, as required by the applicable standards and the guidelines provided by contractor's instruction manual supplied with the device.
- ⚠ First start-up and repair or maintenance operations must be carried out by the Technical Assistance Center or by qualified personnel following the provisions of this manual.

- ⚠ Do not modify or tamper with the appliance as this can lead to dangerous situations.
- ⚠ Use suitable personal protective clothing and equipment during installation and/or maintenance operations. The Manufacturer is not liable for the non-observance of the current safety and accident prevention regulations.
- ⚠ In the event of liquid or oil leaks, set the main switch of the plant to "OFF" and isolate water taps where applicable. Call the Authorized Service Center or professionally qualified personnel as soon as possible and do not work on the appliance yourself.
- ⚠ In case of replacement of parts, use only original parts.
- ⚠ The Manufacturer reserves the right to make changes to its models at any time to improve its product, without prejudice to the essential characteristics described in this manual. The manufacturer is not obliged to add such modifications to machines previously manufactured, already delivered or under construction.
- ⚠ The unit can be used by children over the age of 8, and by people with reduced physical, sensory or mental capabilities, or with no experience or necessary knowledge, as long as they are monitored or after they have received instructions on the safe use of the unit and have understood the dangers involved. Children must not play with the appliance. The cleaning and maintenance that must be performed by the user should not be carried out by children without supervision.

2.3 Basic rules of security

Please keep in mind that the use of products powered by electricity and water call for operators to comply with certain essential safety rules:

- ⊖ It is forbidden to touch the device with wet or damp body parts.
- ⊖ It is forbidden to carry out any operation before disconnecting the appliance from the power supply by setting the plant main switch to "OFF".

- ⊖ It is forbidden to modify the safety or adjustment devices, or adjust without authorization and indications of the Manufacturer.
- ⊖ It is forbidden to pull, unplug or twist the device's electric cables, even if it is disconnected from the mains.
- ⊖ It is forbidden to introduce objects and substances through the air inlet and outlet grilles.

- ⊖ It is forbidden to open the access doors of the device's internal parts without first having set main switch of the system to "OFF".
- ⊖ It is forbidden to incorrectly dispose of the packaging, or leave in the reach of children, which may become a source of danger.

2.4 Disposal



The symbol on the product or packaging indicates that the product must not be treated as normal household waste, but must be taken to the appropriate collection point for recycling of used electrical and electronic equipment and batteries.

Proper disposal of this product avoids harm to humans and the environment and promotes the reuse of valuable raw materials.

For more detailed information about the recycling of this product, contact your local authority, your household waste disposal service or the shop where you purchased the product.

Illegal disposal of the product by the user involves the application of the administrative sanctions provided for by the regulations in force.

This provision is valid in the EU Member States.

3. PREPARATION FOR TOUCHPAD CONNECTION

3.1 Preliminary warnings

⚠ The following procedure is required to connect the touchpad (PCZ-ECA844 - PCZ-EWA844).

3.2 Preparation for command connection

3.2.1 Accompanying material

Accompanying the unit, contained in a bag placed on the cover of the electrical box, are:

- 1 terminal for power supply connection (230V~50Hz)
- cable gland
- 1 terminal for serial connection (-BA+)
- screws

3.2.2 Preliminary warnings

- ⚠ Before carrying out any work, please ensure the power supply is disconnected.
- ⚠ All operations of an electrical nature must be carried out by qualified personnel having the necessary training, who understands the training, who understands the legal requirements, and is informed about the risks related to such operations.
- ⚠ All connections must be made following the regulations in force in the country of installation.
- ⚠ The unit must only be powered after work has been completed.
- ⚠ Isolate and lock off the main circuit breaker before making any electrical connections and performing any type of operation.
- ⚠ Access to the electrical panel is only permitted to qualified personnel.
- ⚠ Refer to the respective section of the control, used to make the electrical connections.

3.2.3 Device preparation

Before proceeding with the installation, it is necessary to remove some elements from the appliance.

1. Fixing screws
2. Upper grille

3. Aesthetic side panels

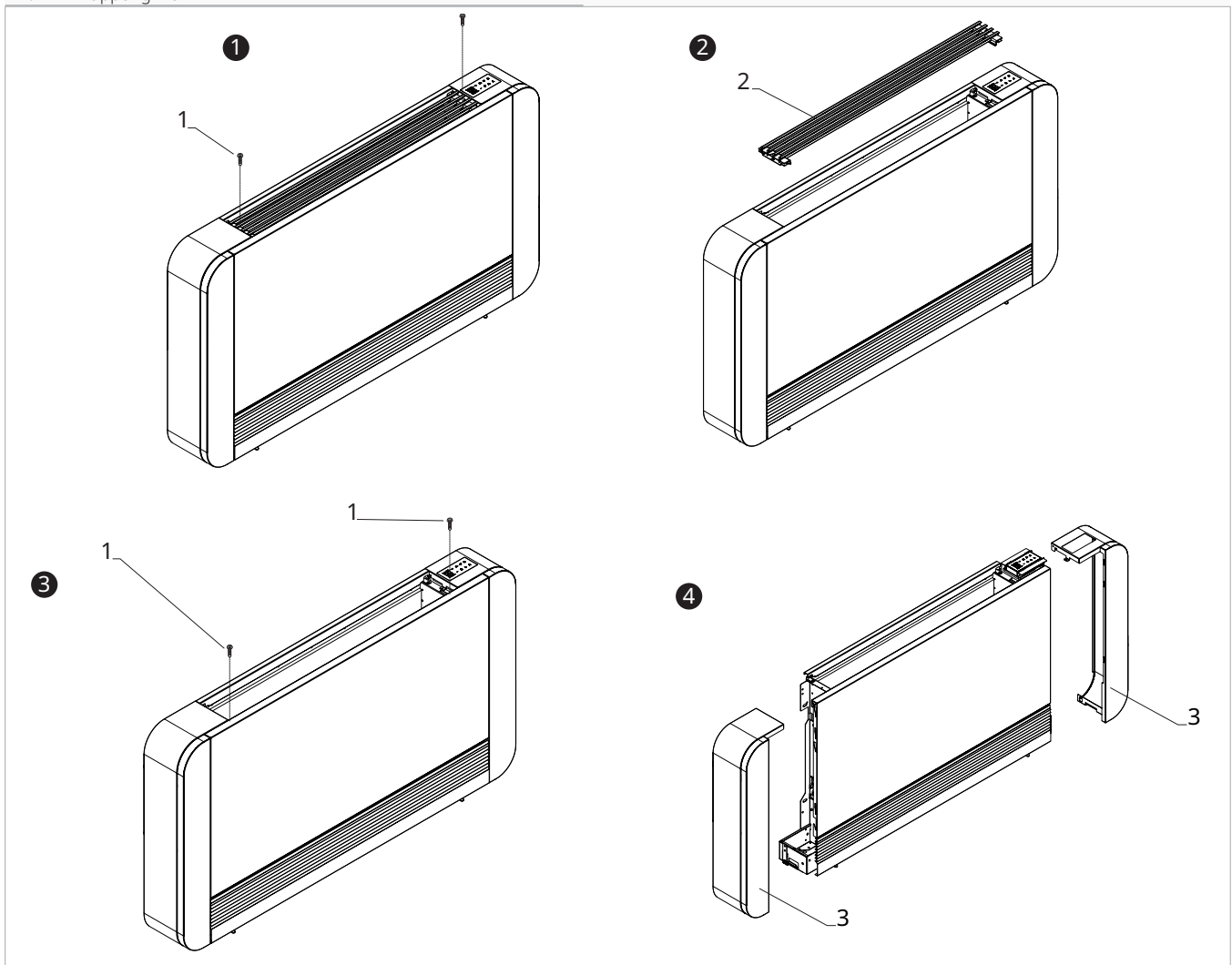

To remove the grille:

- ▶ remove the fixing screws
- ▶ lift up and remove the upper grille

To remove the aesthetic side panels:

- ▶ remove the fixing screws
- ▶ slightly move the side panel outwards
- ▶ lift and remove the side panel

3.2.4 Installation of electrical connection box

- ⚠ Normally the unit leaves the factory with the electrical box mounted.
- ⚠ In exceptional cases, the electrical box can be installed at a later stage.

3. PREPARATION FOR TOUCHPAD CONNECTION

1. Electrical back box
2. Notches
3. Holes

4. Fixing screws
5. Cable strain relief clamp
6. Fixing of ground cable

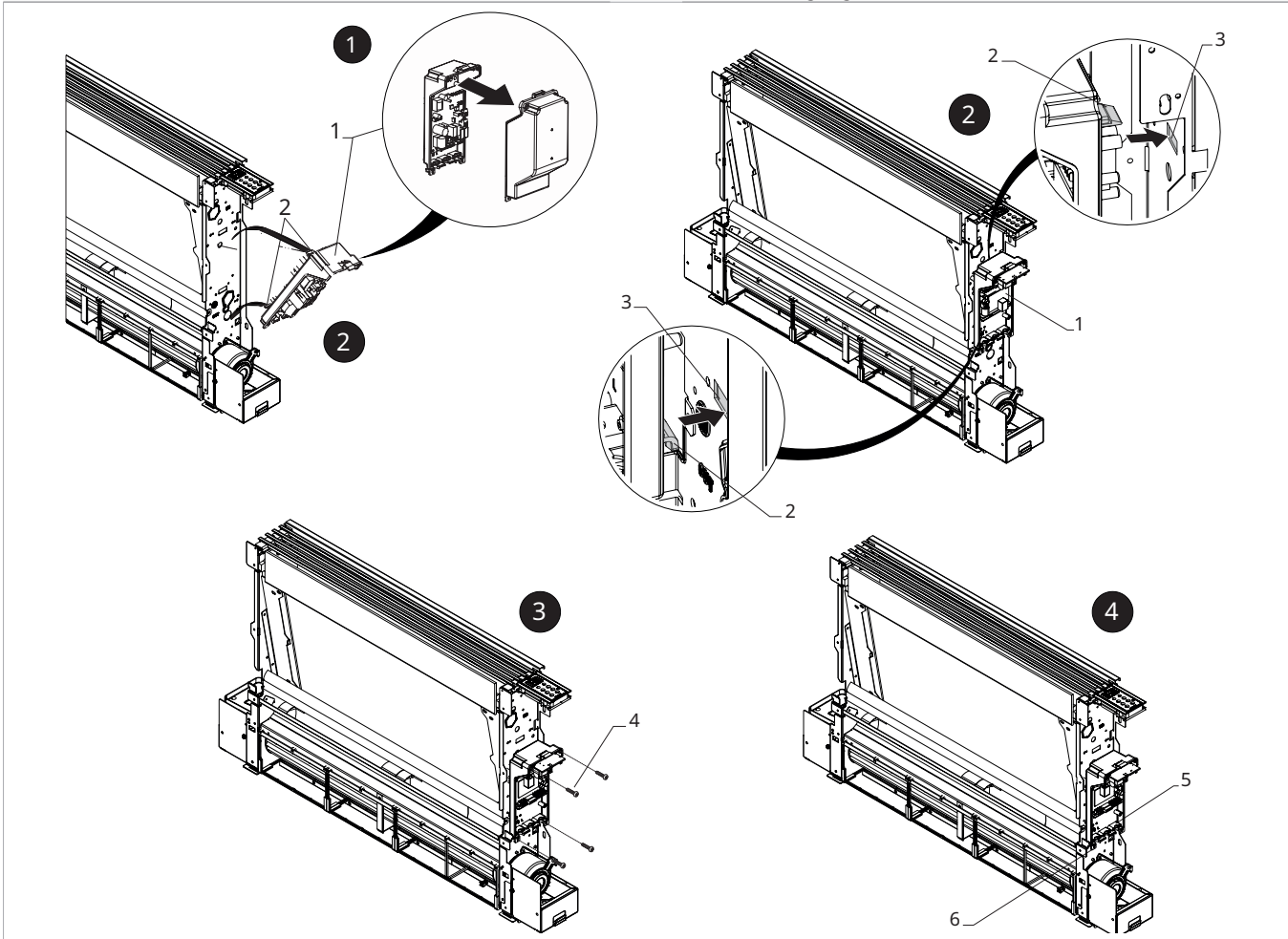

To install the electrical box:

- ▶ open the electrical box
- ▶ place the base of the electrical box on the side of the appliance
- ▶ Wedge the notches of the electrical box into the appropriate holes on the side of the appliance
- ▶ secure the electrical box with the fixing screws provided
- ▶ secure the ground cable to the structure of the appliance with the screw provided

⚠ The minimum force that must be exerted for starting is approximately 2 N.

- ▶ connect the connector to the MOTOR quick connector on the printed circuit board
- ▶ connect the water probe to the T2 connector on the device

⚠ The water temperature probe monitors the temperature inside the coils and determines fan start-up according to preset parameters. (winter minimum and summer maximum functions)

⚠ Check that the probe is correctly positioned in the compartment on the coil.

- ▶ connect the electrical wiring
- ▶ tidy up the cables
- ▶ secure the cables using the grommets provided
- ▶ close the electrical box

▶ secure the electrical box with the fixing screws provided

3.2.5 Completed assembly

- | | |
|----|-----------------------------|
| 1. | Fixing screws |
| 2. | Cover of the electrical box |
| 3. | Terminal block for wiring |

- | | |
|----|-----------------------|
| 4. | Aesthetic side panels |
| 5. | Upper grille |

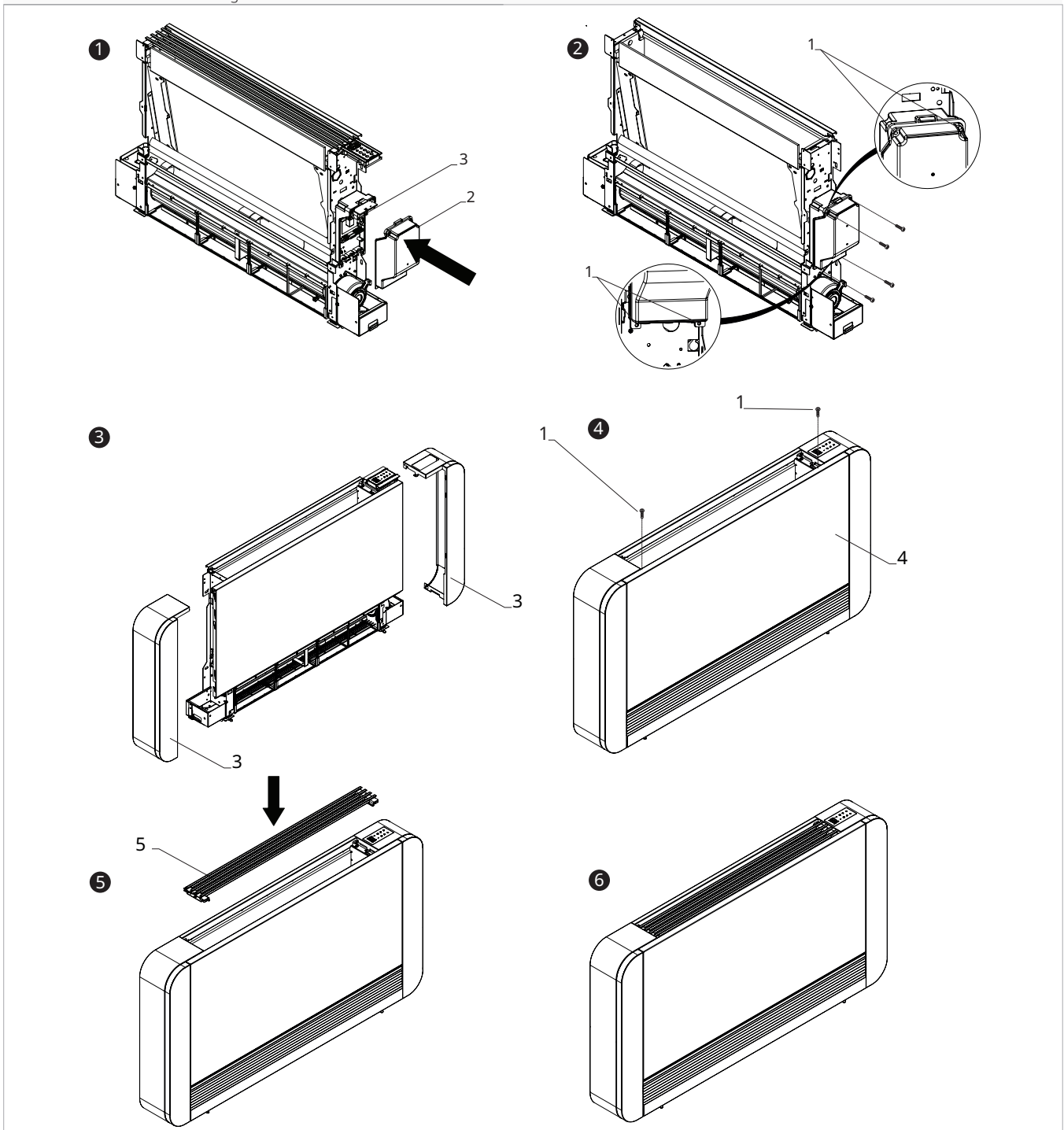

Completed assembly

- ▶ place the cover of the electrical box
- ▶ fix with screws
- ▶ reassemble the aesthetic side panel
- ▶ fix with screws
- ▶ replace the upper grille
- ▶ fix with screws

3.2.6 Access to the terminal block

- 1. Fixing screws
- 2. Cover of the electrical box

- 3. Terminal block for wiring

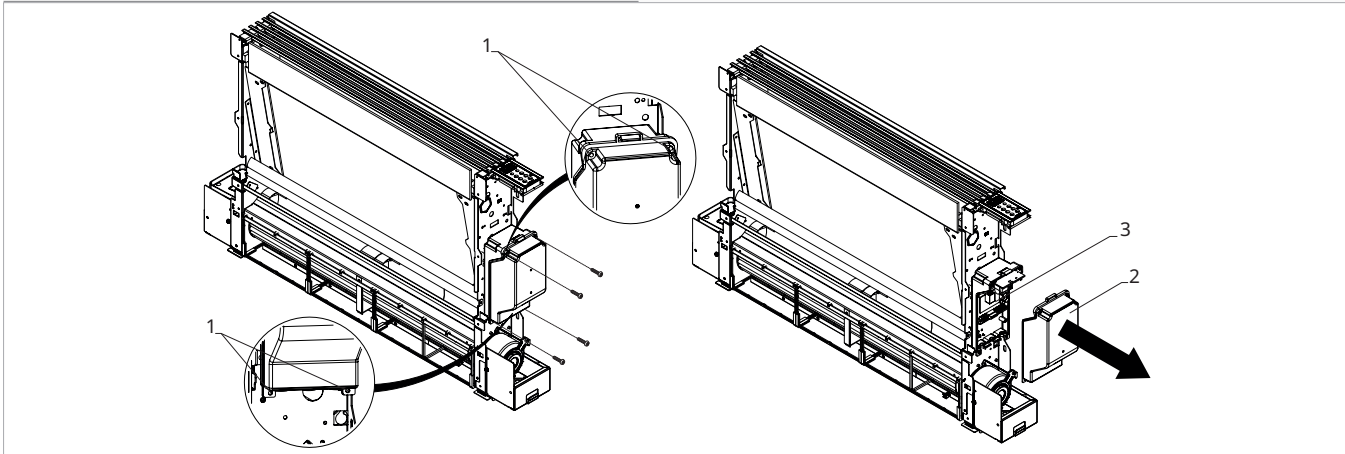

⚠ Before carrying out any work, please ensure the power supply is disconnected.

To access:

- ▶ if installed, remove the movable cover panel

To access the connections:

- ▶ unscrew the fixing screws of the electric box
- ▶ remove the lid from the junction box

⚠ It is necessary to check that the power supply is provided with appropriate protection against electrical shorts and/or overloads

- 1. Terminal block for wiring
- 2. Power supply cables
- 3. Quick-connect terminal
- 4. Earth connection

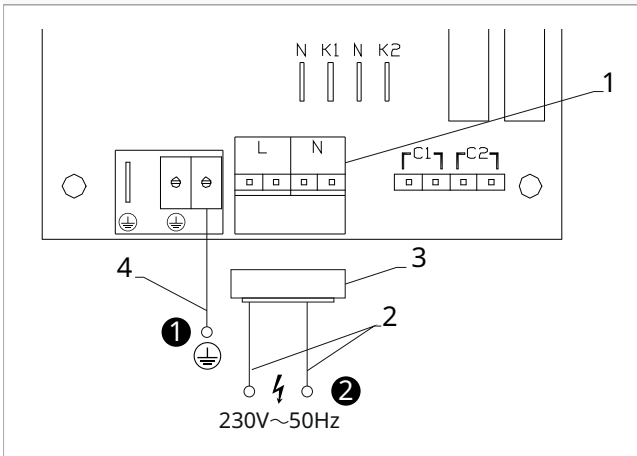

To make the connections:

- ▶ use the supplied quick terminal
- ▶ connect phase and neutral (230 V~50 Hz) to the quick terminal
- ▶ connect the quick-connect terminal to the terminal block
- ▶ Connect the earthing wire (⊕) to the terminal provided on the electrical panel

⚠ Refer to the information in the wiring diagram of the unit you are installing.

⚠ Please refer to the sections of the respective controls for indications of electrical connections.

⚠ The electrical connection can be made by a cable recessed into the wall as indicated on the installation template (connection recommended for installation of the device at the top of the wall).

4. TOUCHPAD COD. PCZ-ECA844

4.1 Interface

The touchpad control is supplied as standard on board the unit, does not require any connections and enables:

- show the operating status

- show any alarms
- select the various functions

1. Display area
2. Keys area

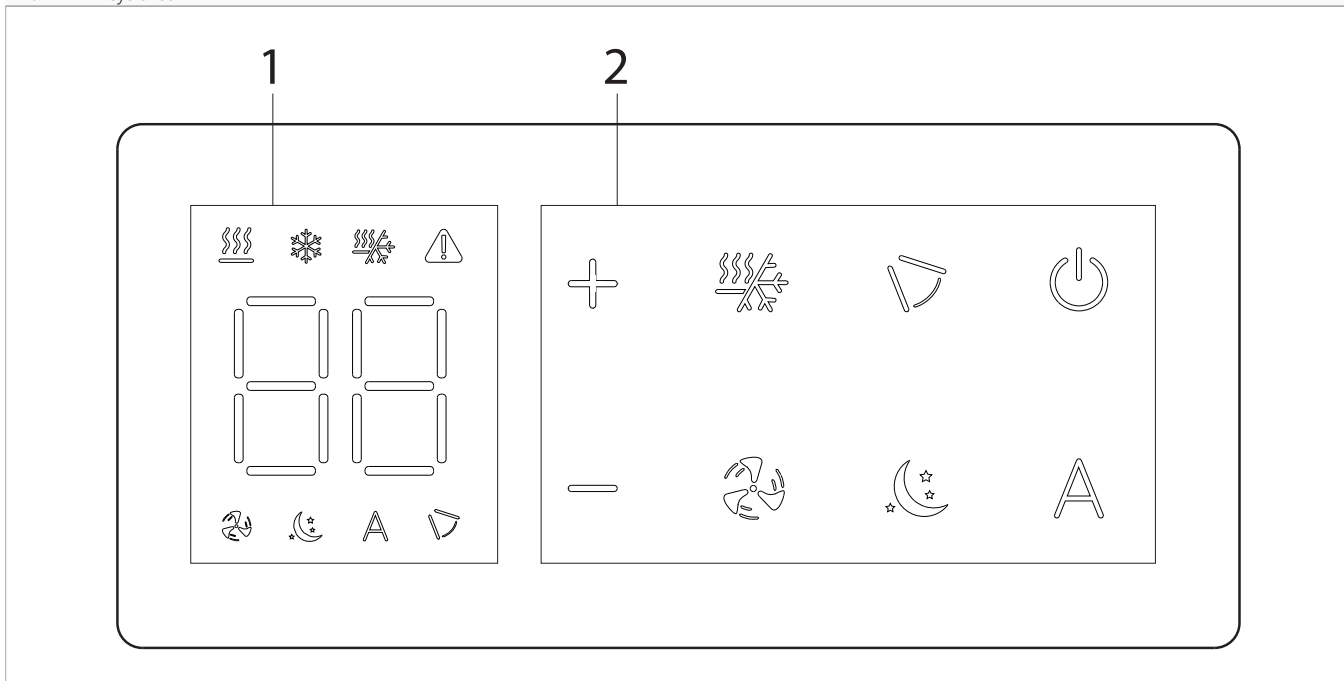

4.2 Description

On-board control, with continuously modulating thermostat.

4.3 PCB

The PCB is included in the supply.

M1	DC fan motor
	Ground connection
230~50	Power supply connection 230 V / 50 Hz / 1 A
Y1	Water solenoid valve
CH/C1	Cooling request contact (for example chiller or reversible heat pump). Activated in parallel with the solenoid valve output (Y1) with 1 minute delay when the fancoil is in cooling mode and is on call (potential-free contact max. 1 A).
BO/C2	Heating request contact (for example boiler or heat pump). Activated in parallel with the output of the solenoid valve (Y1)

CP	Presence contact (normally open)
IN1	Input for potential-free contact 1
AIR/T1	Air temperature probe
H2/T2	Water temperature probe
DU	Touchpad
PU	Electronic board on the unit

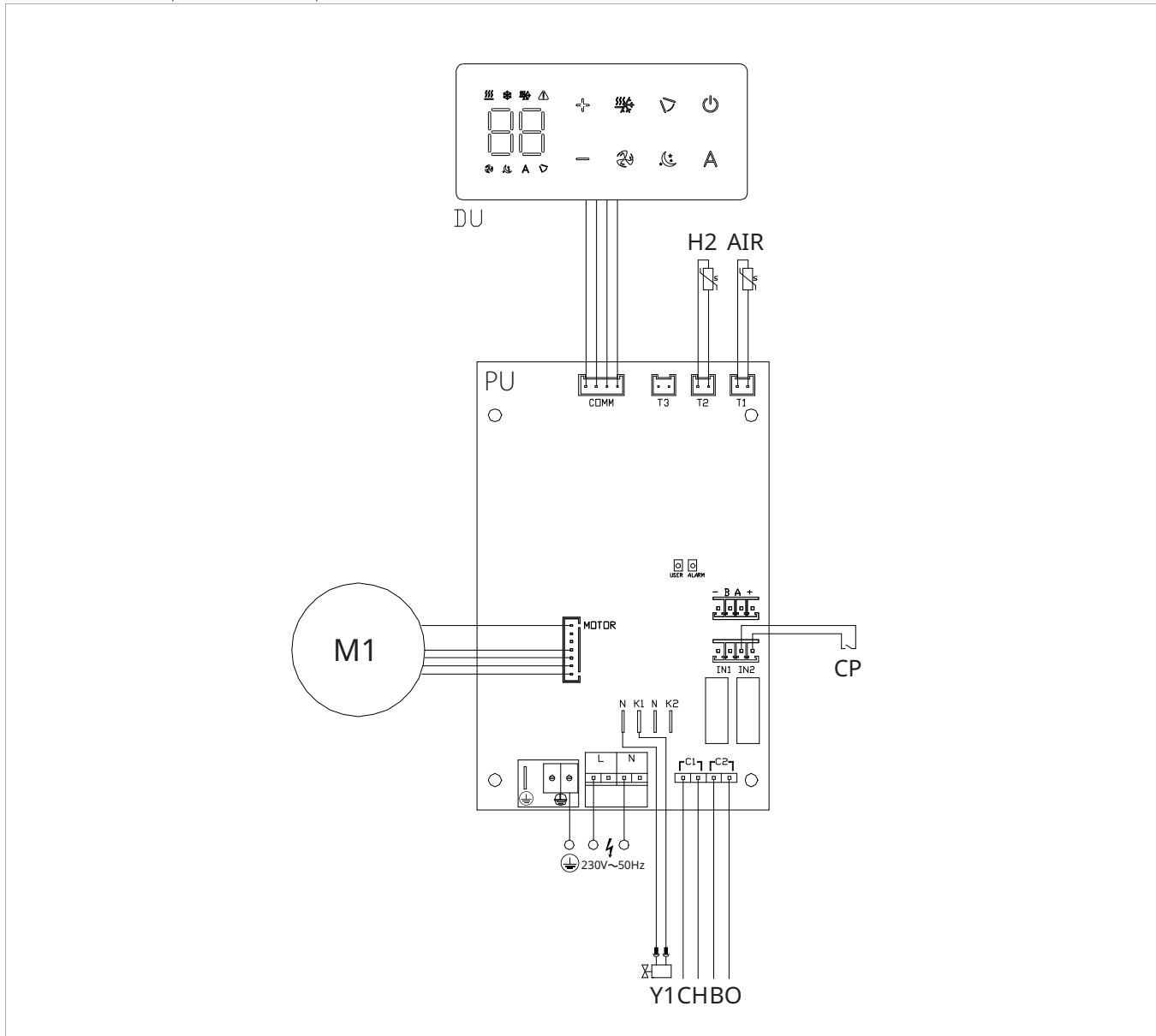

Through the water temperature probe H2/T2 (10 kΩ) located in the thermowell on the unit's coil, the temperature setpoints for fan stop are controlled:

- minimum temperature in heating mode (30 °C)
- maximum temperature in cooling mode (20 °C)

⚠ The printed circuit board provides for operation without a water probe. In this case, the fan stop thresholds are ignored.

4.4 Connections

4.4.1 Presence contact CP

Through this device it is possible to connect an external control signal that inhibits the operation of the control signal, for example:

- opening window contact
- remote on/off
- infrared presence sensor
- activation badge

Function

The contact is normally open (NO).





- ▶ when closing the CP contact, connected to a potential-free contact, the device switches to stand-by mode
- ▶ At the touch of a button on the display the symbol  flashes.

⊖ It is forbidden to connect the CP input to that of another unit electronic board. Use separate contacts. The CP presence contact can be configured for heating and cooling operation via the "To select digital input" *p. 16* settings menu item (digital input).



4.5 Functions

4.5.1 Basic menu

To access the basic menu

- ▶ with the display off, hold down  for 10 seconds
The device turns on and  appears
- ▶ keep pressed until the indication  appears
- ▶ release the  key
The symbol  appears

To navigate in the menu

- ▶ use the icons  

To select a menu item and to confirm the changes made

- ▶ press the icon 
Confirming the change takes you to the next item.

To exit the menu

- ▶ press the icon  for 10 seconds
- ▶ or wait 30 seconds after the last action
The display is switched off automatically.

Menu items

ot: AIR probe offset (air probe setting)

CF: Scale



ub: Buzzer volume

uu: Not used





up: Not used

ho: Hotel Mode

Set AIR probe offset



 The set value changes by 1 °C each press of the  and  buttons.

To set the air probe offset

- ▶ select 
- ▶ press  to change settings
- ▶ increase or decrease the value with the icons  
- ▶ press  to confirm
*By default it is set to 0.
The range of settings is from a minimum of -9°C to a maximum of +9°C.*





Scale

To change the temperature unit of measure

- ▶ select 
- ▶ press  to change settings
- ▶ select °C or °F
- ▶ press  to confirm
By default the temperature unit of measure is °C.

Adjusting buzzer volume

To change the volume

- ▶ select 
- ▶ press  to change settings
- ▶ increase or decrease the value with the icons  
- ▶ press  to confirm
The volume setting range is from 00 (min) to 03 (max).

 The volume changes after confirming the modification.

Setting the Hotel Mode

To set the Hotel mode

- ▶ select 
 - ▶ select YS to turn on Hotel mode
 - ▶ select NO to turn off the Hotel mode
- By default the device is set to NO.*

Activating the Hotel mode:

- the Autochangeover function is deactivated
- the temperature setting range is reduced, in Cooling you can set from 22 °C to 28 °C, in Heating you can set from 16 °C to 24 °C



4.5.2 Advanced Menu



⚠ To access the setup menu, it is necessary to access the Basic menu. See section "Basic menu" p. 15.

The special functions menu can be accessed via the control panel.

To access the advanced menu



- ▶ from the basic menu press 

Appears 
- ▶ press the  key once

Appears 
- ▶ press  to confirm and log in

This takes you to the settings menu.

To navigate in the menu

- ▶ use the icons  



To select a menu item and to confirm the changes made

- ▶ press  for 2 seconds

Confirming the change takes you to the next item.

To exit the menu

- ▶ press  for about 10 seconds

Appears 
- ▶ press  for about 10 seconds

The display turns off.
- ▶ or wait 30 seconds after the last action

The display is switched off automatically.

Menu items

Ad: Not used

di: Options for digital input

UC: Not used



Ac: Anti-stratification in cooling

Ah: Anti-stratification in heating

Fr: Not used

To select digital input

To change the digital input

- ▶ select 
- ▶ press  to change settings
- ▶ select CP for presence contact (default)
- ▶ select CO to cooling open
- ▶ select CC to cooling close
- ▶ press  to confirm



By default digital input is set to CP.





⚠ For return to the default settings, set the digital input to "CP".

⚠ By selecting one of the other inputs (CO,CC) the seasonality is locked. It is not possible to modify it through the key  of the control.

Set the anti-stratification function to cooling

To set the anti-stratification function in cooling mode

- ▶ select 
- ▶ press  to change settings



Appears 
- ▶ press  to move within the menu
- ▶ select  to enable the function
- ▶ press  to confirm changes





By default, the anti-stratification function in cooling is set to 

⚠ The anti-stratification function in cooling is to be set for appliances installed at low floor level equipped with an active air probe.

Set the anti-stratification function in heating mode

To set the anti-stratification function in heating mode

- ▶ select 
- ▶ press  to change settings

Appears 
- ▶ press  to move within the menu
- ▶ select  to enable the function
- ▶ press  to confirm changes

By default, the anti-stratification function in heating is set to 

⚠ The anti-stratification function in heating is to be set for appliances installed high up on the wall or ceiling equipped with an active air sensor.

4.5.3 Error signals

The PCB has a status LED.

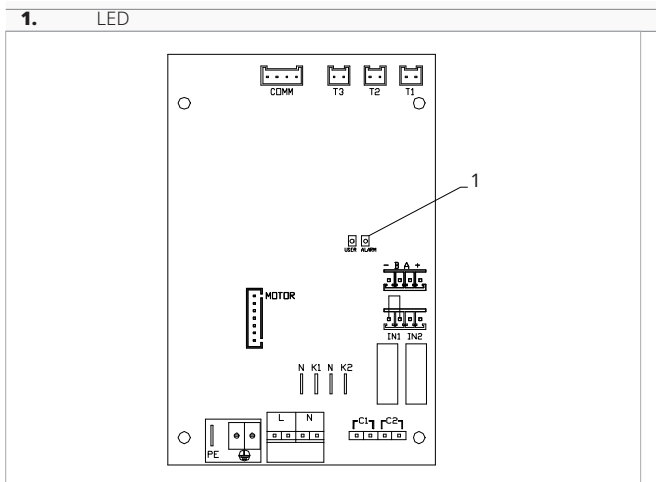

- ⚠ The flashing LED indicates errors.
- ⚠ It is possible to verify the meaning of the LEDs by means of the error code displayed on the touchpad.
- ⚠ To identify the error, please refer to "Visualization of alarms on display" p. 17.
- ⚠ With the LED on and no indication on the display, it is indicated that there are no errors.

4.5.4 Visualization of alarms on display

- ⚠ In the event of a malfunction, the display shows an alarm code.
- ⚠ In the event of an alarm, the device still maintains active functions.

- ▶ E1 Air temperature probe alarm T1 on PUB-30 board disconnected or with incorrect values (-10÷40)
The device is operating and the M7 control uses its own air probe.
- ▶ E2 Internal fan motor faulty or disconnected
None of the modes can be activated.
- ▶ E3 Water temperature sensor H2/T2 disconnected or faulty
None of the modes can be activated.
- ▶ CE Communication error
Errors in the communication between the touchpad control and the board. None of the modes can be activated.
The symbol ⚠ appears to indicate unsuitable radiant water.
- ▶ bL Key lock
To unlock the display, press $\oplus \ominus$ simultaneously for about 3 seconds.
- ▶ * Incorrect water temperature
In heating mode, the water temperature is below 30 °C
- ▶ * Incorrect water temperature
In cooling mode, the water temperature is above 20 °C.
** flashing*

5. TOUCHPAD CODING PCZ-EWA844

5.1 Interface

The touchpad control is supplied as standard on board the unit, does not require any connections and enables:

- show the operating status

- show any alarms
- select the various functions

1. Display area
2. Keys area

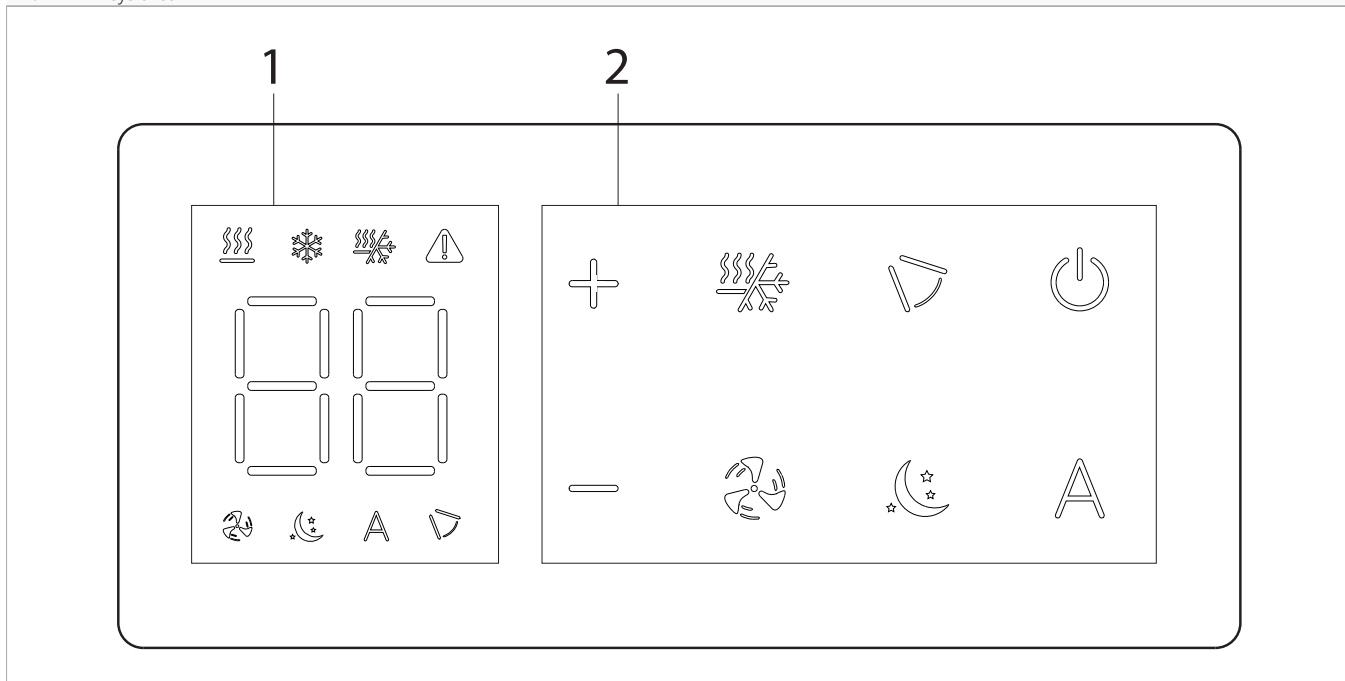

5.2 Description

On-board control with integrated Wi-Fi module, with continuously modulating thermostat.

5.3 PCB

The PCB is included in the supply.

M1	DC fan motor
	Ground connection
230~50	Power supply connection 230 V / 50 Hz / 1 A
Y1	Water electrovalve
CH/C1	Cooling request contact (for example chiller or reversible heat pump). Activated in parallel with the solenoid valve output (Y1) with 1 minute delay when the fancoil is in cooling mode and is on call (potential-free contact max. 1 A).
BO/C2	Heating request contact (for example boiler or heat pump). Activated in parallel with the output of the solenoid valve (Y1)

with 1 minute delay when the fancoil is in heating mode and is on call (potential-free contact max. 1 A).

CP	Presence contact (normally open)
IN1	Input for potential-free contact 1
AIR/T1	Air temperature probe
H2/T2	Water temperature probe
DU	Touchpad
PU	Electronic board on the unit
WF	Card for Wi-Fi connection

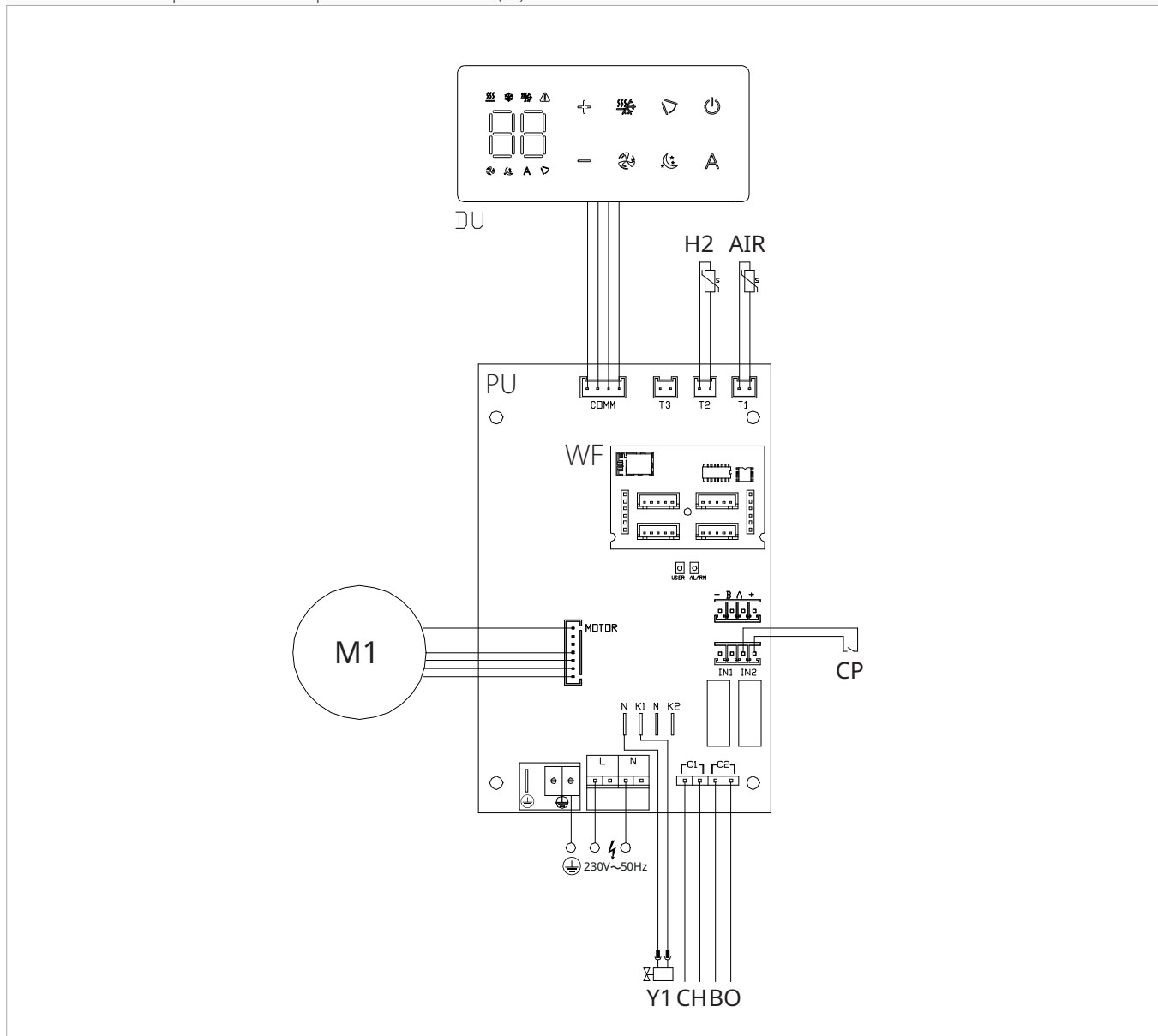

Through the water temperature probe H2/T2 (10 k Ω) located in the thermowell on the unit's coil, the temperature setpoints for fan stop are controlled:

- minimum temperature in heating mode (30 °C)
- maximum temperature in cooling mode (20 °C)

! The printed circuit board provides for operation without a water probe. In this case, the fan stop thresholds are ignored.

5.4 Connections

5.4.1 Presence contact CP

Through this device it is possible to connect an external control signal that inhibits the operation of the control signal, for example:

- opening window contact
- remote on/off
- infrared presence sensor
- activation badge

Function

The contact is normally open (NO).

- ▶ when closing the CP contact, connected to a potential-free contact, the device switches to stand-by mode
CP appears on the display.

- ▶ At the touch of a button on the display the symbol  flashes.

⊖ It is forbidden to connect the CP input to that of another unit electronic board. Use separate contacts.

The CP presence contact can be configured for heating and cooling operation via the "To select digital input" *p. 21* settings menu item (digital input).



5.5 Functions

5.5.1 Basic menu

To access the basic menu



- ▶ with the display off, hold down  for 10 seconds

The device turns on and  appears

- ▶ keep pressed until the indication  appears
- ▶ release the  key

The symbol  appears

To navigate in the menu

- ▶ use the icons  

To select a menu item and to confirm the changes made

- ▶ press the icon 

Confirming the change takes you to the next item.

To exit the menu

- ▶ press the icon  for 10 seconds
- ▶ or wait 30 seconds after the last action
The display is switched off automatically.

Menu items

ot: AIR probe offset (air probe setting)

CF: Scale



ub: Buzzer volume

uu: Wi-Fi reset





up: Wi-Fi pairing

ho: Hotel Mode

Set AIR probe offset



 The set value changes by 1 °C each press of the  and  buttons.

To set the air probe offset

- ▶ select 
- ▶ press  to change settings
- ▶ increase or decrease the value with the icons  
- ▶ press  to confirm
*By default it is set to 0.
The range of settings is from a minimum of -9°C to a maximum of +9°C.*





Scale

To change the temperature unit of measure

- ▶ select 
- ▶ press  to change settings
- ▶ select °C or °F
- ▶ press  to confirm
By default the temperature unit of measure is ° C.

Adjusting buzzer volume











To change the volume

- ▶ select 
- ▶ press  to change settings
- ▶ increase or decrease the value with the icons  
- ▶ press  to confirm
The volume setting range is from 00 (min) to 03 (max).

 The volume changes after confirming the modification.



Wi-Fi reset



To reset the Wi-Fi credentials and return the device to its original configuration

- ▶ select 
- ▶ press  to change settings
- ▶ use the   icons in sequence
Appears  .
- ▶ press 
- ▶   appears to reset Wi-Fi credentials.
- ▶ press  to confirm
Credentials have been reset.

Activate Wi-Fi

To activate Wi-Fi

- ▶ select 
- ▶ press  to change settings
- ▶ use the   icons in sequence
Appears  .

- ▶ press 
- ▶  appears to enable Wi-Fi pairing.
- ▶ press  to confirm

⚠ The device remains visible on Aquarea Home App for the first 15 minutes after the device is switched on.

Setting the Hotel Mode

To set the Hotel mode

- ▶ select 
- ▶ select YES to turn on Hotel mode
- ▶ select NO to turn off the Hotel mode
By default the device is set to NO.

Activating the Hotel mode:





- the Autochangeover function is deactivated
- the temperature setting range is reduced, in Cooling you can set from 22 °C to 28 °C, in Heating you can set from 16 °C to 24 °C

5.5.2 Advanced Menu



⚠ To access the setup menu, it is necessary to access the Basic menu. See section "Basic menu" p. 20.

The special functions menu can be accessed via the control panel.

To access the advanced menu

- ▶ from the basic menu press 
- Appears .*
- ▶ press the  key once
Appears .
- ▶ press  to confirm and log in
This takes you to the settings menu.



To navigate in the menu

- ▶ use the icons  

To select a menu item and to confirm the changes made

- ▶ press  for 2 seconds
Confirming the change takes you to the next item.

To exit the menu

- ▶ press  for about 10 seconds
Appears .
- ▶ press  for about 10 seconds
The display turns off.
- ▶ or wait 30 seconds after the last action
The display is switched off automatically.

Menu items

Ad: Not used

of: Options for digital input

UC: Not used



Ac: Anti-stratification in cooling

Ah: Anti-stratification in heating

Fr: Not used

To select digital input

To change the digital input







- ▶ select 
- ▶ press  to change settings
- ▶ select CP for presence contact (default)
- ▶ select CO to cooling open
- ▶ select CC to cooling close
- ▶ press  to confirm
By default digital input is set to CP.

⚠ For return to the default settings, set the digital input to "CP".

⚠ By selecting one of the other inputs (CO,CC) the seasonality is locked. It is not possible to modify it through the key  of the control.

Set the anti-stratification function to cooling







To set the anti-stratification function in cooling mode

- ▶ select 
- ▶ press  to change settings
Appears .
- ▶ press  to move within the menu
- ▶ select  to enable the function
- ▶ press  to confirm changes
By default, the anti-stratification function in cooling is set to .





⚠ The anti-stratification function in cooling is to be set for appliances installed at low floor level equipped with an active air probe.

Set the anti-stratification function in heating mode

To set the anti-stratification function in heating mode

- ▶ select 
- ▶ press  to change settings
Appears 
- ▶ press  to move within the menu
- ▶ select  to enable the function
- ▶ press  to confirm changes
By default, the anti-stratification function in heating is set to 





 The anti-stratification function in heating is to be set for appliances installed high up on the wall or ceiling equipped with an active air sensor.

- ▶ CE Communication error
Errors in the communication between the touchpad control and the board. None of the modes can be activated.
The symbol  appears to indicate unsuitable radiant water.
- ▶ bL Key lock
To unlock the display, press  \Rightarrow simultaneously for about 3 seconds.
- ▶ * Incorrect water temperature
In heating mode, the water temperature is below 30 °C
- ▶ * Incorrect water temperature
In cooling mode, the water temperature is above 20 °C.
** flashing*

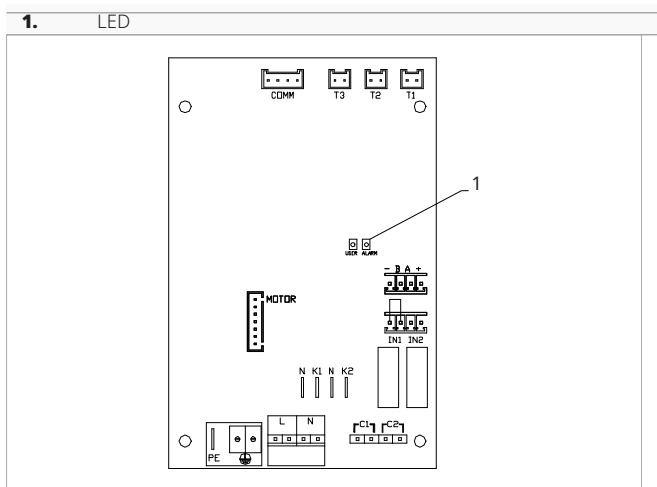

5.5.3 Error signals

The PCB has a status LED.



-  The flashing LED indicates errors.
-  It is possible to verify the meaning of the LEDs by means of the error code displayed on the touchpad.
-  To identify the error, please refer to "Visualization of alarms on display" **p. 22**.
-  With the LED on and no indication on the display, it is indicated that there are no errors.

5.5.4 Visualization of alarms on display

-  In the event of a malfunction, the display shows an alarm code.
-  In the event of an alarm, the device still maintains active functions.

- ▶ E1 Air temperature probe alarm T1 on PUB-30 board disconnected or with incorrect values (-10÷40)
The device is operating and the M7 control uses its own air probe.
- ▶ E2 Internal fan motor faulty or disconnected
None of the modes can be activated.
- ▶ E3 Water temperature sensor H2/T2 disconnected or faulty
None of the modes can be activated.

6. PREPARATION FOR CONNECTING WALL CONTROLS

6.1 Preliminary warnings

- ⚠ The procedure described here is required for connection of wall controls (PCZ-EEB749 - PCZ-EFB749 - PCZ-B10842).**

6.2 Preparation for command connection

6.2.1 Accompanying material

Accompanying the unit, contained in a bag placed on the cover of the electrical box, are:

- 1 terminal for power supply connection (230V~50Hz)
- cable gland
- 1 terminal for serial connection (-BA+)
- screws

6.2.2 Preliminary warnings

- ⚠** Before carrying out any work, please ensure the power supply is disconnected.
- ⚠** All operations of an electrical nature must be carried out by qualified personnel having the necessary training, who understands the legal requirements, and is informed about the risks related to such operations.
- ⚠** All connections must be made following the regulations in force in the country of installation.
- ⚠** The unit must only be powered after work has been completed.
- ⚠** Isolate and lock off the main circuit breaker before making any electrical connections and performing any type of operation.
- ⚠** Access to the electrical panel is only permitted to qualified personnel.
- ⚠** Refer to the respective section of the control, used to make the electrical connections.

6.2.3 Device preparation

Before proceeding with the installation, it is necessary to remove some elements from the appliance.

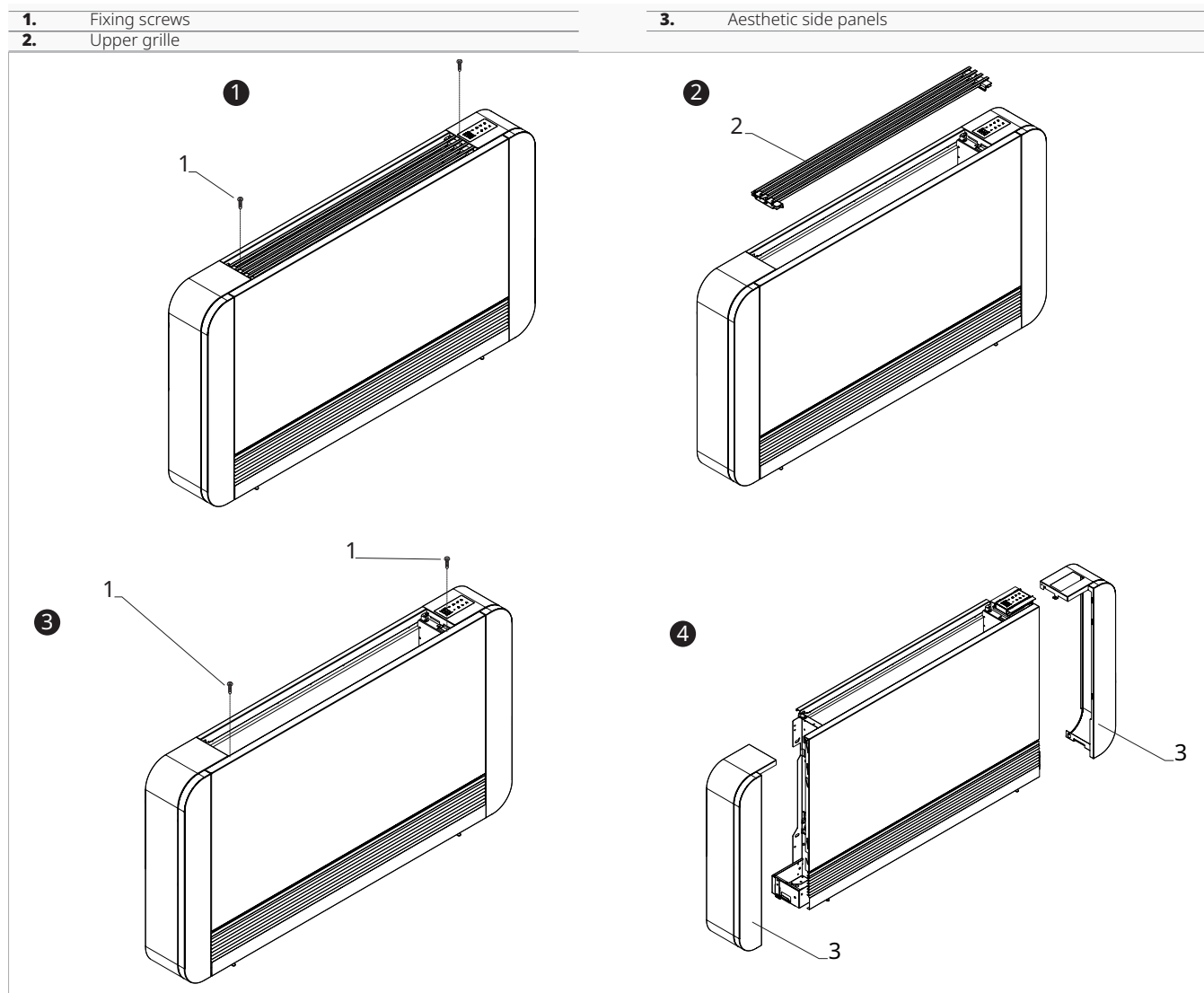

To remove the grille:

- ▶ remove the fixing screws
- ▶ lift up and remove the upper grille

To remove the aesthetic side panels:

- ▶ remove the fixing screws
- ▶ slightly move the side panel outwards
- ▶ lift and remove the side panel

6.2.4 Installation of electrical connection box

- ⚠ Normally the unit leaves the factory with the electrical box mounted.
- ⚠ In exceptional cases, the electrical box can be installed at a later stage.

- 1. Electrical back box
- 2. Notches
- 3. Holes

- 4. Fixing screws
- 5. Cable strain relief clamp
- 6. Fixing of ground cable

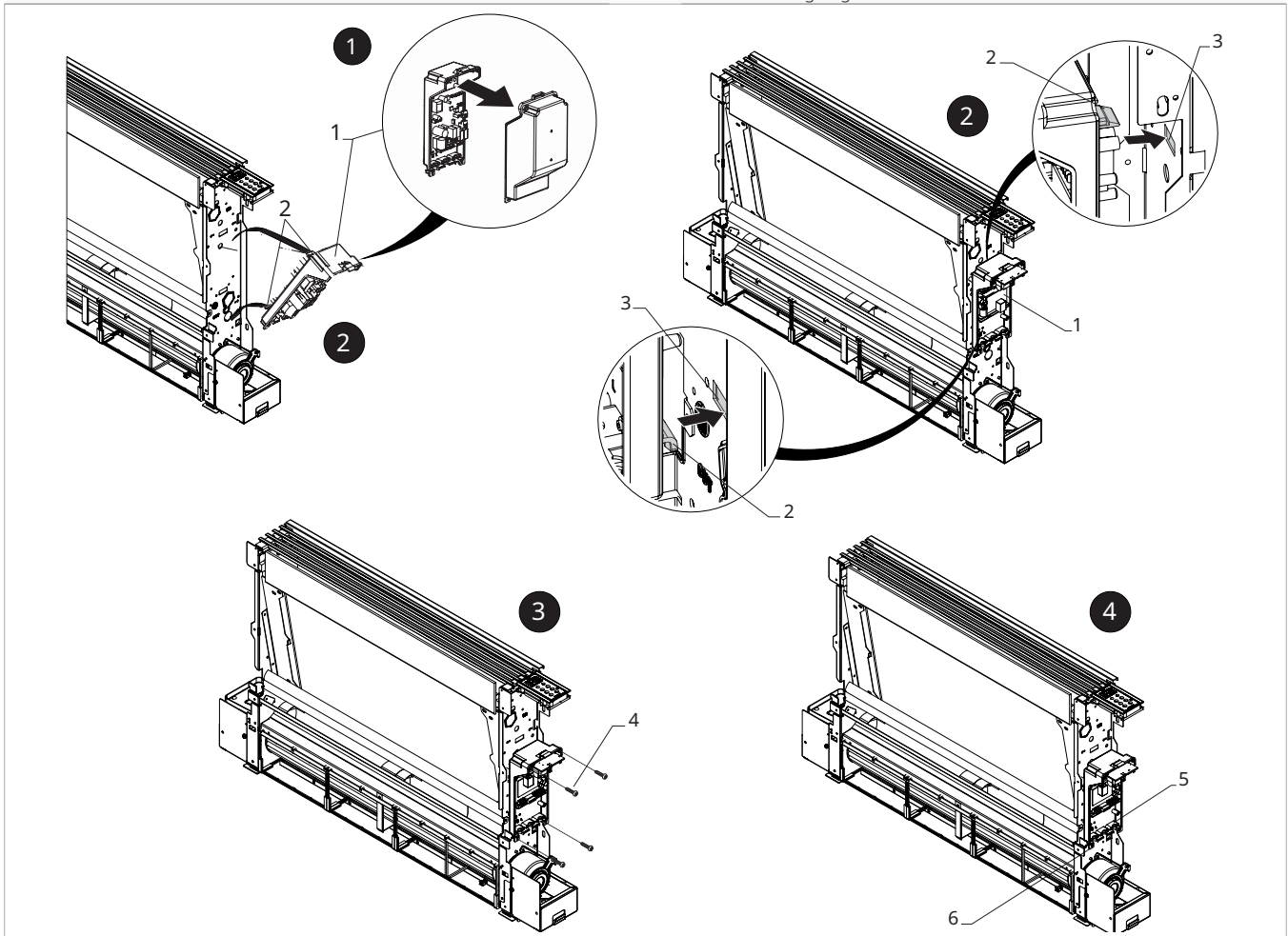

To install the electrical box:

- ▶ open the electrical box
- ▶ place the base of the electrical box on the side of the appliance
- ▶ Wedge the notches of the electrical box into the appropriate holes on the side of the appliance
- ▶ secure the electrical box with the fixing screws provided
- ▶ secure the ground cable to the structure of the appliance with the screw provided

⚠ The minimum force that must be exerted for starting is approximately 2 N.

- ▶ connect the connector to the MOTOR quick connector on the printed circuit board
- ▶ connect the water probe to the T2 connector on the device

⚠ The water temperature probe monitors the temperature inside the coils and determines fan start-up according to preset parameters. (winter minimum and summer maximum functions)

⚠ Check that the probe is correctly positioned in the compartment on the coil.

- ▶ connect the electrical wiring
- ▶ tidy up the cables
- ▶ secure the cables using the grommets provided
- ▶ close the electrical box

- ▶ secure the electrical box with the fixing screws provided

6.2.5 Connection of MOTOR connector

To connect the MOTOR connector

- ▶ connect the motor quick connector (MOTOR) to the connector on the printed circuit board

6.2.6 Completed assembly

Completed assembly

- ▶ place the cover of the electrical box
- ▶ fix with screws
- ▶ reassemble the aesthetic side panel
- ▶ fix with screws
- ▶ replace the upper grille
- ▶ fix with screws

6.2.7 Access to the terminal block

- 1. Fixing screws
- 2. Cover of the electrical box

- 3. Terminal block for wiring

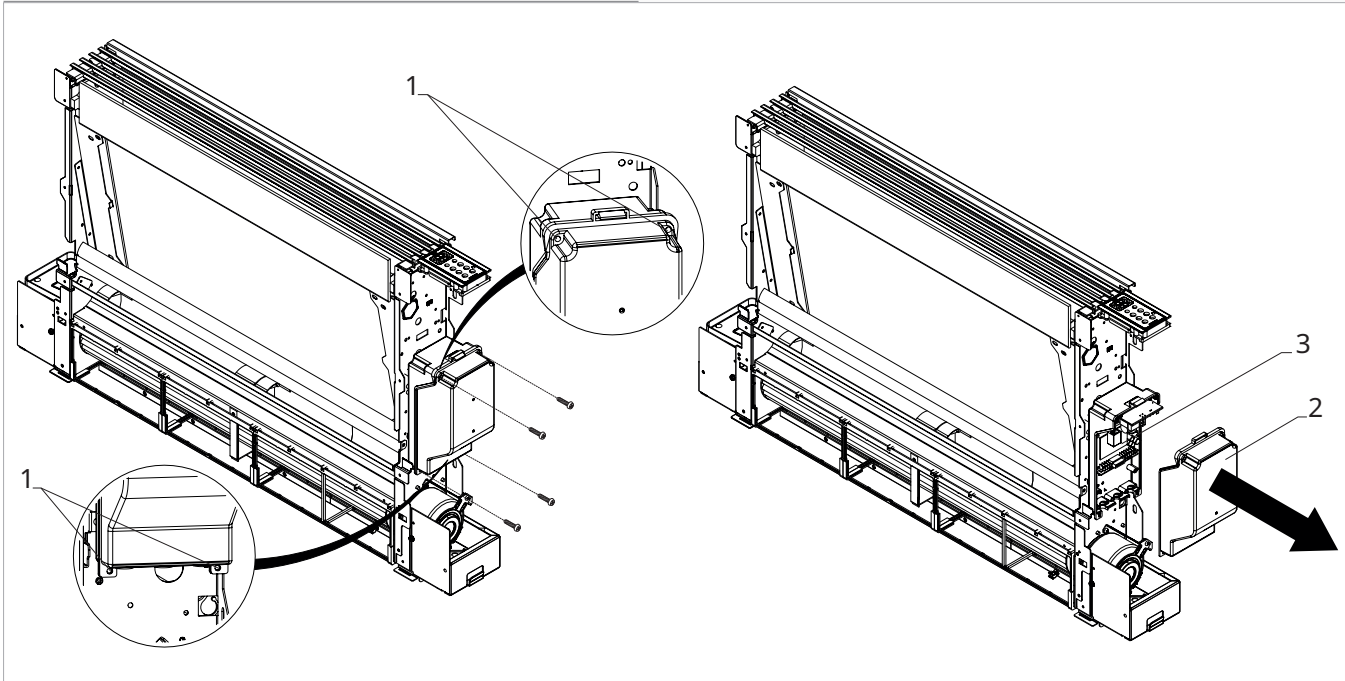

⚠ Before carrying out any work, please ensure the power supply is disconnected.

To access:

- ▶ if installed, remove the movable cover panel

To access the connections:

- ▶ unscrew the fixing screws of the electric box
- ▶ remove the lid from the junction box

- 1. Terminal block for wiring
- 2. Power supply cables
- 3. Quick-connect terminal
- 4. Earth connection

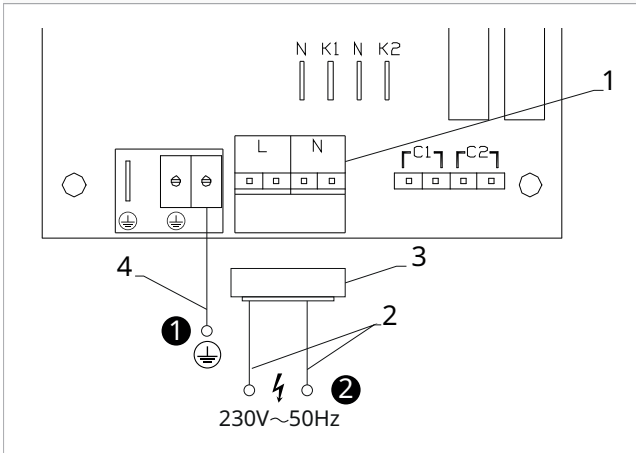

To make the connections:

- ▶ use the supplied quick terminal
- ▶ connect phase and neutral (230 V~50 Hz) to the quick terminal
- ▶ connect the quick-connect terminal to the terminal block
- ▶ Connect the earthing wire (⊕) to the terminal provided on the electrical panel

⚠ Refer to the information in the wiring diagram of the unit you are installing.

⚠ Please refer to the sections of the respective controls for indications of electrical connections.

⚠ The electrical connection can be made by a cable recessed into the wall as indicated on the installation template (connection recommended for installation of the device at the top of the wall).

⚠ It is necessary to check that the power supply is provided with appropriate protection against electrical shorts and/or overloads

7. WALL-MOUNTED CONTROL COD. PCZ-EEB749

7.1 Interface

1. Display area
2. Keys area

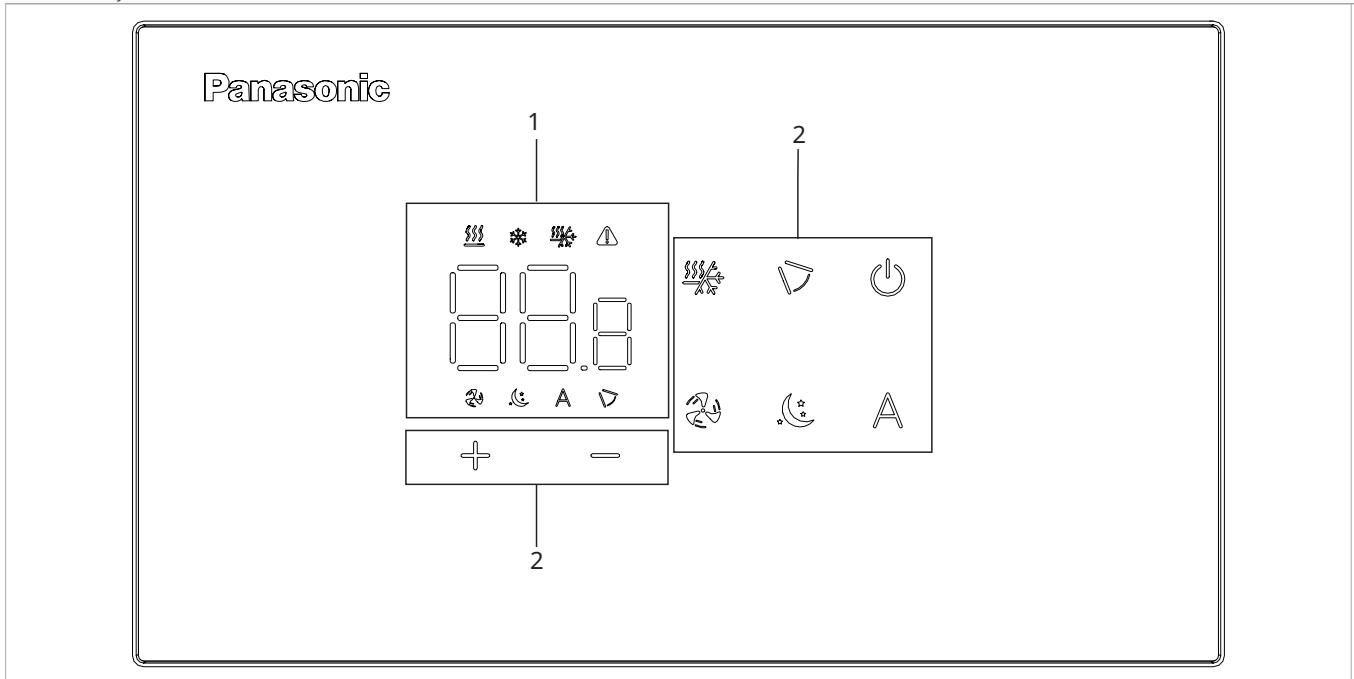

7.2 Installation

7.2.1 Description

The wall-mounted remote control is an electronic LED thermostat with a touch interface, with the possibility of controlling multiple appliances equipped with the same electronic board. It is equipped with a temperature and humidity probe.

⚠ The control can manage a maximum of 16 units.

7.2.2 Mounting

⚠ The control panel must be mounted in an electrical back box.

⚠ A wall must be prepared to accommodate the electrical box before installing the wall control.

⚠ Ensure that:

- the wall supports the weight of the appliance
- the section of the wall does not contain piping or electrical lines
- the functionality of load-bearing elements is not compromised

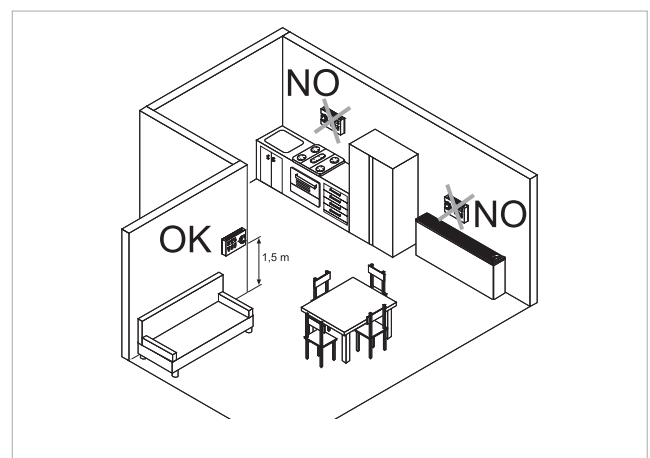

The wall-mounted remote control must be installed:

- on internal walls
- at a height of about 1,5 m from the floor

⚠ Should the control be located in an area utilised by persons with reduced physical capabilities, please refer to local regulations.

- away from doors or windows

- away from heat sources (heaters, convectors, stoves, direct sunlight)

⚠ The wall control is provided inside the package already assembled.

1. Back plate
2. Wall-mounted control panel

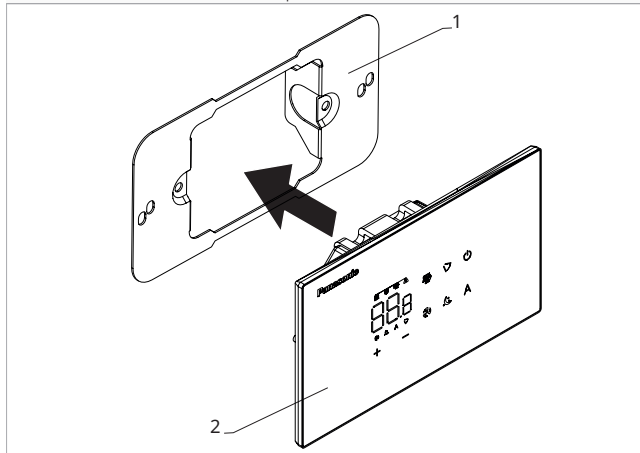

Before wall installation:

- ▶ separate the back plate from the control panel

1. Fixing screws
2. Back plate
3. Holes for fixing to electrical box
4. Electrical back box

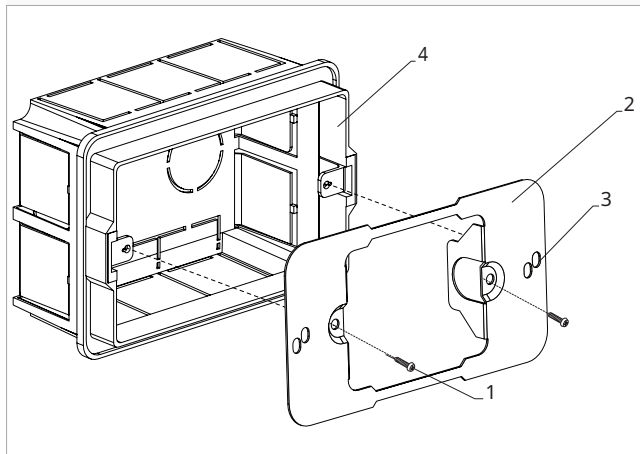

For wall mounting of the control panel:

- ▶ fix the back plate to the electrical back box with screws
- ▶ connect the electrical wiring

⚠ Ensure that the air probe sensor is not affected by air currents, whether warm or cold, coming from the recessed wall box.

⚠ To avoid interference in temperature measurement:

- seal the cable-entry conduits tightly so that they do not allow air to pass through.
- seal any openings in the box or the wall that could connect the back of the thermostat with the air circulating in the wall cavities

⚠ proper sealing ensures the correct operation of the sensor and the reliability of thermal regulation

⚠ Before making the connections, please verify that the control terminal block is on the right-hand side.

⚠ It is mandatory to use ferrules on all conductors, both on the board side and on the wall-mounted terminal block side, to prevent permanent damage to the equipment.

⚠ There are multiple holes on the base of the control. The use of the holes depends on the model of the electrical back box used.

1. Electrical back box
2. Back plate
3. Wall-mounted control panel

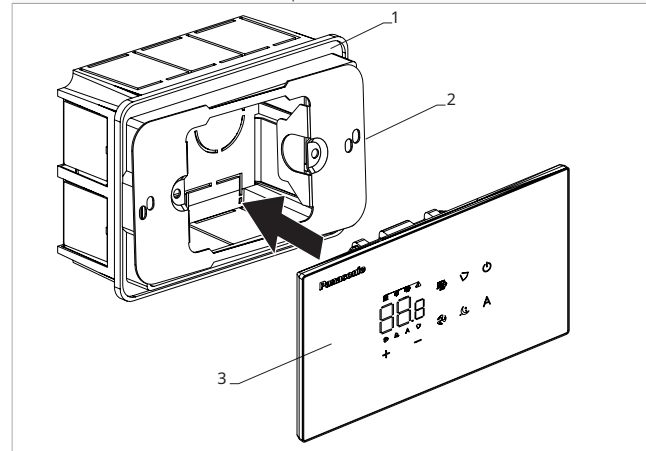

- ▶ Close the control panel

⚠ Pay attention not to crush the conductors when you close the control.

7.3 Single connection diagram

M1	DC fan motor
	Ground connection
230~50	Power supply connection 230 V / 50 Hz / 1 A
Y1	Water solenoid valve (230 V / 50 Hz / 1 A power output)
CH/C1	Cooling request contact (for example chiller or reversible heat pump). Activated in parallel with the solenoid valve output (Y1) with 1 minute delay when the fancoil is in cooling mode and is on call (potential-free contact max. 1 A).
BO/C2	Heating request contact (for example boiler or heat pump). Activated in parallel with the output of the solenoid valve (Y1)

CP	Presence contact (normally open)
+BA-	Serial connection for wall-mounted remote control (respect AB polarization)
IN1	Potential-free input 1(not active)
H2/T2	2-pipe water temperature probe
LU	Electronic board for pairing control and device
PU	Electronic board on the unit
RC	Wall-mounted control

with 1 minute delay when the fancoil is in heating mode and is on call (potential-free contact max. 1 A).

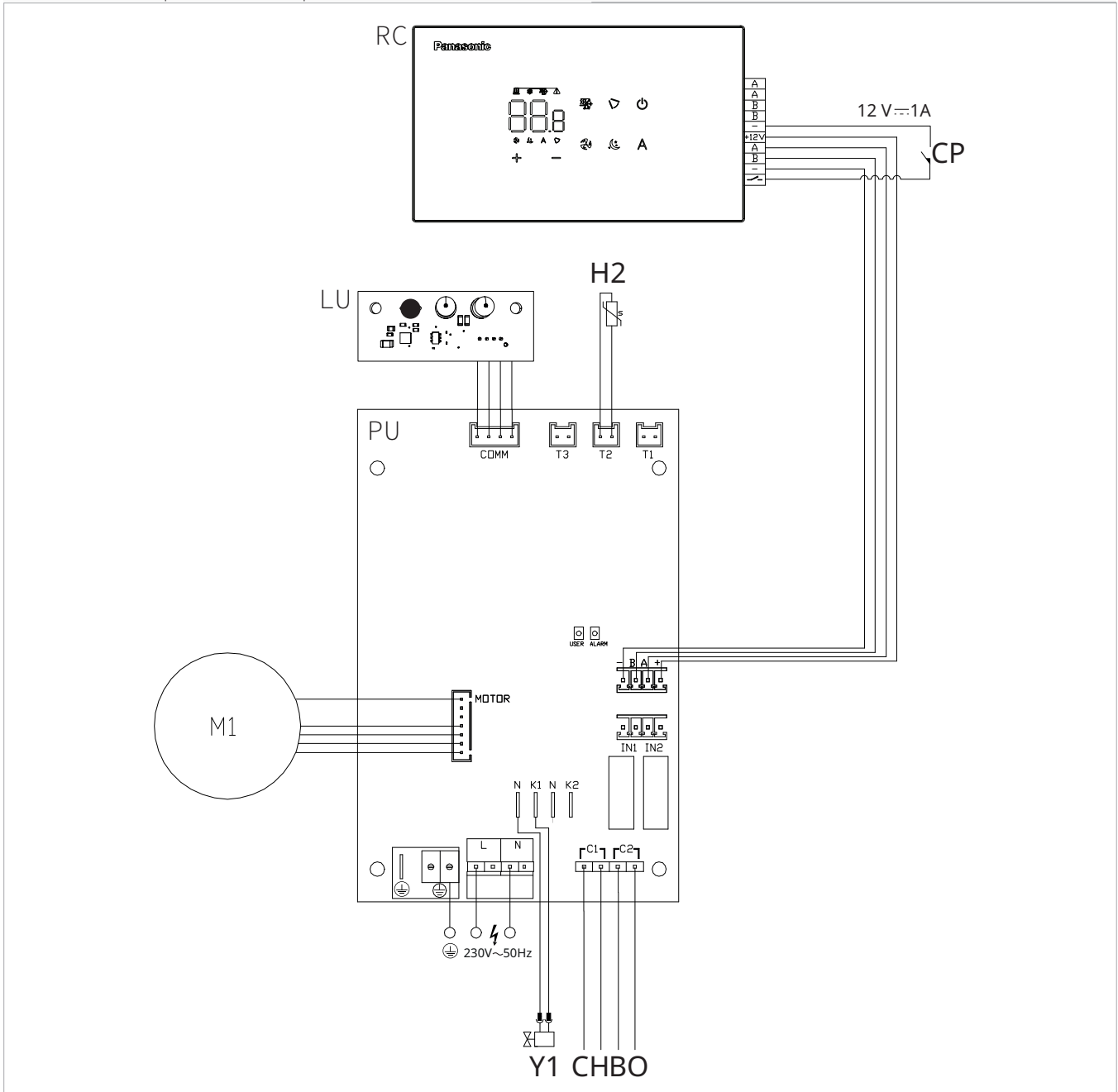

7.4 Multiple connection diagram

- | | | | |
|----|--------------------------------------|----|--------------------------------------|
| 1. | Wall-mounted control panel | 3. | PCB |
| 2. | Terminal block for device connection | 4. | Board for pairing control and device |

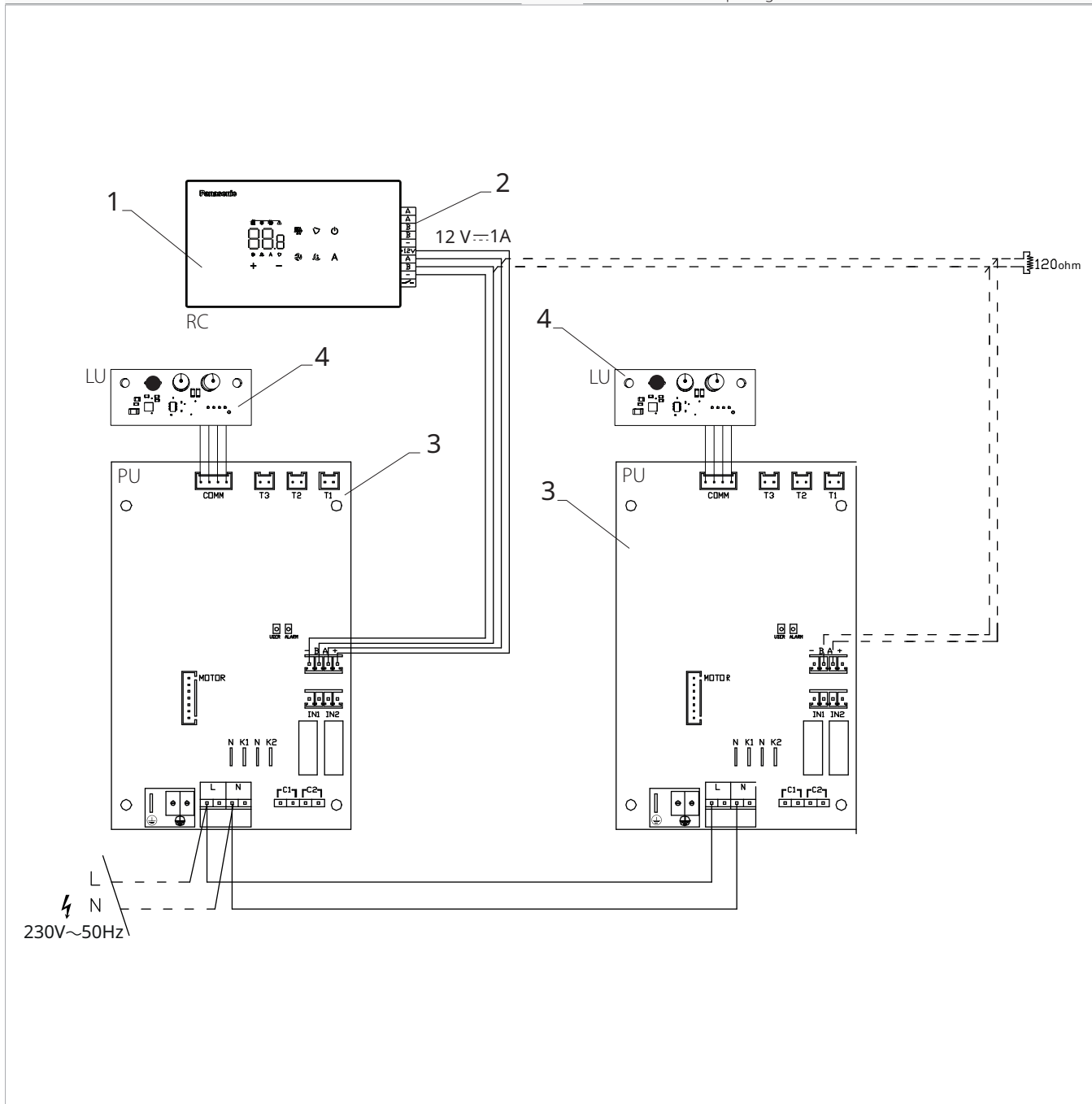

⚠ With multiple command linkage, it is mandatory to perform command-to-device matching. See section "Pairing of control and unit" p. 34.

7.5 Connections

7.5.1 Preliminary warnings

- ⚠ The terminals for connecting the control panel and the presence contact CP are placed in a plastic bag and positioned inside the cover of the electrical box.

1. Terminal blocks

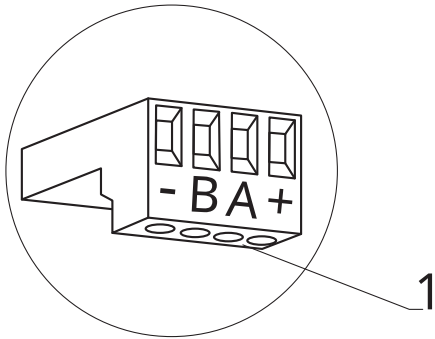

The terminals accept:

- rigid or flexible wires with a 0.2 to 1 mm² cross-section
- rigid or flexible wires with 0,5 mm² cross-section if two wires are connected to the same terminal block
- rigid or flexible wires with 0,75 mm² cross-section if the wires have wire end ferrules with a plastic collar

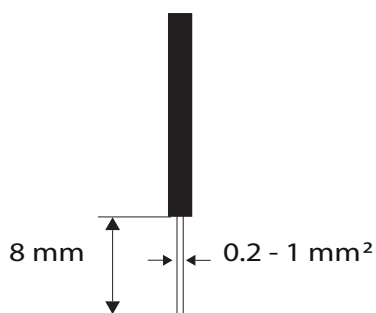

To connect the cables:

- ▶ strip 8 mm of the wire
- ▶ if the wire is rigid, you can insert it easily whereas
- ▶ if it is flexible, use appropriate crimp terminals
- ▶ push the wire in completely
- ▶ check the right fixing by pulling it gently

7.5.2 Control Panel

- ⚠ The control panel for wall control must be ordered separately.

Terminal block position:

1. Terminal block (Back view panel)

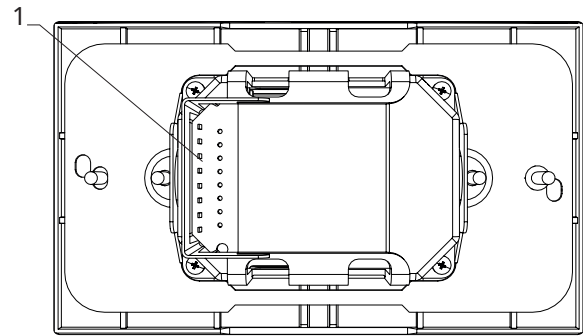

1. Terminal blocks

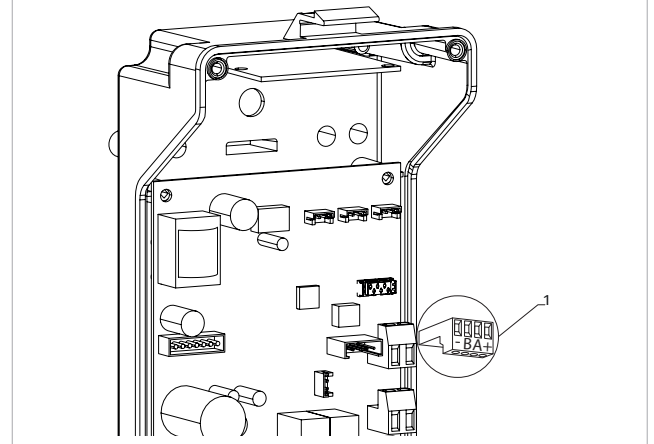

To connect the wall control panel to the board:

- ▶ connect the power supply cables to the + - terminals
- ▶ connect the Modbus serial connection cables to terminals A and B

7.5.3 Presence contact CP

Through this device it is possible to connect an external control signal that inhibits the operation of the control signal, for example:

- opening window contact
- remote on/off
- infrared presence sensor
- activation badge

Function

The contact is normally open (NO).

- ▶ when closing the CP contact, connected to a potential-free contact, the device switches to standby mode

CP appears on the display.

- ▶ At the touch of a button on the display the symbol ⚠ flashes.

- ⊖ It is forbidden to connect the CP input to that of another unit electronic board. Use separate contacts.

The CP presence contact can be configured for heating and cooling operation via the "To select digital input" *p. 34* settings menu item (digital input).

7.5.4 RS485 Serial Connection

The wall-mounted remote control can be connected through an RS485 serial line to one or more devices, up to a maximum of 16.

The devices must be equipped with an electronic board suitable for remote control.

For the connection:

- ▶ follow the indication on the connection diagram
- ▶ connect respecting the polarity indication A and B

⚠ Use a two core cable shielded cable suitable for the RS485 serial connection with a minimum section of 0,35 mm².

⚠ Keep the two core cable separate from power supply cable by a minimum of 50 mm.

⚠ Create a wire path in order to minimize the length of the lead wire.

⚠ Complete the line with the 120 Ω resistor.

⊖ It is forbidden make star connections.

⚠ In the case of a connection between several devices, it is mandatory to carry out the matching between control and device. See section "Pairing of control and unit" *p. 34*.



7.6 Functions

7.6.1 Basic menu

To access the basic menu



- ▶ with the display off, hold down  for 10 seconds

The device turns on and  appears

- ▶ keep pressed until the indication  appears
- ▶ release the  key

The symbol  appears

To navigate in the menu

- ▶ use the icons  

To select a menu item and to confirm the changes made

- ▶ press the icon 
- Confirming the change takes you to the next item.*

To exit the menu

- ▶ press the icon  for 10 seconds
 - ▶ or wait 30 seconds after the last action
- The display is switched off automatically.*

Menu items

ot: AIR probe offset (air probe setting)

ur: Not used

ut: Probe Offset PT4

uS: Humidity setpoint

uI: Humidity hysteresis

CF: Scale

ub: Buzzer volume





uu: Not used

up: Not used

ho: Hotel Mode

Set AIR probe offset





To set the air probe offset

- ▶ select 
 - ▶ press  to change settings
 - ▶ increase or decrease the value with the icons  
 - ▶ press  to confirm
- By default it is set to 0.
The setting range is from a minimum of -12.0 °C to a maximum of 12.0 °C.*

Set probe offset RH





⚠ Modify only after real deviations from an actual measurement has been established with professional equipment.

To set the RH probe offset

- ▶ select 
- ▶ press  to change settings
- ▶ increase or decrease the value with the icons  
- ▶ press  to confirm





Set the humidity setpoint

To set the humidity setpoint

- ▶ select 
 - ▶ press  to change settings
 - ▶ increase or decrease the value with the icons  
 - ▶ press  to confirm
- The setting range is from 20.0% to 90.0%.*



Setting the humidity hysteresis

To set the humidity hysteresis

- ▶ select 
- ▶ press  to change settings
- ▶ increase or decrease the value with the icons  
- ▶ press  to confirm
The setting range is from 1 (min) to 30 (max).





Scale

To change the temperature unit of measure

- ▶ select 
- ▶ press  to change settings
- ▶ select °C or °F
- ▶ press  to confirm
By default the temperature unit of measure is °C.

Adjusting the volume

To change the volume

- ▶ select 
- ▶ press  to change settings
- ▶ increase or decrease the value with the icons  
- ▶ press  to confirm
The volume setting range is from 00 (min) to 03 (max).

 The volume changes after confirming the modification.

Setting the Hotel Mode

To set the Hotel mode

- ▶ select 
- ▶ select YS to turn on Hotel mode
- ▶ select NO to turn off the Hotel mode
By default the device is set to NO.

Activating the Hotel mode:





- the Autochangeover function is deactivated
- the temperature setting range is reduced, in Cooling you can set from 22 °C to 28 °C, in Heating you can set from 16 °C to 24 °C

7.6.2 Advanced Menu



 **To access the setup menu, it is necessary to access the Basic menu. See section "Basic menu" p. 32.**

Through the control it is possible to access the settings menu.

To access the advanced menu

- ▶ from the basic menu press 
- Appears 
- ▶ press the  key once
- Appears 
- ▶ press  to confirm and log in
The advanced menu is accessed.



To navigate in the menu

- ▶ use the icons  

To select a menu item and to confirm the changes made

- ▶ press  for 2 seconds
Confirming the change takes you to the next item.

To exit the menu

- ▶ press  for about 10 seconds
Appears 
- ▶ press  for about 10 seconds
The display turns off.
- ▶ or wait 30 seconds after the last action
The display is switched off automatically.

 After 30 seconds from the last action the control returns to the start screen and the last chosen values are recorded.

Menu items

Ad: Options for Modbus address

di: Options for digital input

t1: Select air probe M7/PU

rH: Radiant heating options with R20

rC: Radiant cooling options with R20

UC: Not used

Ac: Anti-stratification in cooling









Ah: Anti-stratification in heating

Ed: Not used

Fr: Not used



Set device address for communication

To set the Modbus address

- ▶ select 
- ▶ press  to change settings
- ▶ press   simultaneously to change the value shown on the display
The value shown in the display flashes.
- ▶ press  to confirm
- ▶ increase or decrease the value with the icons  
- ▶ press  to confirm
*By default the Modbus address is set to 01.
The setting range is from 01 (min) to 99 (max).*

To select digital input

To change the digital input



- ▶ select 
 - ▶ press  to change settings
 - ▶ select CP for presence contact (default)
 - ▶ select CO to cooling open
 - ▶ select CC to cooling close
 - ▶ press  to confirm
- By default digital input is set to CP.*

⚠ For return to the default settings, set the digital input to "CP".

⚠ By selecting one of the other inputs (CO,CC) the seasonality is locked. It is not possible to modify it through the key  of the control.

Select air probe M7/PU

To select the M7/PU air probe

- ▶ select t1
 - ▶ press  to change settings
 - ▶ select 0 to use air probe M7
 - ▶ select 1 to obtain the values of the T1 probes of the connected PU boards
 - ▶ press  to confirm
- By default, the digital input is set to 0.*

⚠ In the case of paired PU boards, the M7 series control unit takes an average of the probe values.

Set radiant options in heating with R20

⚠ To change the rH function, it is necessary to have the accessory MZS - Single zone module for radiant system.

⚠ To change the settings, please refer to the Instruction Sheet of the accessory MZS - Single zone module for radiant system.







Set radiant options to cooling with R20

⚠ To change the rC function, it is necessary to have the accessory MZS - Single zone module for radiant system.

⚠ To change the settings, please refer to the Instruction Sheet of the accessory MZS - Single zone module for radiant system.

Set the anti-stratification function to cooling







To set the anti-stratification function in cooling mode

- ▶ select 
 - ▶ press  to change settings
 - ▶ Appears 
 - ▶ press  to move within the menu
 - ▶ select  to enable the function
 - ▶ press  to confirm changes
- By default, the anti-stratification function in cooling is set to .*

⚠ The anti-stratification function in cooling is to be set for appliances installed at low floor level equipped with an active air probe.

Set the anti-stratification function in heating mode

To set the anti-stratification function in heating mode

- ▶ select 
 - ▶ press  to change settings
 - ▶ Appears 
 - ▶ press  to move within the menu
 - ▶ select  to enable the function
 - ▶ press  to confirm changes
- By default, the anti-stratification function in heating is set to .*



⚠ The anti-stratification function in heating is to be set for appliances installed high up on the wall or ceiling equipped with an active air sensor.

7.6.3 Pairing of control and unit

⚠ The matching procedure between control and luminaire is mandatory and allows the reception of any alarms.

⚠ In the case of a failed pairing between control and device, and the related appearance of error E8, after 10 minutes, the control enables broadcast communication. The E8 error is then eliminated and the control sends signals to all devices without receiving any feedback.

To pair the control with the unit

- ▶ with control switched on, at the same time press  and  for about 10 seconds
- In the display area, where the setpoint is indicated, appears the number of connected devices. The displayed value flashes.*

1. Red LED
2. Green LED
3. Black button
4. Electrical back box

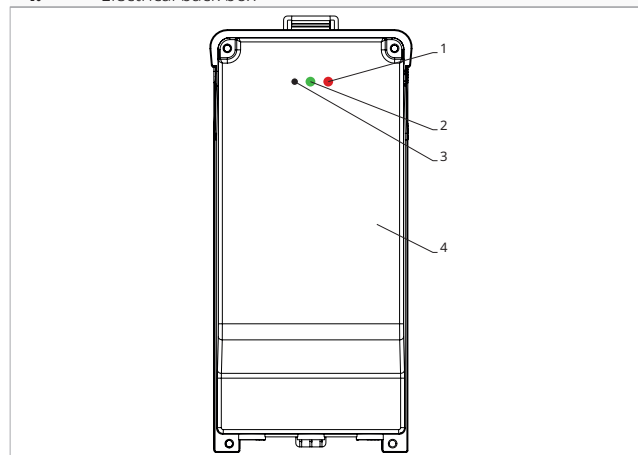

On the electrical box on the unit

- ▶ press the black button for 3 seconds
*The green LED flashes.
The red LED is on.*
- ▶ wait for the procedure to complete
The green LED stops flashing.





On the wall mounted control panel

*Appear the number assigned to the fancoil.
Then appears the number of connected devices.*







- ▶ press  to exit the menu

⚠ To reset the pairing settings, it is first necessary to access the basic menu. See section "Basic menu" p. 32.



To reset pairing settings

- ▶ access the basic menu
- ▶ press 
- ▶ press 
- All the way to the  menu.*
- ▶ press 









To reset a single fancoil

- Appears *
- ▶ press 
 - Appears *
 - ▶ press  to log in
 - ▶ use the   icons to move inside the menu
The assignment numbers assigned to the fancoils appears.
 - ▶ select the fancoil to be reset
 - ▶ press  to confirm
*-- appears, with an acoustic signal.
The device is removed.*

To exit the  setting

- ▶ press  for 5 seconds
*Exit the  setting.
Back to menu 02.*

To reset all fancoils

- Appears *
- ▶ press  until  appears
Appears 
 - ▶ press  to confirm
 - ▶ use the   icons to move inside the menu
 - ▶ select No to maintain all fancoils
 - ▶ select Yes to reset the fancoils
 - ▶ press  to confirm

LED interface operation on the electrical box**If the device is being paired**

The green LED flashes.

If the device is paired and functioning

The green LED is on.

If the device has not been paired and is not functional

*The green LED is off.
The red LED is on.*

If the device is in alarm status

The red LED flashes.

⚠ The red LED flashes according to the type of alarm. To check the alarm type, please refer to the following "Error signals" p. 35 section.

If communication with the board is missing

The green and red LEDs will flash once every second.

7.6.4 Error signals

The PCB has a status LED.

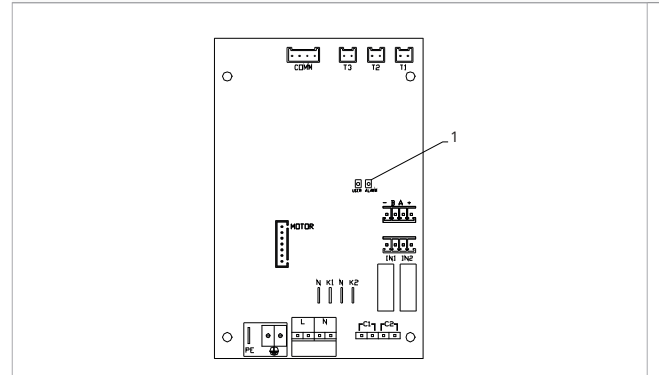
1. LED

⚠ The LED on the cover of the electrical box performs the same functions as the LED on the machine board.

⚠ The flashing LED indicates errors.

⚠ With the LED on and no indication on the display, it is indicated that there are no errors.

LED signals

- ▶ Led flashing
Errors to be shown on the display.
- ▶ LED off
Remote control switched off.
- ▶ LED continuous flashing with pause between flashes
Unsuitable water temperature alarm.
- ▶ LED on
Wall control on and no alarm present.
- ▶ LED 2 flashes / pause
Alarms when the internal fan motor is faulty or disconnected.
- ▶ LED 3 flashes / pause
Alarm for water temperature probe H2/T2 disconnected or faulty.
- ▶ LED 6 flashes / pause
Communication error alarm with wall control panel.

7.6.5 Alarm display on wall control panel



⚠ In the event of an alarm, the device still maintains active functions.

⚠ The symbol  is displayed on the wall control panel to indicate alarms.

⚠ To access the setup menu, it is necessary to access the Basic menu. See section "Basic menu" p. 32.

To visualise errors on the wall control panel

- ▶ press 

Appears .
- ▶ press 

Then the number assigned to the fancoil appears and then the error is displayed.

Displayed alarms

- ▶ E1 Air temperature probe alarm T1 on PUB-30 board disconnected or with incorrect values (-10÷40)

The device is operating and the M7 control uses its own air probe.
- ▶ E2 Internal fan motor faulty or disconnected

None of the modes can be activated.
- ▶ E3 Water temperature sensor H2/T2 disconnected or faulty

None of the modes can be activated.
- ▶ E5 H4/T3 heating water probe disconnected or faulty

None of the modes can be activated.
- ▶ E8 Communication error

Communication error between the wall control panel and the fancoil.
- ▶ bL Key lock

To unlock the display, press  simultaneously for about 3 seconds.
- ▶ h2o Incorrect water temperature

In heating mode, the water temperature is below 30 °C

In cooling mode, the water temperature is above 20 °C.

 Error E8 is displayed without the error display procedure on the wall control panel.

8. WALL-MOUNTED CONTROL COD. PCZ-EFB749

8.1 Interface

1. Display area
2. Keys area

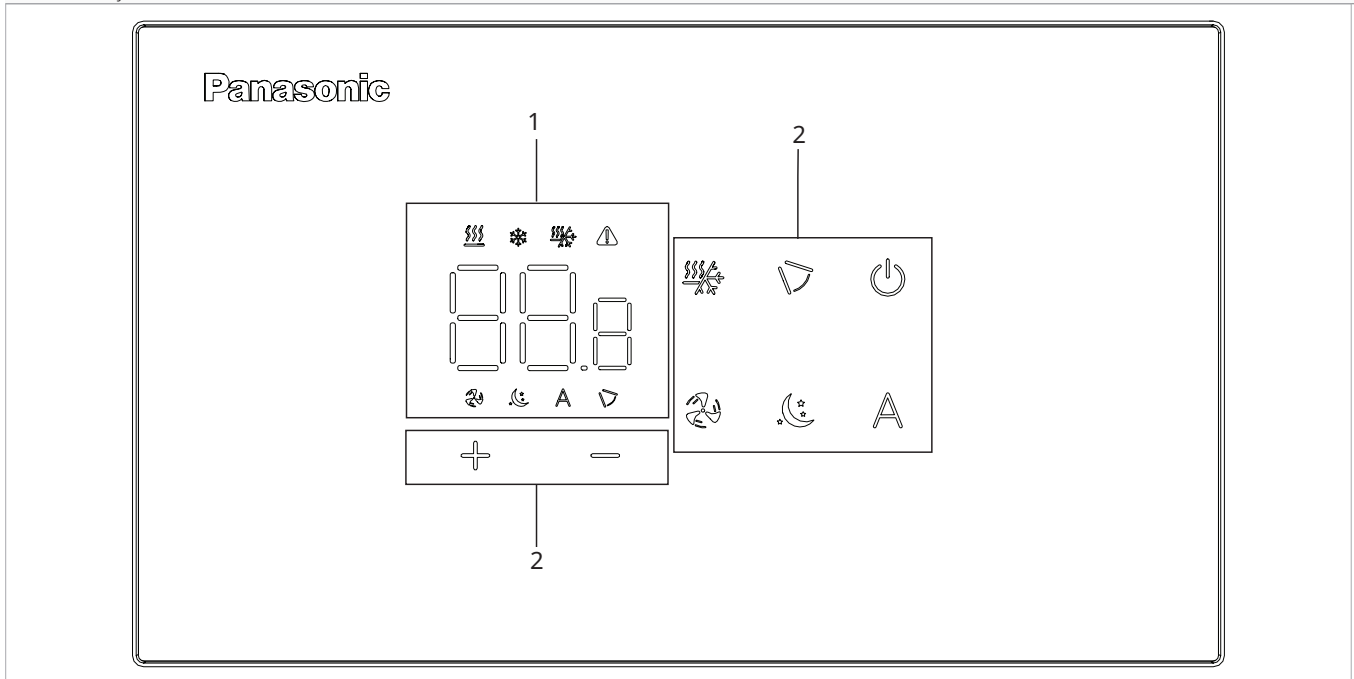

8.2 Installation

8.2.1 Description

The wall-mounted remote control is an electronic LED thermostat with a touch interface, with the possibility of controlling multiple appliances equipped with the same electronic board. It is equipped with a temperature and humidity probe.

- ⚠ The control can manage a maximum of 16 units.
- ⚠ For wall control coding PCZ-EFB749, the Aquarea Home App is available.

8.2.2 Mounting

- ⚠ The control panel must be mounted in an electrical back box.
- ⚠ A wall must be prepared to accommodate the electrical box before installing the wall control.
- ⚠ Ensure that:
 - the wall supports the weight of the appliance
 - the section of the wall does not contain piping or electrical lines

- the functionality of load-bearing elements is not compromised

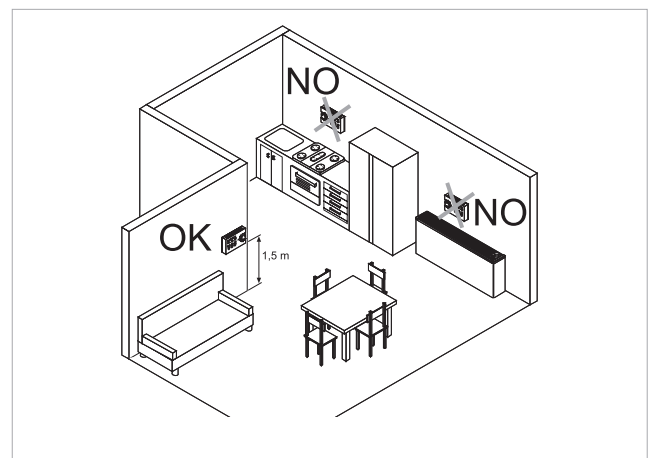

The wall-mounted remote control must be installed:

- on internal walls
- at a height of about 1,5 m from the floor

- ⚠ Should the control be located in an area utilised by persons with reduced physical capabilities, please refer to local regulations.
 - away from doors or windows
 - away from heat sources (heaters, convectors, stoves, direct sunlight)
- ⚠ The wall control is provided inside the package already assembled.

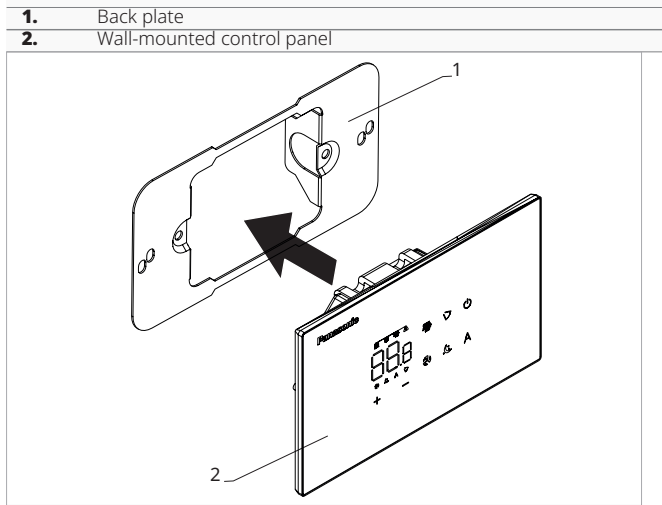

Before wall installation:

- ▶ separate the back plate from the control panel

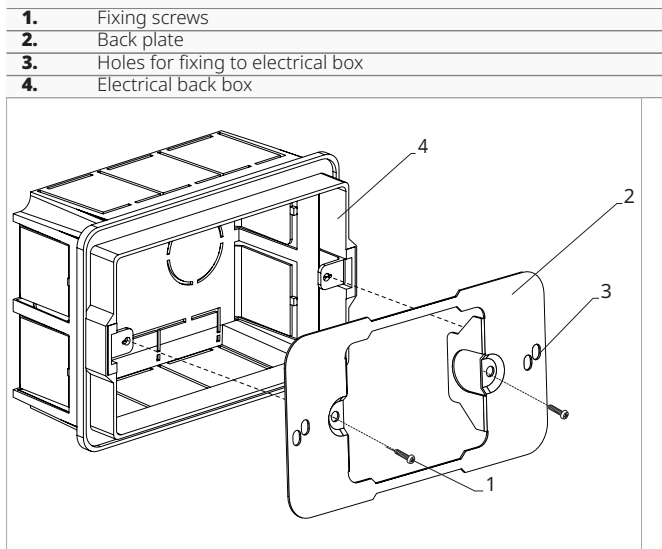

For wall mounting of the control panel:

- ▶ fix the back plate to the electrical back box with screws
- ▶ connect the electrical wiring

- ⚠ Ensure that the air probe sensor is not affected by air currents, whether warm or cold, coming from the recessed wall box.
- ⚠ To avoid interference in temperature measurement:
 - seal the cable-entry conduits tightly so that they do not allow air to pass through.
 - seal any openings in the box or the wall that could connect the back of the thermostat with the air circulating in the wall cavities
- ⚠ proper sealing ensures the correct operation of the sensor and the reliability of thermal regulation

- ⚠ Before making the connections, please verify that the control terminal block is on the right-hand side.
- ⚠ It is mandatory to use ferrules on all conductors, both on the board side and on the wall-mounted terminal block side, to prevent permanent damage to the equipment.
- ⚠ There are multiple holes on the base of the control. The use of the holes depends on the model of the electrical back box used.

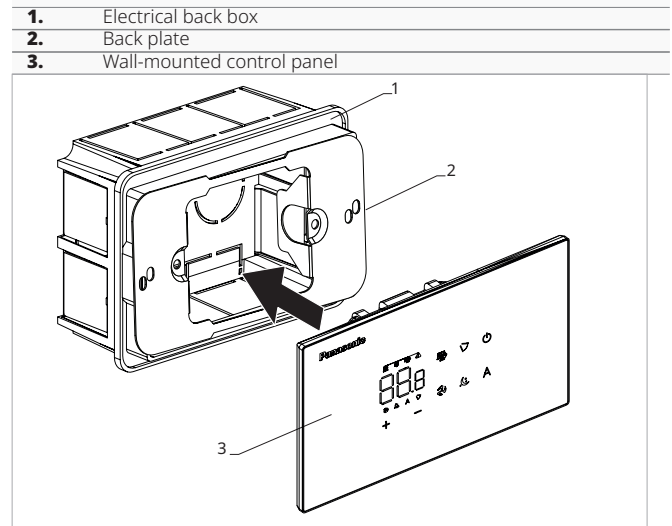

- ▶ Close the control panel

- ⚠ Pay attention not to crush the conductors when you close the control.

8.5 Connections

8.5.1 Preliminary warnings

⚠ The terminals for connecting the control panel and the presence contact CP are placed in a plastic bag and positioned inside the cover of the electrical box.

1. Terminal blocks

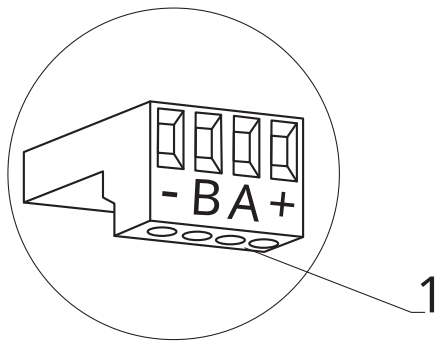

The terminals accept:

- rigid or flexible wires with a 0.2 to 1 mm² cross-section
- rigid or flexible wires with 0,5 mm² cross-section if two wires are connected to the same terminal block
- rigid or flexible wires with 0,75 mm² cross-section if the wires have wire end ferrules with a plastic collar

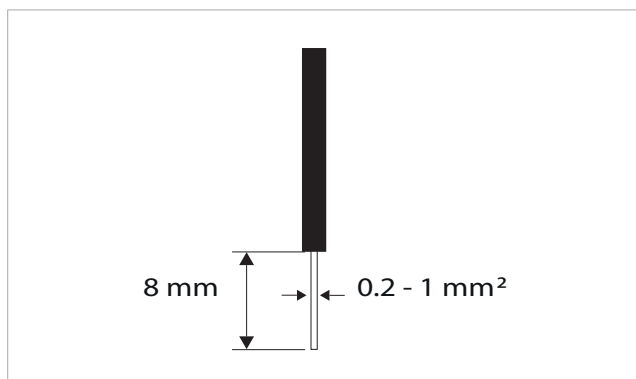

To connect the cables:

- ▶ strip 8 mm of the wire
- ▶ if the wire is rigid, you can insert it easily whereas
- ▶ if it is flexible, use appropriate crimp terminals
- ▶ push the wire in completely
- ▶ check the right fixing by pulling it gently

8.5.2 Control Panel

⚠ The control panel for wall control must be ordered separately.

Terminal block position:

1. Terminal block (Back view panel)

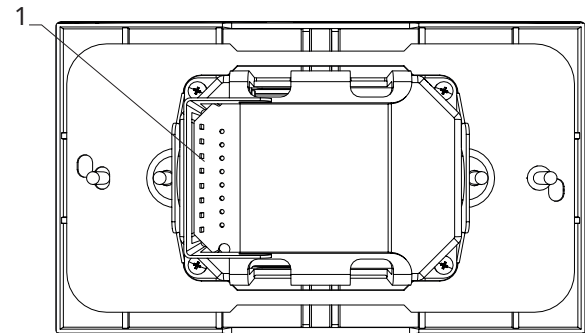

1. Terminal blocks

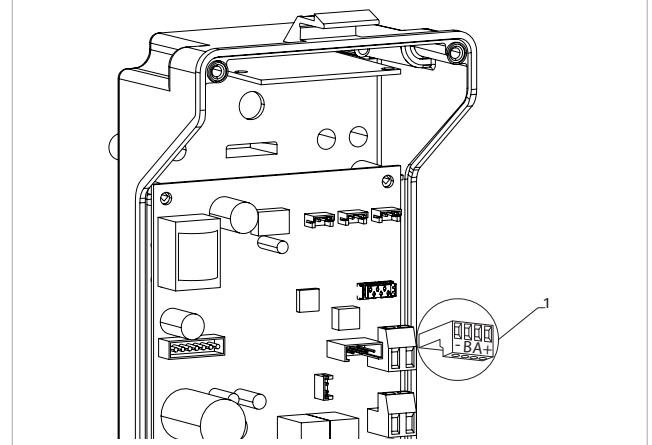

To connect the wall control panel to the board:

- ▶ connect the power supply cables to the + - terminals
- ▶ connect the Modbus serial connection cables to terminals A and B

8.5.3 Presence contact CP

Through this device it is possible to connect an external control signal that inhibits the operation of the control signal, for example:

- opening window contact
- remote on/off
- infrared presence sensor
- activation badge

Function

The contact is normally open (NO).

- ▶ when closing the CP contact, connected to a potential-free contact, the device switches to standby mode

CP appears on the display.

- ▶ At the touch of a button on the display the symbol ⚠ flashes.

⊖ It is forbidden to connect the CP input to that of another unit electronic board. Use separate contacts.

The CP presence contact can be configured for heating and cooling operation via the "To select digital input" p. 44 settings menu item (digital input).

8.5.4 RS485 Serial Connection

The wall-mounted remote control can be connected through an RS485 serial line to one or more devices, up to a maximum of 16.

The devices must be equipped with an electronic board suitable for remote control.

For the connection:

- ▶ follow the indication on the connection diagram
- ▶ connect respecting the polarity indication A and B

⚠ Use a two core cable shielded cable suitable for the RS485 serial connection with a minimum section of 0,35 mm².

⚠ Keep the two core cable separate from power supply cable by a minimum of 50 mm.

⚠ Create a wire path in order to minimize the length of the lead wire.

⚠ Complete the line with the 120 Ω resistor.

⊖ It is forbidden make star connections.

⚠ In the case of a connection between several devices, it is mandatory to carry out the matching between control and device. See section "Pairing of control and unit" p. 44.



8.6 Functions

8.6.1 Basic menu

To access the basic menu



- ▶ with the display off, hold down  for 10 seconds

The device turns on and  appears

- ▶ keep pressed until the indication  appears
- ▶ release the  key

The symbol  appears

To navigate in the menu

- ▶ use the icons  

To select a menu item and to confirm the changes made

- ▶ press the icon 
 - Confirming the change takes you to the next item.*

To exit the menu

- ▶ press the icon  for 10 seconds
- ▶ or wait 30 seconds after the last action
 - The display is switched off automatically.*

⚠ After 30 seconds from the last action the control returns to the start screen and the last chosen values are recorded.

Menu items

ot: AIR probe offset (air probe setting)

ur: Not used

ut: Probe Offset PT4

uS: Humidity setpoint

uI: Humidity hysteresis

CF: Scale

ub: Buzzer volume





uu: Wi-Fi reset

up: Wi-Fi pairing

ho: Hotel Mode

Set AIR probe offset





To set the air probe offset

- ▶ select 
- ▶ press  to change settings
- ▶ increase or decrease the value with the icons  
- ▶ press  to confirm
 - By default it is set to 0.*
 - The setting range is from a minimum of -12.0 °C to a maximum of 12.0 °C.*

Set probe offset RH





⚠ Modify only after real deviations from an actual measurement has been established with professional equipment.

To set the RH probe offset

- ▶ select 
- ▶ press  to change settings
- ▶ increase or decrease the value with the icons  
- ▶ press  to confirm





Set the humidity setpoint

To set the humidity setpoint

- ▶ select 
- ▶ press  to change settings
- ▶ increase or decrease the value with the icons  
- ▶ press  to confirm
 - The setting range is from 20.0% to 90.0%.*



Setting the humidity hysteresis

To set the humidity hysteresis

- ▶ select 
- ▶ press  to change settings
- ▶ increase or decrease the value with the icons  
- ▶ press  to confirm
The setting range is from 1 (min) to 30 (max).





Scale

To change the temperature unit of measure

- ▶ select 
- ▶ press  to change settings
- ▶ select °C or °F
- ▶ press  to confirm
By default the temperature unit of measure is ° C.

Adjusting the volume









To change the volume

- ▶ select 
- ▶ press  to change settings
- ▶ increase or decrease the value with the icons  
- ▶ press  to confirm
The volume setting range is from 00 (min) to 03 (max).

 The volume changes after confirming the modification.









Wi-Fi reset

To reset the Wi-Fi credentials and return the device to its original configuration

- ▶ select 
- ▶ press  to change settings
- ▶ use the   icons in sequence
Appears .
- ▶ press 
 appears to reset Wi-Fi credentials.
- ▶ press  to confirm
Credentials have been reset.

Activate Wi-Fi

To activate Wi-Fi

- ▶ select 
- ▶ press  to change settings
- ▶ use the   icons in sequence
Appears .
- ▶ press 
 appears to enable Wi-Fi pairing.
- ▶ press  to confirm

 The device remains visible on Aquarea Home App for the first 15 minutes after the device is switched on.

Setting the Hotel Mode

To set the Hotel mode

- ▶ select 
- ▶ select YS to turn on Hotel mode
- ▶ select NO to turn off the Hotel mode
By default the device is set to NO.

Activating the Hotel mode:





- the Autochangeover function is deactivated
- the temperature setting range is reduced, in Cooling you can set from 22 °C to 28 °C, in Heating you can set from 16 °C to 24 °C

8.6.2 Advanced Menu



 **To access the setup menu, it is necessary to access the Basic menu. See section "Basic menu" p. 42.**

The special functions menu can be accessed via the control panel.

To access the advanced menu

- ▶ from the basic menu press 
- Appears .*
- ▶ press the  key once
Appears .
- ▶ press  to confirm and log in
The advanced menu is accessed.



To navigate in the menu

- ▶ use the icons  

To select a menu item and to confirm the changes made

- ▶ press  for 2 seconds
Confirming the change takes you to the next item.

To exit the menu

- ▶ press  for about 10 seconds
Appears .
- ▶ press  for about 10 seconds
The display turns off.
- ▶ or wait 30 seconds after the last action
The display is switched off automatically.

Menu items

Ad: Not used

di: Options for digital input

t1: Select air probe M7/PU

rH: Radiant heating options with R20

rC: Radiant cooling options with R20

UC: Not used

Ac: Anti-stratification in cooling



Ah: Anti-stratification in heating

Ed: Not used

Fr: Not used

To select digital input

To change the digital input



- ▶ select 
 - ▶ press  to change settings
 - ▶ select CP for presence contact (default)
 - ▶ select CO to cooling open
 - ▶ select CC to cooling close
 - ▶ press  to confirm
- By default digital input is set to CP.*

⚠ For return to the default settings, set the digital input to "CP".

⚠ By selecting one of the other inputs (CO,CC) the seasonality is locked. It is not possible to modify it through the key  of the control.

Select air probe M7/PU

To select the M7/PU air probe

- ▶ select t1
 - ▶ press  to change settings
 - ▶ select 0 to use air probe M7
 - ▶ select 1 to obtain the values of the T1 probes of the connected PU boards
 - ▶ press  to confirm
- By default, the digital input is set to 0.*

⚠ In the case of paired PU boards, the M7 series control unit takes an average of the probe values.

Set radiant options in heating with R20

⚠ To change the rH function, it is necessary to have the accessory MZS - Single zone module for radiant system.

⚠ To change the settings, please refer to the Instruction Sheet of the accessory MZS - Single zone module for radiant system.







Set radiant options to cooling with R20

⚠ To change the rC function, it is necessary to have the accessory MZS - Single zone module for radiant system.

⚠ To change the settings, please refer to the Instruction Sheet of the accessory MZS - Single zone module for radiant system.

Set the anti-stratification function to cooling







To set the anti-stratification function in cooling mode

- ▶ select 
 - ▶ press  to change settings
- Appears *
- ▶ press  to move within the menu
 - ▶ select  to enable the function
 - ▶ press  to confirm changes
- By default, the anti-stratification function in cooling is set to .*

⚠ The anti-stratification function in cooling is to be set for appliances installed at low floor level equipped with an active air probe.

Set the anti-stratification function in heating mode

To set the anti-stratification function in heating mode

- ▶ select 
 - ▶ press  to change settings
- Appears *
- ▶ press  to move within the menu
 - ▶ select  to enable the function
 - ▶ press  to confirm changes
- By default, the anti-stratification function in heating is set to .*



⚠ The anti-stratification function in heating is to be set for appliances installed high up on the wall or ceiling equipped with an active air sensor.

8.6.3 Pairing of control and unit

⚠ The matching procedure between control and luminaire is mandatory and allows the reception of any alarms.

⚠ In the case of a failed pairing between control and device, and the related appearance of error E8, after 10 minutes, the control enables broadcast communication. The E8 error is then eliminated and the control sends signals to all devices without receiving any feedback.

To pair the control with the unit

- ▶ with control switched on, at the same time press  and  for about 10 seconds
- In the display area, where the setpoint is indicated, appears the number of connected devices.*

The displayed value flashes.

1. Red LED
2. Green LED
3. Black button
4. Electrical back box

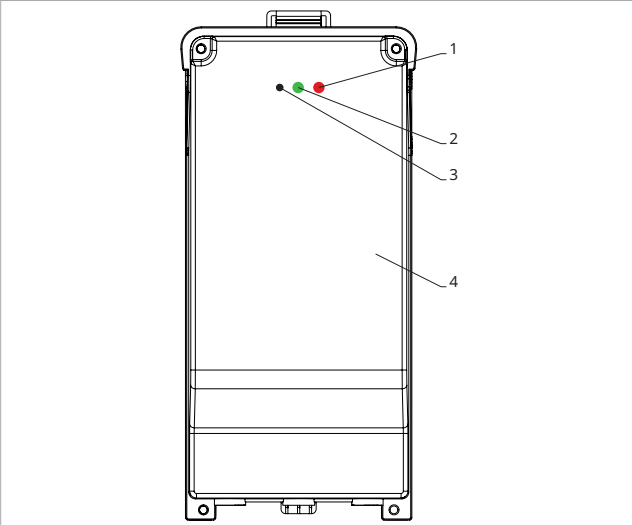

On the electrical box on the unit

- ▶ press the black button for 3 seconds
The green LED flashes.
The red LED is on.
- ▶ wait for the procedure to complete
The green LED stops flashing.

On the wall mounted control panel

- ▶ *Appear the number assigned to the fancoil.*
Then appears the number of connected devices.
- ▶ press to exit the menu

⚠ **To reset the pairing settings, it is first necessary to access the basic menu. See section "Basic menu" p. 42.**

To reset pairing settings

- ▶ access the basic menu
- ▶ press
- ▶ press
- ▶ *All the way to the menu.*
- ▶ press

To reset a single fancoil

- ▶ *Appears .*
- ▶ press
- ▶ *Appears .*
- ▶ press to log in
- ▶ use the icons to move inside the menu
The assignment numbers assigned to the fancoils appears.
- ▶ select the fancoil to be reset
- ▶ press to confirm
-- appears, with an acoustic signal.
The device is removed.

To exit the setting

- ▶ press for 5 seconds
Exit the setting.
Back to menu 02.

To reset all fancoils

Appears .

- ▶ press until appears
Appears .
- ▶ press to confirm
- ▶ use the icons to move inside the menu
- ▶ select No to maintain all fancoils
- ▶ select Yes to reset the fancoils
- ▶ press to confirm

LED interface operation on the electrical box

If the device is being paired

The green LED flashes.

If the device is paired and functioning

The green LED is on.

If the device has not been paired and is not functional

The green LED is off.
The red LED is on.

If the device is in alarm status

The red LED flashes.

⚠ The red LED flashes according to the type of alarm. To check the alarm type, please refer to the following "Error signals" p. 45 section.

If communication with the board is missing

The green and red LEDs will flash once every second.

8.6.4 Error signals

The PCB has a status LED.

1. LED

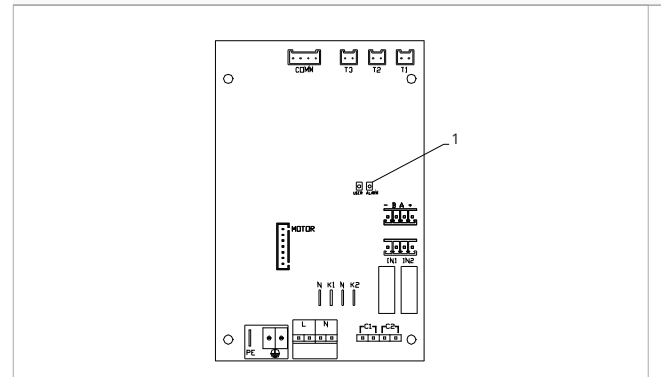

⚠ The LED on the cover of the electrical box performs the same functions as the LED on the machine board.

⚠ The flashing LED indicates errors.

⚠ With the LED on and no indication on the display, it is indicated that there are no errors.

LED signals

- ▶ Led flashing
Errors to be shown on the display.
- ▶ LED off
Remote control switched off.
- ▶ LED continuous flashing with pause between flashes
Unsuitable water temperature alarm.

- ▶ LED on
Wall control on and no alarm present.
- ▶ LED 2 flashes / pause
Alarms when the internal fan motor is faulty or disconnected.
- ▶ LED 3 flashes / pause
Alarm for water temperature probe H2/T2 disconnected or faulty.
- ▶ LED 6 flashes / pause
Communication error alarm with wall control panel.



8.6.5 Alarm display on wall control panel

⚠ In the event of an alarm, the device still maintains active functions.

⚠ The symbol  is displayed on the wall control panel to indicate alarms.

⚠ **To access the setup menu, it is necessary to access the Basic menu. See section "Basic menu" p. 42.**

To visualise errors on the wall control panel

- ▶ press 
Appears .
- ▶ press 
Then the number assigned to the fancoil appears and then the error is displayed.

Displayed alarms

- ▶ E1 Air temperature probe alarm T1 on PUB-30 board disconnected or with incorrect values (-10÷40)
The device is operating and the M7 control uses its own air probe.
- ▶ E2 Internal fan motor faulty or disconnected
None of the modes can be activated.
- ▶ E3 Water temperature sensor H2/T2 disconnected or faulty
None of the modes can be activated.
- ▶ E5 H4/T3 heating water probe disconnected or faulty
None of the modes can be activated.
- ▶ E8 Communication error
Communication error between the wall control panel and the fancoil.
- ▶ bL Key lock
To unlock the display, press  ⇐ simultaneously for about 3 seconds.
- ▶ h2o Incorrect water temperature
*In heating mode, the water temperature is below 30 °C
In cooling mode, the water temperature is above 20 °C.*

⚠ Error E8 is displayed without the error display procedure on the wall control panel.

9. CONNECTION 0-10 V CODE PCZ-B10842

9.1 Installation

9.1.1 Description

On-board electronic printed circuit board for control from systems with 0-10 V analogue output. Mounted on the unit, it allows the motor to be managed with modulating speed.

Motor regulation can be made through a 0-10 V analogue input with an input impedance of 25 kΩ.

⚠ Consider the impedance value, especially when controlling several units in parallel.

It has a 230 V output for controlling a solenoid valve.

9.2 Connection diagram

M1	DC fan motor
	Earth connection
230~50	Power supply connection 230 V / 50 Hz / 1 A

Y1	Water solenoid valve (230 V / 50 Hz / 1 A power output)
10V	Input 0-10 V
F10	Electronic board on the machine

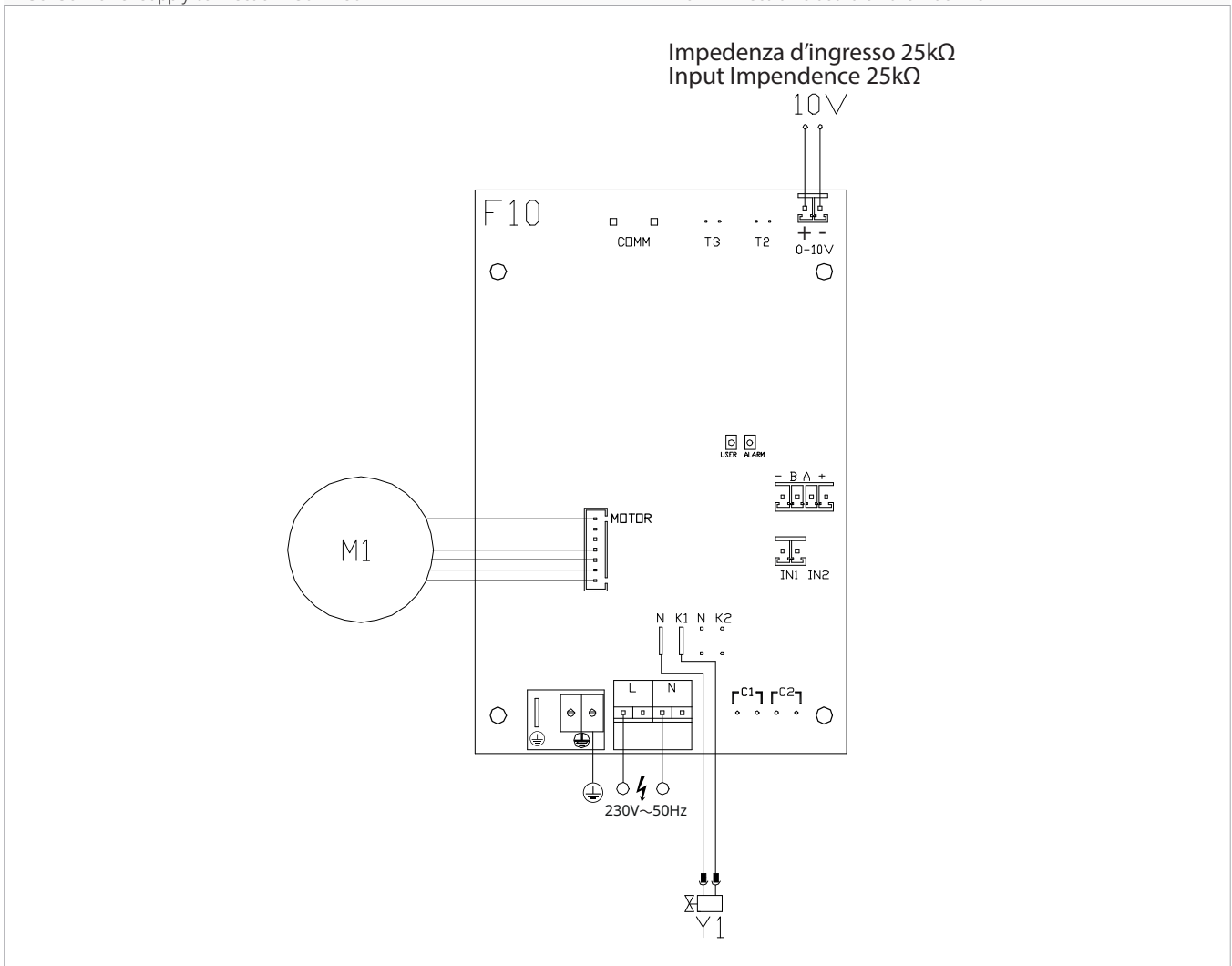

9.3 Connections with 0-10 V thermostats

The 10 V input

- activates solenoid valve Y1
- regulates the fan speed

Linear speed regulation is possible, from a minimum value (400 rpm) to a maximum value (1500 rpm) for voltage values ≥ 1.1 V to 10 V DC.

- ⚠ The motor is switched off for values below 1 V.
- ⚠ The Y1 solenoid valve is switched on for voltage values greater than 1 V. The Y1 solenoid valve is switched off at values below 0.9 V.

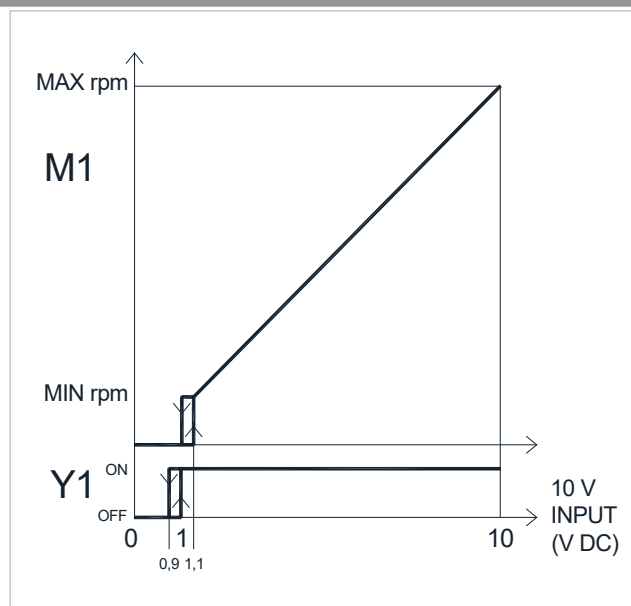

9.4 LED signal

The PCB has a status LED.

LED signals

- ▶ LED off
Input signal below 0.9 V. Device switched off or without power supply.
- ▶ LED on
Input signal more than 1 V. Normal operation of the device.
- ▶ LED frequent flashing
Activation of grille safety microswitch S1, due to the filter cleaning operation.
- ▶ LED 2 flashes / pause
Motor alarm (for example jamming due to foreign bodies or fault in the rotation sensor).

10. TECHNICAL INFORMATION

10.1 Operating limits

Limits of operation of the control

	u.d.m.	Heating	Cooling
Minimum room relative humidity	%	15	15
Maximum room relative humidity	%	80	80
Minimum room air temperature	°C	-10	-10
Maximum room air temperature	°C	50	50

Panasonic[®]

Panasonic Corporation
1006 Kadoma, Kadoma City, Osaka, Japan